



MSA Corporate Headquarters: P.O.Box 426, Pittsburgh, PA 15230, USA
USA Ph: 1-800-672-2222 Fax: 1-800-967-0398 Canada Ph: 1-800-672-2222
• Web Site: www.msanet.com • e-mail: rose@msanet.com

MSA Rail Slider™ Anchorage Connector P/N# 10030608

Application, Operation, Maintenance & Inspection Instruction Manual

***Please read this manual.
This information is vital to your safety.***

Application

The MSA Rail Slider™ Device is an anchorage connector. When attached to an approved anchorage (rail) provides fall protection during horizontal movement. Applications include railway bridges and overhead bridge cranes.

WARNING

THESE INSTRUCTIONS MUST BE PROVIDED TO THE USER. MANAGEMENT AND USER MUST READ AND UNDERSTAND THESE INSTRUCTIONS; FAILURE TO DO SO COULD RESULT IN SERIOUS INJURY OR DEATH.

Copyright © 2001 MSA

All rights reserved. No part of this Catalogue covered by the copyrights hereon may be reproduced or copied in any form or by any means - graphics, electronic or mechanical, including photocopying, recording, taping or information storage and retrieval systems -without the written permission of MSA .

Function

The MSA Rail Slider™ device is easily and quickly installed anywhere along an approved anchorage (rail). The slider will move along the rail, pulled by the workers lanyard/harness. No unhooking and re-hooking of the lanyard is required when changing work locations. The Rail Slider™ device comprises of a pair of rail profile plates, which interlock via a set of receiving bolts. A lanyard is attached to an approved carabiner securing the profile plates to the crown of the rail.

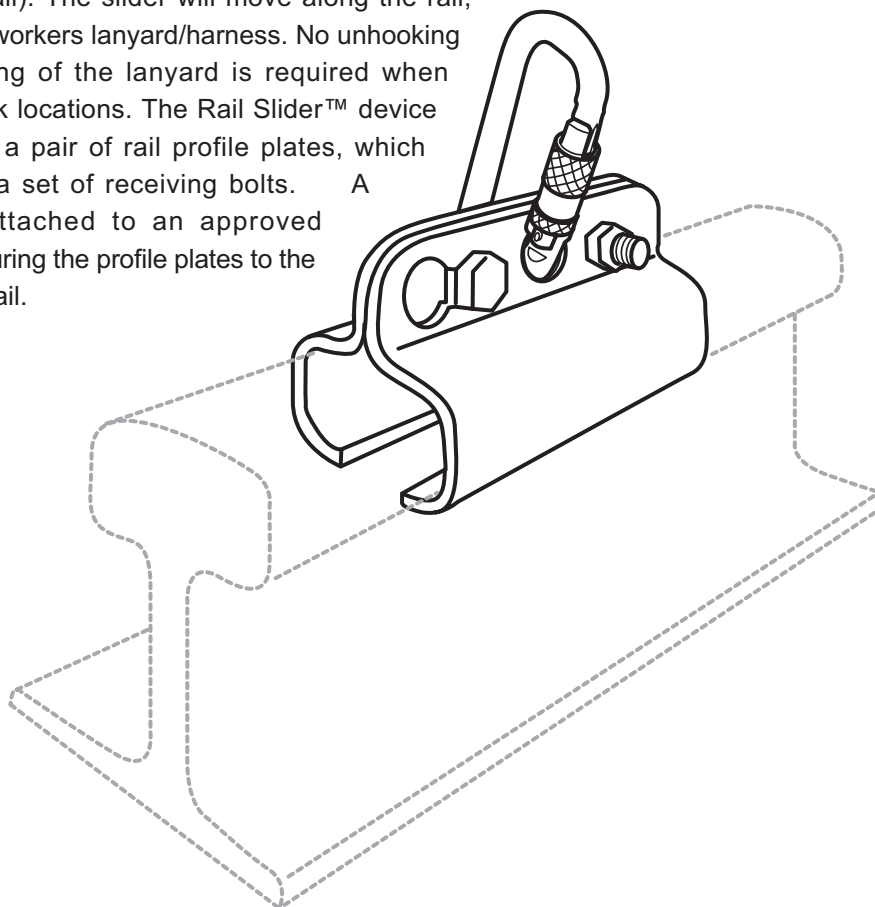

ONE PERSON: Design working load is 310 lbs (140kg) /person for individual use on an approved anchorage (rail).

Specifications

P/N#: 10030608

MATERIAL: SA516 Grade 70 Steel

FINISH: Yellow Zinc Plated

SUPPORT STRENGTH: Greater Than 6,750 lbs (30kN)

SIZE APPROX: 7" x 4" x 4" (18cm x 10cm x 10cm)

WEIGHT APPROX: 6 lbs (2.7kg)

Operating Instructions



1. Follow Rail Slider™ design statements prior to following operating instructions.
2. No tools are required.
3. Place a Rail Slider™ profile plate on the crown of the rail section. Note: Ensure rail section is 90 lbs/yd minimum and 141 lbs/yd maximum.



CAUTION: Make certain rail head is not worn beyond proper fit limits, as stated, along the entire length of the rail on which the Rail Slider™ is to be used. Rail worn beyond fit limits will result in inadequate fall arrest protection as designed.

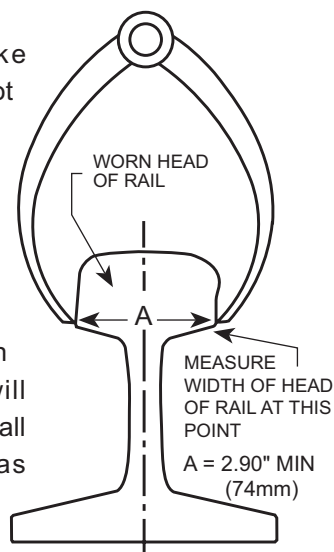

DO NOT USE ON "HEAD-FREE" RAIL.



Check width of rail head. Width at bottom of rail head (Dimension "A") must be greater than or equal to 2.90" (74mm). If "A" is less than 2.90" (74mm) **DO NOT USE RAIL SLIDER™.**

4. Align the second Rail Slider™ profile plate with the first plate. Permit passage of the receiving bolts, the top flat section of the profile plates shall be flush with each other.

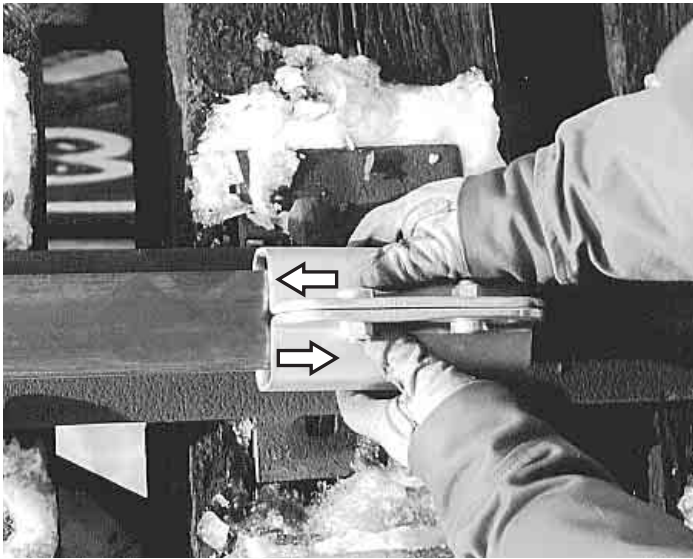

- Once the profile plates are flush with each other, slide each plate in opposite directions parallel to the rail. The plates are now locked on the crown of the rail.



CAUTION: Check for proper fit along the entire length of the rail the device is to be used on.



- Attach an approved carabiner (Autolock) into the attachment hole. The recommended carabiner for use with the Rail Slider™ is RCC643, an acceptable substitute is RCC613. Once the carabiner is locked in place the profile plates are now locked and secure.



- Attach an approved lanyard/harness to the carabiner. Ensure hardware is compatible. **ONLY USE APPROVED HARDWARE.**
- The MSA Rail Slider™ is now functional.
- To remove the Rail Slider™ from the rail, follow Operating Instructions in reverse.

1. Equipment shall be inspected by the user before each use, and additionally, by a competent person other than the user at intervals of no more than one year. Detailed inspections must be recorded in the inspection log.
2. When inspection reveals defects, damage, or inadequate maintenance, the device shall be permanently removed from service to undergo adequate corrective maintenance before return to service.
3. Remove device from service immediately if
 - subjected to the forces of arresting a fall;
 - labels are missing or illegible;
 - absence of any elements affecting the device form, fit or function;
 - there is evidence of defects in or damage to hardware elements including cracks, sharp edges, deformation, severe corrosion, alteration or excessive wear;
 - hardware parts are absent or the device fails to function properly.

NOTE: OPENING TO BE MEASURED AT EACH END WITH APPLICATION OF NOMINAL SPREADING FORCE OF THE HAND

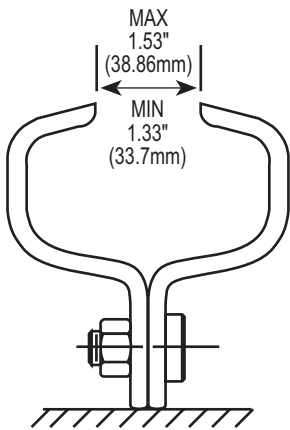

CHECK WIDTH OPENING OF RAIL SLIDER™. THE DISTANCE BETWEEN THE TIPS MUST BE LESS THAN OR EQUAL TO 1.53" (38.86mm)

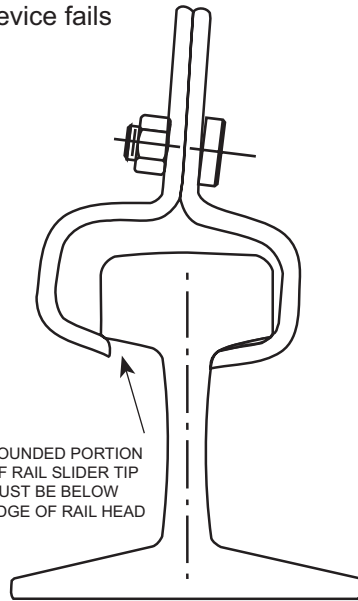

ENSURE THAT BOTTOM TIP OF RAIL SLIDER™ WILL BE BELOW THE SIDE OF THE RAIL HEAD. THE TIP SHOULD NOT BE ADJACENT TO THE SIDE OF THE HEAD OF THE RAIL WHEN THE SLIDER IS LIFTED AS SHOWN.

MINIMUM MATERIAL THICKNESS: 3/16" (5mm)

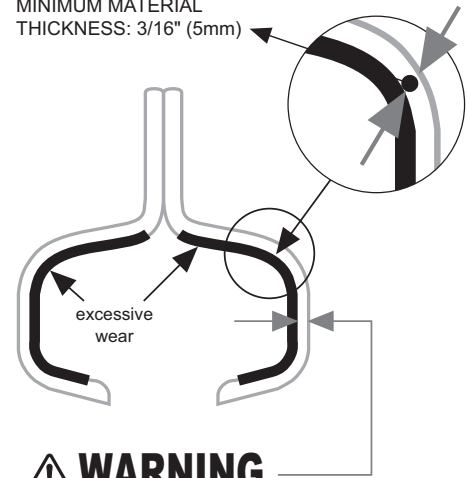

⚠ WARNING

MINIMUM MATERIAL THICKNESS: 3/16" (5mm)
REMOVE DEVICE FROM SERVICE IF MATERIAL THICKNESS IS LESS THAN 3/16" (5mm)

⚠ Rail head wear should be checked along the entire length of use area.

4. MSA or persons or entities authorized in writing by the manufacturer, shall make repairs to the equipment. No unauthorized repairs and/or modifications are allowed.
5. Both halves of the Rail Slider™ are marked with a distinct serial number. When inspecting, ensure both halves have the same serial number.

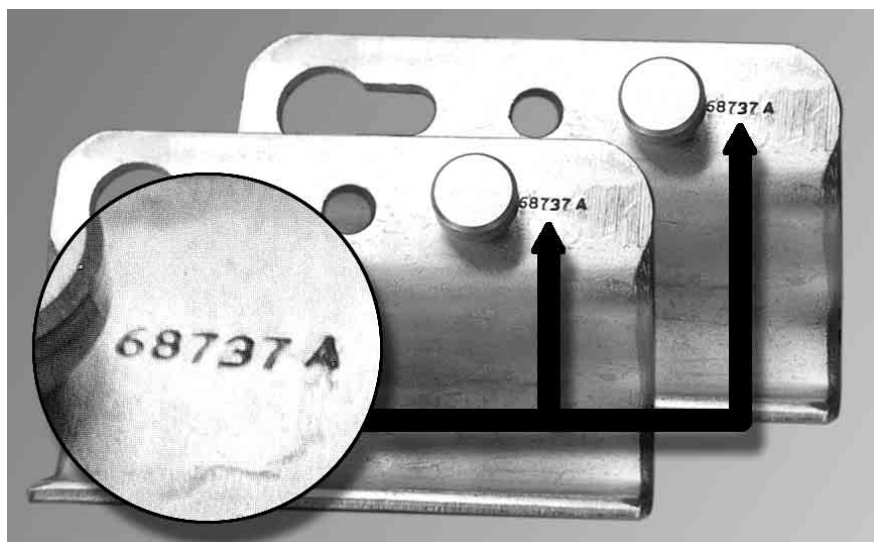

1. Maintenance and storage of equipment shall be conducted by the user's organization in accordance with MSA instructions. Unique issues, which may arise due to conditions of use, shall be addressed with MSA.
2. Devices which are in need of or scheduled for maintenance shall be tagged as "unusable" and removed from service.
3. To clean use a mild soap. Wipe device dry after cleaning.
4. Device should be lubricated with a light oil to ensure good working order.
5. Store in a clean, dry area free from excessive heat, steam, harmful fumes and corrosive agents.
6. When in doubt of the operation, maintenance and inspection procedures, DO NOT USE.

Design Statements

1. The MSA Rail Slider™ anchorage connector shall comply with government and/or other applicable regulations and standards.
2. An approved anchorage rail shall be secured and capable of supporting 5,000 lbs (22kN) per user.
3. The MSA Rail Slider™ is approved for use on 90-141 lbs/yd rail sections.



CAUTION: Worn rail head profile will cause the Rail Slider™ to come loose from the rail and not provide fall arrest protection.



4. Only one (1) person shall use the MSA Surety Rail Slider™ at one time.
5. Lanyard length shall be kept as short as possible, and in accordance with federal and local fall distance regulations.
6. A Sure-Stop™ shock absorber attached to full body harness is mandatory in the fall arrest system.
7. The approved MSA connector (hardware) for the Rail Slider™ is MSA Carabiner P/N RCC643 or RCC613. No other connector hardware shall be used unless authorized by MSA.
8. Remove MSA Rail Slider™/Fall Arrest System from service immediately if the system has arrested a fall.



WARNING: Remove device from service if material thickness is less than 3/16" (5mm).



CAUTION: Do not use on rail that is worn beyond fit limits or is of improper size.

10. All potential users of this equipment and users management must read and understand the instructions fully; failure to do so could result in serious injury or death.
11.  **HAZARD WARNING:** If an open end exists on the rail and which allows the Rail Slider™ to slide off, precautions should be taken to prevent the slider from sliding off the rail exposing the user to a fall hazard.
12. All equipment should be used as part of a complete, comprehensive engineered fall protection system. No unauthorized manufacturers equipment should be used in the system without written approval by MSA. If the buyer chooses to disregard this warning he assumes sole responsibility for the integrity of the entire system.
13.  **HAZARD WARNING:** Do not install Rail Slider™ where there exists the possibility of the device coming into contact with equipment running on the same common rail.

IF IN DOUBT, PLEASE CONSULT MSA.

Serial Number _____

Model Number _____

Date Purchased _____

Inspection Date	Inspection Items Noted	Corrective Action Taken	Maintenance Performed
Approved by _____			
Approved by _____			
Approved by _____			
Approved by _____			
Approved by _____			
Approved by _____			
Approved by _____			

Distributed by:

WARRANTY

Express Warranty – MSA warrants that the product furnished is free from mechanical defects or faulty workmanship for a period of one (1) year from first use or eighteen (18) months from date of shipment, whichever occurs first, provided it is maintained and used in accordance with MSA's instructions and/or recommendations. Replacement parts and repairs are warranted for ninety (90) days from the date of repair of the product or sale of the replacement part, whichever occurs first. MSA shall be released from all obligations under this warranty in the event repairs or modifications are made by persons other than its own authorized service personnel or if the warranty claim results from misuse of the product. No agent, employee or representative of MSA may bind MSA to any affirmation, representation or modification of the warranty concerning the goods sold under this contract. MSA makes no warranty concerning components or accessories not manufactured by MSA, but will pass on to the Purchaser all warranties of manufacturers of such components. THIS WARRANTY IS IN LIEU OF ALL OTHER WARRANTIES, EXPRESS, IMPLIED OR STATUTORY, AND IS STRICTLY LIMITED TO THE TERMS HEREOF. MSA SPECIFICALLY DISCLAIMS ANY WARRANTY OF MERCHANTABILITY OR FITNESS FOR A PARTICULAR PURPOSE.

Exclusive Remedy - It is expressly agreed that the Purchaser's sole and exclusive remedy for breach of the above warranty, for any tortious conduct of MSA, or for any other cause of action, shall be the repair and/or replacement, at MSA's option, of any equipment or parts thereof, that after examination by MSA are proven to be defective. Replacement equipment and/or parts will be provided at no cost to the Purchaser, F.O.B. Purchaser's named place of destination. Failure of MSA to successfully repair any nonconforming product shall not cause the remedy established hereby to fail of its essential purpose.

Exclusion of Consequential Damages - Purchaser specifically understands and agrees that under no circumstances will MSA be liable to Purchaser for economic, special, incidental, or consequential damages or losses of any kind whatsoever, including but not limited to, loss of anticipated profits and any other loss caused by reason of the non-operation of the goods. This exclusion is applicable to claims for breach of warranty, tortious conduct or any other cause of action against MSA.

For additional information, please contact the Customer Service Department at 1-800-MSA-2222 (1-800-672-2222).