

# MSA Miner's Belt

## User Instructions

 **WARNING**

*National standards and state, provincial and federal laws require the user to be trained before using this product. Use this manual as part of a user safety training program that is appropriate for the user's occupation. These instructions must be provided to users before use of the product and retained for ready reference by the user. The user must read, understand (or have explained), and heed all instructions, labels, markings and warnings supplied with this product and with those products intended for use in association with it. FAILURE TO DO SO MAY RESULT IN SERIOUS INJURY OR DEATH.*

### 1.0 MODELS & SPECIFICATIONS

#### 1.1 MODELS

Miner's belts made by Rose Manufacturing Company are available with two styles of buckles. The models are:

- Friction Buckle, Nylon (Yellow) Without Body Pad - P/N 502620
- Friction Buckle, Nylon (Yellow) With Body Pad- P/N 502625
- Tongue Buckle, Nylon (Yellow) Without Body Pad - P/N 502060 AND 502095
- Tongue Buckle, Nylon (Flame) Without Body Pad- P/N 507078

#### 1.2 SPECIFICATIONS (SEE FIGURE 1)

- |  |                                   |  |
|--|-----------------------------------|--|
| 1. Friction Buckle (Friction Buckle Belts) | 7. Respirator Pack (Not Supplied) | 13. Belt Tongue (Friction Buckle Belt)                             |
| 2. Tongue Buckle (Tongue Buckle Belts)     | 8. D-ring                         | 14. Belt Tongue (Tongue Buckle Belt)                               |
| 3. Keeper                                  | 9. Read & Heed Label              | 15. General Instructions   |
| 4. Respirator Pack Strap & Buckle          | 10. Battery Pack Strap & Buckle   | 16. Safety Line or Lanyard w/Double Locking Saphook (Not Supplied) |
| 5. I. D. & Inspection Tag                  | 11. Battery Pack (Not Supplied)   | 17. Caution Label (D-ring)   |
| 6. Strap Loop                              | 12. Body Pad                      |  |

### 2.0 TRAINING

It is the responsibility of the purchaser of the MSA Miner's Belt to assure that product users are made familiar with these user instructions and trained by a competent person. Training must be conducted without undue exposure of the trainee to hazards. MSA offers training programs, please contact for training information.

### 3.0 DESCRIPTION

The MSA Miner's Belt is a utility belt designed to carry emergency equipment. The Miner's Belt is also fitted with a metal D-ring for connecting a safety line or lanyard for restraint to prevent the user from reaching a hazard zone. The load-bearing portion of the belt is constructed of nylon webbing, 1 3/4 inches (44 mm) wide. Some versions of the Miner's Belt include a nylon body pad sewn to the inside of the belt. The miner's belt may be equipped with either a metallic tongue buckle or friction buckle clasp.

### 4.0 SELECTION AND APPLICATIONS

#### 4.1 PURPOSE OF MINER'S BELT

The Miner's Belt is designed to be used for restraint, not for fall arrest. It is also intended as a means for carrying a miner's battery pack and emergency respirator pack.

For More Information, call 1-800-MSA-2222 or Visit Our Website at [www.MSAnet.com](http://www.MSAnet.com)



**MINE SAFETY APPLIANCES COMPANY**  
**PITTSBURGH, PENNSYLVANIA, U.S.A. 15230**

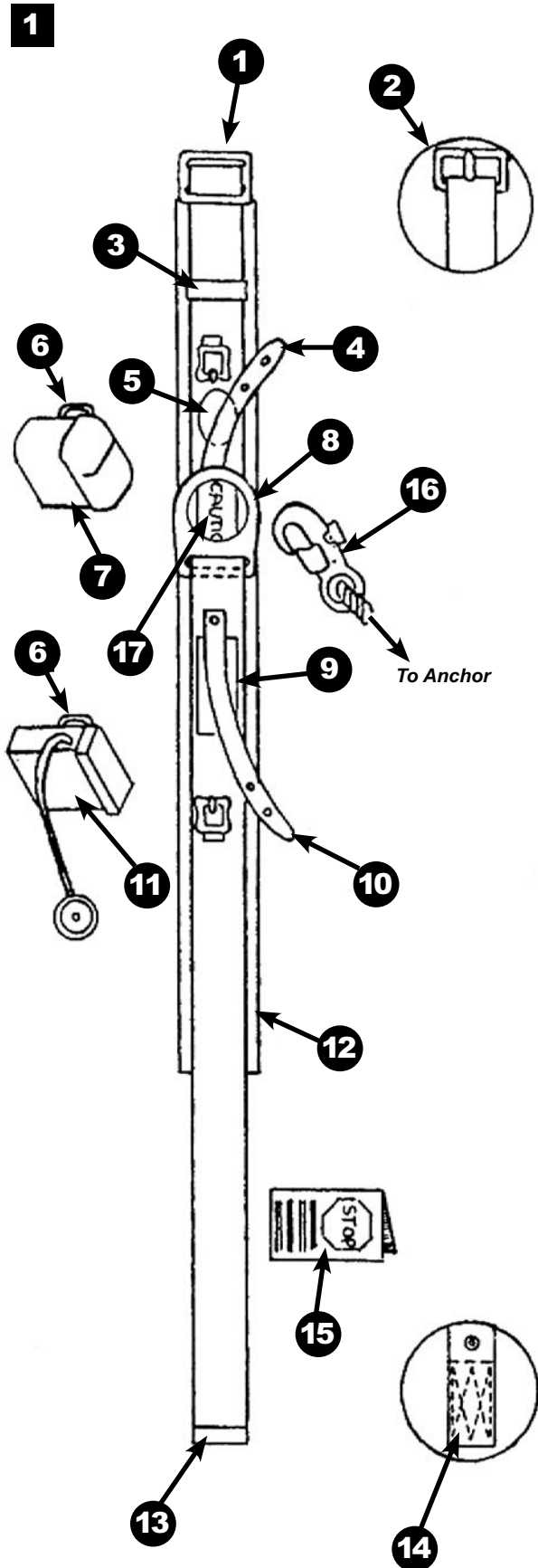

## 4.2 USAGE LIMITATIONS

Use only for restraint. Use a full body harness for fall arrest. Be sure the Miner's Belt is fitted properly for your waist size.

Chemical hazards, heat and corrosion may damage the Miner's Belt. More frequent inspections are required in these environments. Do not use in environments with temperatures greater than 185° F (85° F). Use caution when working around electrical hazards, moving machinery and abrasive surfaces.

## 5.0 SYSTEM REQUIREMENTS

Use as part of a complete system for restraint, including a compatible restraint lanyard and restraint anchor. The restraint system must prevent the worker from reaching a fall hazard.

### 5.1 COMPATIBILITY OF SYSTEM PARTS

#### 5.1.1 COMPATIBILITY OF CONNECTORS

Use the MSA Miner's Belt with compatible MSA self-closing, self-locking snaphooks and carabiners only. Connect only to the D-ring of the belt, located at the back. Connecting hardware must be compatible in size, shape and strength. Non-compatible connectors may accidentally disengage ("roll-out"). Always verify that the connecting snaphooks or carabiners are closed and locked before use.

#### 5.1.2 ANCHORAGES AND ANCHORAGE CONNECTORS

Anchorage and anchorage connectors for restraint must have a strength capable of supporting a static load, applied in the directions permitted by the system, of at least two times the weight of the worker attached.

## 6.0 PLANNING THE USE OF SYSTEMS

### 6.1 RESTRAINT SYSTEM REQUIREMENTS

The fall restraint system must prevent the worker from reaching a fall hazard by restricting movement to within 6 feet (1.8 m) of an exposed edge or unguarded opening.

Use a full body harness with shock absorbing lanyard connected to a suitable fall arrest anchor whenever working within reach of a fall hazard.

### 6.2 RESCUE AND EVACUATION

The user must have a rescue plan and the means at hand to implement it. The plan must take into account the equipment and special training necessary to effect prompt rescue under all foreseeable conditions.

## 7.0 USAGE

### 7.1 INSPECT BEFORE EACH USE

Inspect the Miner's Belt to verify that it is in serviceable condition. See the section on inspection for details. Do not use if inspection reveals an unsafe condition.

### 7.2 USE OF BELT

Current US Mine Safety and Health Administration (MSHA) rules permit the use of belts in fall arrest (reference 30 CFR 56/57.1005, "Safety Belts and Safety Lines"). Current US Federal Occupational Health and Safety Administration (OSHA) rules prohibit the use of belts in fall arrest (reference 29 CFR 1926.502). MSA advises against the use of belts in fall arrest regardless of application.

For additional guidance in the use of personal protection equipment, contact your safety director.

### 7.3 ATTACHING RESPIRATOR AND BATTERY PACK TO BELT

Before buckling belt about hips, attach respirator and battery pack by means of straps and buckles shown in illustration, Figure 1. The packs have strap loops for connection to belt. These strap loops must be next to belt when straps are threaded through the loops. The bulk of each pack should hang below the belt. To ease buckling and unbuckling of pack straps, flex belt webbing behind straps. Cinch pack straps to tightest notch to minimize flopping of pack. Always thread pack strap through the second side of buckle.



**CAUTION**

*Do not attach objects other than respirator pack and battery pack to pack straps.*

## 7.4 CONNECTING SAFETY LINE (LANYARD) TO D-RING

Use D-ring only for connecting to a fall restraint lanyard.



### CAUTION

**Connect only locking snaphook or carabiner with gate size of 3/4 inch (20 mm) or smaller to the D-ring.**

Use a restraint lanyard with an MSA double-locking snaphook or carabiner. Do not rely on the feel or sound of the connector to ensure proper connection, always check to verify connector is closed and locked. Do not permit foreign objects (such as battery pack cord) to interfere with connection of snaphook to D-ring. Position the D-ring in the middle of the back at hip height.

## 8.0 CARE, MAINTENANCE AND STORAGE

### 8.1 CLEANING INSTRUCTIONS

Clean the Miner's Belt with a damp cloth and wipe dry. Excessive accumulation of dirt, paint or other foreign matter may prevent proper function of the device. Questions concerning the condition of your Miner's Belt, or if any question arises about putting the equipment into service, consult a qualified safety engineer or contact MSA.

### 8.2 MAINTENANCE AND SERVICE

There are no field serviceable elements in the Miner's Belt. Do not attempt field repairs. Equipment which is damaged should be tagged as "UNUSABLE" until destroyed.

### 8.3 STORAGE

Store the Miner's Belt in a clean, dry place. Avoid areas where moisture, heat, oil and chemicals or their vapors or other degrading conditions may be present. Equipment which is damaged should not be stored in the same area as useable equipment. Heavily soiled, wet or otherwise contaminated equipment should be properly maintained (e.g. cleaned and dried) prior to storage. Prior to using equipment which has been in storage for long periods of time, a Formal Inspection should be performed by a competent person.

## 9.0 MARKINGS AND LABELS

The following labels shown must be present and legible.

## 10.0 INSPECTION

### 10.1 INSPECTION FREQUENCY

The Miner's Belt must be inspected by the user before each use and, additionally, by a competent person other than the user at intervals of no more than 6 months. The competent person inspection is referred to as a Formal Inspection and includes documentation of the inspection on a Formal Inspection Log.



### CAUTION!

**The frequency of inspection by a competent person shall be established by the user's organization within the limits stated above, and based on such factors as the nature and severity of the workplace conditions, modes of use and exposure time of the equipment.**

### 10.2 INSPECTION STEPS

- Step 1:** Conduct a complete visual and tactile inspection of the device. Clean if necessary before inspection. Inspect both sides of the belt.
- Step 2:** Inspect visually for evidence of alteration. Refer to the Miner's Belt Inspection Diagram and verify each element is present and has not been tampered with.
- Step 3:** Inspect metallic elements, including buckles, D-ring, rivets and grommets (if present). Inspect by visual and tactile means for any missing or broken pieces, cracks, breaks, sharp edges, and bent or deformed areas. Inspect for visible signs of corrosion, evident as pitting or scaling on the metal surface.
- Step 4:** Inspect fiber webbing and stitching by visual and tactile means. Inspect for tears, cuts, frayed thread, missing or broken stitches, and evidence of chemical attack or high heat exposure. Damage from heat is usually noticeable as a darkened or fused area of fiber.
- Step 5:** Record the inspection date, identity of the competent person inspector and the inspection results. Refer to the Formal Inspection Log in these instructions.

**MSA**

MODEL: MODEL  
SIZE: SIZE  
MEETS: MEETS  
DATE: DATE

**CAUTION**

Do not use single locking snaphook on this D-ring. Use D-ring as stated in manufacturer's User Instruction.

706 REV. 5

620703

**WARNING - READ AND HEED!**

Before use, read the manufacturer's instructions furnished with this product. If unavailable, contact MSA Customer Service at 1-800-672-2222 for the instructions. The proper application of this product must be determined before use. When a fall hazard exists, the fall-arresting D-Ring should be located behind the user's hips. When attaching another device to this product, be certain the device is appropriate and is properly attached. Before use, inspect all equipment carefully and replace, if excessive wear or damage is apparent. If any equipment is subjected to impact loading, remove from service immediately.

**- Do Not Remove This Label -**

**MSA** MINE SAFETY APPLIANCES COMPANY  
PITTSBURGH, PENNSYLVANIA, U.S.A. 15230

706 Rev. 5

620659

### 10.3 FORMAL INSPECTION

In a Formal Inspection, add the following step:

**Step 6:** Record the Miner's Belt inspection date, identity of the competent person inspector and the inspection results. Refer to the Formal Inspection Log in these instructions.

### 10.4 CORRECTIVE ACTION

When inspection reveals signs of inadequate maintenance, the Miner's Belt must be immediately removed from service and marked as "UNUSABLE" until destroyed or subjected to corrective maintenance. Defects, damage, excessive wear, malfunction and aging are generally not repairable. If detected immediately remove the Miner's Belt from use and mark it as "UNUSABLE" until destroyed. For final disposition, submit the Miner's Belt to a competent person who is authorized to perform Formal Inspection. If there is any question as to reliability, contact MSA, or a service center authorized in writing by MSA, before further use of the device.



**CAUTION**

*Only MSA or parties with written authorization from MSA may make repairs to the MSA Miner's Belt.*

### 10.5 MINER'S BELT INSPECTION DIAGRAM (SEE FIGURE 1)

- |  |   |   |
|--|---|---|
| 1. Friction Buckle                     | 7. No Inspection Required for this part.  | 13. Belt Tongue (Friction Buckle Belt)    |
| 2. Tongue Buckle (Tongue Buckle Belts) | 8. D-ring                                 | 14. Belt Tongue (Tongue Buckle Belt)      |
| 3. Keeper                              | 9. No Inspection Required for this part.  | 15. No Inspection Required for this part. |
| 4. Respirator Pack Strap & Buckle      | 10. Battery Pack Strap & Buckle           | 16. No Inspection Required for this part. |
| 5. I. D. & Inspection Tag              | 11. No Inspection Required for this part. | 17. Caution Label (D-ring)                |
| 6. Strap Loop                          | 12. Body Pad                              |   |

### 11.0 FORMAL INSPECTION LOG

Model No.: \_\_\_\_\_ Inspector: \_\_\_\_\_

Serial No.: \_\_\_\_\_ Inspection Date: \_\_\_\_\_

Date Made: \_\_\_\_\_ Disposition: \_\_\_\_\_

Comments: \_\_\_\_\_  
\_\_\_\_\_  
\_\_\_\_\_  
\_\_\_\_\_  
\_\_\_\_\_  
\_\_\_\_\_

### WARRANTY

**Express Warranty** – MSA warrants that the product furnished is free from mechanical defects or faulty workmanship for a period of one (1) year from first use or eighteen (18) months from date of shipment, whichever occurs first, provided it is maintained and used in accordance with MSA's instructions and/or recommendations. Replacement parts and repairs are warranted for ninety (90) days from the date of repair of the product or sale of the replacement part, whichever occurs first. MSA shall be released from all obligations under this warranty in the event repairs or modifications are made by persons other than its own authorized service personnel or if the warranty claim results from misuse of the product. No agent, employee or representative of MSA may bind MSA to any affirmation, representation or modification of the warranty concerning the goods sold under this contract. MSA makes no warranty concerning components or accessories not manufactured by MSA, but will pass on to the Purchaser all warranties of manufacturers of such components. THIS WARRANTY IS IN LIEU OF ALL OTHER WARRANTIES, EXPRESS, IMPLIED OR STATUTORY, AND IS STRICTLY LIMITED TO THE TERMS HEREOF. MSA SPECIFICALLY DISCLAIMS ANY WARRANTY OF MERCHANTABILITY OR FITNESS FOR A PARTICULAR PURPOSE.

**Exclusive Remedy** - It is expressly agreed that the Purchaser's sole and exclusive remedy for breach of the above warranty, for any tortious conduct of MSA, or for any other cause of action, shall be the repair and/or replacement, at MSA's option, of any equipment or parts thereof, that after examination by MSA are proven to be defective. Replacement equipment and/or parts will be provided at no cost to the Purchaser, F.O.B. Purchaser's named place of destination. Failure of MSA to successfully repair any nonconforming product shall not cause the remedy established hereby to fail of its essential purpose.

**Exclusion of Consequential Damages** - Purchaser specifically understands and agrees that under no circumstances will MSA be liable to Purchaser for economic, special, incidental, or consequential damages or losses of any kind whatsoever, including but not limited to, loss of anticipated profits and any other loss caused by reason of the non-operation of the goods. This exclusion is applicable to claims for breach of warranty, tortious conduct or any other cause of action against MSA.

For additional information please contact the Customer Service Department at 1-800-MSA-2222 (1-800-672-2222).