



	MODEL NO.	SERIAL NO.
STANCHION DAVIT ASSEMBLY	506677	
DAVIT MOUNTING RECEPTACLE	506678	

USER INSTRUCTIONS

MSA STANCHION MOUNT DAVIT SYSTEM

⚠ WARNING

National standards and state, provincial and federal laws require the user to be trained before using this product. Use this manual as part of a user safety training program that is appropriate for the user's occupation. These instructions must be provided to users before use of the product and retained for ready reference by the user. The user must read, understand (or have explained), and heed all instructions, labels, markings and warnings supplied with this product and with those products intended for use in association with it. FAILURE TO DO SO MAY RESULT IN SERIOUS INJURY OR DEATH.

1.0 STANCHION MOUNT DAVIT AND COMPANION COMPONENTS MODELS AND SPECIFICATIONS

TABLE 1. MSA STANCHION MOUNT DAVIT SYSTEM MODELS COVERED BY THESE INSTRUCTIONS

MODEL NUMBER	DESCRIPTION	MATERIAL	APPROXIMATE WEIGHT	
			LBS.	KG
506678	DAVIT MOUNTING RECEPTACLE	CARBON STEEL, ZINC PLATED	26	11
506677	STANCHION DAVIT ASSEMBLY	CARBON STEEL, ZINC PLATED	23	10

TABLE 2. MSA STANCHION MOUNT DAVIT SYSTEM COMPANION COMPONENTS COVERED BY THESE INSTRUCTIONS

MODEL NUMBER	DESCRIPTION	QTY PER ASSEMBLY	LIFELINE MATERIAL	APPROX WEIGHT	
				LBS.	KG
506619	BACKPACKER SELF-RETRACTING LANYARD (SRL)	1	POLYESTER	8	4
VARIOUS	DYNA BRAKE SHOCK ABSORBING LANYARDS	1 OR 2	NYLON, POLYESTER OR WIRE ROPE	2	1

1.1 SPECIFICATIONS - MSA STANCHION MOUNT DAVIT SYSTEM

- For use with floor anchorages and may be used with OSHA approved guard rails. Guard rails must be 1-1/4 in (3 cm), mid-rail section must be between 18 in (46 cm) and 24 in (61 cm) from the floor.
- Capacity is two persons, each weighing up to 310 lbs (141 kg) for personnel including weight of the user-borne objects. Maximum capacity is 620 lbs (242 kg).
- The stanchion davit assembly and davit mounting receptacle meet ANSI Z359.1-1992, ANSI A10.14-1991, and OSHA regulations dealing with fall arrest systems. These instructions and the labels on the products, fulfill the requirements of those standards and regulations.
- The stanchion davit system must be installed and used under the supervision of a qualified person. The criteria for determining a qualified person is established by OSHA.
- The stanchion davit assembly and davit mounting receptacle must be used together. They are designed to serve as an anchorage connector in a personal fall arrest system.
- Material used in construction of the stanchion davit assembly and davit mounting receptacle is (a) square structural steel tubing conforming to ASTM A500, Grade B and, (b) steel plate conforming to ASTM A36. Welds conform to AWS code specification. Plating conforms to ASTM B633. Hardware conforms to ASA B18.2.1-1965; bolts are SAE Grade 5.

2.0 TRAINING

It is the responsibility of the purchaser of the stanchion mount davit system to assure that product users are made familiar with these User Instructions and trained by a competent person in: (1) workplace hazard awareness and hazard identification, evaluation and control; (2) how to properly select, inspect, use, store and maintain the stanchion davit and associated equipment; (3) how to select and make connections to anchorages and anchorage connectors; (4) proper attachment locations and proper attachment methods including compatibility of connections to reduce the probability of accidental disengagement ("rollout"); (5) how to evacuate from a hazardous space; (6) what to do after a fall to protect the user from injury, including emergency rescue planning and execution; and (7) the consequences of improper use of the equipment and of failure to follow instructions and training. If the stanchion mount davit system is to be used for confined space applications, the user must also be trained in accordance with the requirements of OSHA regulation 29 CFR 1910.146 and ANSI Z117.1. Training must be conducted without undue exposure of the trainee to hazards. The effectiveness of training should be periodically assessed (at least annually) and the need for more training or retraining determined. MSA offers training programs. Contact MSA for training information.

3.0 HAZARDS IDENTIFICATION, EVALUATION AND CONTROL

CAUTION

Do not use the stanchion mount davit system unless a qualified person has inspected the workplace and determined that use of the stanchion davit is essential and that identified hazards can neither be eliminated nor exposures to them prevented.

Prior to selecting a stanchion mount davit system or other personal protective equipment, the user must make a workplace assessment of hazards and conditions where the equipment is required. Such assessment must, at a minimum, identify the presence of:

- Hot objects
- Sparks
- Flames
- Heat-producing operations
- Confined space hazards
- Chemicals
- Electrical hazards
- Environmental contaminants
- Sharp objects
- Abrasive surfaces
- Moving equipment
- Moving materials
- Unguarded openings
- Climatic factors
- Weather factors
- Unstable/uneven surfaces
- Slippery surfaces

Foreseeable changes in any of these conditions, taken individually or collectively, must be identified. The materials and construction of the stanchion mount davit system and associated equipment must be considered in the selection process such that these workplace conditions are suitably addressed and responded to. The equipment must match the work situation and workplace environmental factors.

The workplace assessment must identify all paths of intended user movement and all hazards along such paths. The user must identify the required range of mobility in each hazard zone and note the location and distance to all obstructions in potential fall paths. Lateral obstructions which could be contacted in a pendular fall arrest must be noted. The lanyard or self-retracting lanyard connecting the user's harness to the stanchion davit anchorage connection must be selected so as to suitably limit total fall distance. If the stanchion mount davit system is to be used for confined space entry operations, the workplace assessment must comply with the requirements of OSHA regulation 29 CFR 1910.146 and ANSI Z117.1.

4.0 DESCRIPTION OF STANCHION MOUNT DAVIT SYSTEM AND COMPANION COMPONENTS

- 4.1 STANCHION DAVIT ASSEMBLY:** The stanchion davit consists of a plated tube with steel plates for attachment of companion components. At the top of the davit are two factory-installed D-ring anchorage connectors. The removable davit is supported in the vertical position by the davit mounting receptacle. The stanchion davit assembly is designed to permit attachment of one Backpacker self-retracting lanyards, or up to two shock absorbing lanyards.
- 4.2 DAVIT MOUNTING RECEPTACLE:** The davit mounting receptacle is the means by which the stanchion davit assembly is attached to the floor anchorage. The receptacle is permanently secured to the floor by four anchor bolts (not provided). The davit mounting receptacle is constructed of plated steel tube with inside dimensions which allow clearance for inserting the stanchion davit assembly. Additional support is available by clamping onto the center rail of a guard rail using the threaded studs and alligator clamps provided.

- 4.3 **MOUNTING BRACKET FOR BACKPACKER SELF-RETRACTING LANYARD:** The stanchion davit assembly is equipped with one mounting bracket for attachment of the Backpacker SRL. The removable bracket is secured to the stanchion davit with a ball lock pin provided. The mounting bracket is constructed of zinc plated structural steel.
- 4.4 **BACKPACKER SELF-RETRACTING LANYARD:** The Backpacker SRL, MSA P/N 506619, is a fall arrester of the retractable lifeline type. The Backpacker consists of a metal housing and polyester strap lifeline connected to a drum inside the housing. An internal spring causes the drum to wind-up the line when there is no load on the line. An internal locking mechanism is designed to lock the drum when the line is pulled out quickly, which will occur in the case of an accidental fall by the user. Fall arrest forces are limited to 900 lbf (4 kN) or less. Capacity is one person, 75-310 lbs (34-140 kg). The Backpacker is available in a 20 ft (6 m) line length. The Backpacker housing is aluminum alloy. Internal components are principally carbon and alloy steel with a cast aluminum drum.

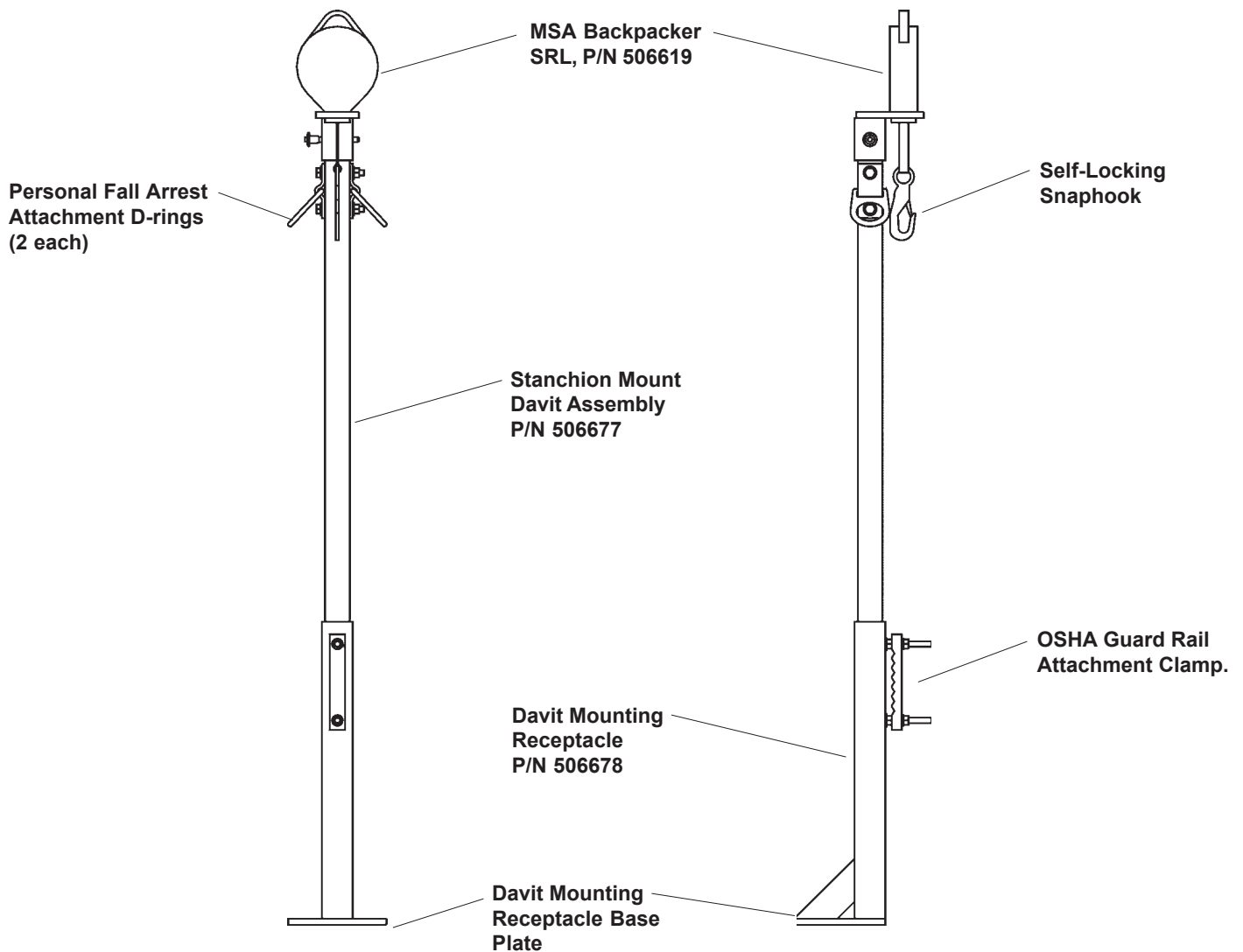

5.0 STANCHION MOUNT DAVIT SYSTEM SELECTION AND APPLICATIONS

- 5.1 **PURPOSE OF THE STANCHION MOUNT DAVIT SYSTEM:** The primary purpose of the stanchion mount davit system is to serve as an anchorage connector for personal fall arrest. Additionally, the stanchion mount davit system provides a means for anchoring an evacuation system and effecting personnel evacuation and may be used for ladder climbing fall arrest. Use of the stanchion mount davit system must comply with these User Instructions and, further, is subject to approval under the user's safety rules and regulations and by the user's safety director, supervisor, or a qualified person. Be certain the selection of the stanchion mount davit system is suited for the intended use and work environment. If there is any conflict

between these User Instructions and other directives or procedures of the user's organization, do not use the stanchion mounting system until such conflicts are resolved. Consult all local, state, and federal Occupational Health and Safety Administration (OSHA) requirements for personal safety equipment. Also refer to the latest revision of ANSI Z359.1 and ANSI A10.14 standards for more information on anchorage connectors and associated system components. In Canada, refer to provincial and federal regulations.

5.2 USAGE LIMITATIONS: The following application limitations must be considered and planned for before using the stanchion mount davit system.

5.2.1 PHYSICAL LIMITATIONS: The stanchion mount davit system is designed for use by two persons with a combined total weight less than 620 lbs (280 kg), including clothing, tools, and other user-borne objects. Persons with muscular, skeletal, or other physical disorders should consult a physician before using. Pregnant women and minors must never use the stanchion mount davit system. Increasing age and lowered physical fitness may reduce a person's ability to withstand shock loads during fall arrest or prolonged suspension. Consult a physician if there is any question about physical ability to safely use this product to arrest a fall or suspend.

5.2.2 CHEMICAL HAZARDS: Acidic, alkaline, or other environments with harsh substances may damage the plating and hardware elements of the stanchion mount davit system. When working in the presence of chemicals, more frequent inspection of the stanchion mount davit system is required.

5.2.3 CORROSION: Do not expose the stanchion mount davit system to corrosive environments for prolonged periods. Organic substances and salt water are particularly corrosive to metal parts. When working in corrosive environments, more frequent inspection, cleaning and drying of the stanchion mount davit system is required. See sections 9, 11 and 12 for cleaning and inspection details.

5.2.4 ELECTRICAL HAZARDS: Use extreme caution when working near energized electrical sources. Metal construction of the stanchion mount davit system and other components connected to it will conduct electric current. Maintain a safe working distance {preferably at least 10 ft (3 m)} from electrical hazards.

5.2.5 MOVING MACHINERY: When working about moving machinery (e.g. conveyors, rotating shafts, presses, etc.), maintain a safe working distance from machinery parts which could entangle clothing, this product, or other components connected to it.

5.2.6 WEAR AND DETERIORATION: Any stanchion mount davit system which shows signs of excessive wear or deterioration must be removed from use and marked "UNUSABLE" until repaired or destroyed. See sections 11 and 12 for detailed inspection procedures.

5.2.7 IMPACT FORCES: Any stanchion mount davit system which has been subjected to the forces of arresting a fall must be immediately removed from service and marked as "UNUSABLE" until (a) inspected and determined by a qualified person to be undamaged and suitable for reuse, or (b) returned to MSA for repair.

5.2.8 GENERAL PRECAUTIONS:

- This system must be installed and used under the supervision of a qualified person.
- If used with a guard rail, use only with a suitable OSHA approved guard rail.
- Use only with compatible MSA components.
- Do not expose the worker to hazard during installation and removal of the stanchion mount davit system.
- Connect no more than two (2) personal fall arrest subsystems to the stanchion mount davit system at one time.
- A separate and independent rescue and retrieval system is needed.

6.0 SYSTEMS REQUIREMENTS

The stanchion mount davit assembly and davit mounting receptacle are components of multi-component systems. Without the other necessary components, they serve no useful purpose. The stanchion mount davit assembly and davit mounting receptacle are used in fall arrest, climbing protection and evacuation. In general, however, the stanchion mount davit assembly and davit mounting receptacle are not intended for use in restraint, rescue or personnel-riding.

6.1 SYSTEM TYPES: Systems are classified according to their intended purposes. There are six classifications of systems which may be used individually or in combinations. The six basic systems classifications are:

- Personnel-riding
- Climbing protection
- Fall Arrest
- Restraint
- Rescue
- Evacuation

- 6.1.1 PERSONNEL-RIDING SYSTEMS:** A personnel-riding system is an assembly of components and subsystems, including the necessary connectors, used for lifting and lowering a worker to and from a work station which is not accessible by other preferred means, and potentially for positioning the worker while at that work station. Personnel-riding systems are of two general types, namely: (a) the mobile supported aerial platform type (e.g. manually- and self-propelled platforms and vehicle-mounted platforms), and (b) suspended personnel hoisting type (e.g. suspended scaffolds, suspension seats, and suspension harnesses). When working on mobile supported aerial platforms, the user should use a restraint system (see section 6.1.5) anchored to the platform to provide restraint against falling from the platform. When working with the suspended personnel hoisting type of system, the user should use a back-up a fall arrest system of either the self-retracting lanyard type or the fall arrester (rope grab) type. Contact MSA for separate instructions on the associated equipment used in personnel-riding systems. **The stanchion mount davit system is not suitable for use in personnel-riding systems.**
- 6.1.2 FALL ARREST SYSTEMS:** A fall arrest system is an assembly of components and subsystems, including the necessary connectors, used to arrest the user in a fall from a working height and suspend the user until rescue can be effected. A fall arrest system must always include a harness and connecting means between the harness and an anchorage or anchorage connector. Such connecting means may consist of a lanyard, energy (shock) absorber, fall arrester (rope grab), lifeline, self-retracting lanyard or suitable combinations of these.
- 6.1.2.1 Lanyard Connecting Subsystem** is the term applied to an assembly, including the necessary connectors, which is comprised of a lanyard and a shock absorber. The lanyard and shock absorber are usually permanently coupled together along with self-locking snaphooks at each end. The subsystem is attached between the fall arrest attachment (back D-ring) of the harness and an anchorage or anchorage connector. **The stanchion mount davit system may be used with compatible lanyard connecting subsystems.**
- 6.1.2.2 Fall Arrester Connecting Subsystem** is the term applied to an assembly, including the necessary connectors, which is comprised of a fall arrester (rope grab) and a vertical lifeline. Sometimes a lanyard or lanyard with integral shock absorber, including the necessary connectors, is connected to the rope grab. The vertical lifeline must have a lifeline tensioner (counterweight), a connector for anchoring it, and may have a shock absorber. The subsystem is attached between the fall arrest attachment (back D-ring) of the harness and an anchorage or anchorage connector. Fall arrester connecting subsystems are sometimes suitable for use in climbing protection systems. See section 6.1.2. Contact MSA for information on shock absorbing lanyards that are suitable for use in fall arrester connecting subsystems. **The MSA stanchion mount davit system is suitable for use in fall arrester connecting subsystems.**
- 6.1.2.3 Self-Retracting Lanyard Connecting Subsystem** is the term applied to an assembly, including the necessary connectors, comprised of a self-retracting lanyard only or a self-retracting lanyard and added shock absorber at the point of attachment to the user's harness. The subsystem is attached between the fall arrest attachment (back D-ring) of the harness and an anchorage or anchorage connector. These subsystems are sometimes suitable for use in climbing protection systems. See section 6.1.2. **The stanchion mount davit system is suitable for use in self-retracting lanyard connecting subsystems.**
- 6.1.3 RESCUE SYSTEMS:** A rescue system is an assembly of components and subsystems, including the necessary connectors, used for moving an incapacitated or isolated person from a hazardous place to a safe place under alert or emergency conditions. An isolated person is one who has no available means of access to a safe place or is physically stranded or trapped. Rescue systems require actions of specially trained rescuers to effect the rescue of the incapacitated or isolated person. **The stanchion mount davit system is not suitable for use in rescue systems.**
- 6.1.4 CLIMBING PROTECTION SYSTEMS:** A climbing protection system is an assembly of components and subsystems, including the necessary connectors, used to arrest the user in a fall from a working height and suspend the user until rescue can be effected. Such systems are used for climbing ladders and structures that are designed for climbing. They may either be temporary (portable) or permanent. Permanent climbing protection systems are ones of the rigid rail type such as the MSA Dyna-Glide™ systems. In those systems, a rigid rail is permanently attached to the structure to be climbed. A fall arrester device is attached to and glides on the rail to permit ascent and descent. It quickly locks in case of a fall. The Dyna-Glide fall arrester is attached between the front attachment (chest D-ring) of a MSA Pullover harness and the fall arrester by use of a carabiner. Contact MSA for more information about Dyna-Glide climbing protection systems. **The stanchion mount davit system is a suitable anchorage connector in a temporary climbing protection system.**
- 6.1.5 RESTRAINT SYSTEMS:** A restraint system is an assembly of components and subsystems, including the necessary connectors, used to:
- stabilize and partially support the user at an elevated work location and allow free use of both hands. This type of restraint system is referred to as a work positioning system or, simply, a positioning system.
 - restrict the user's motion so as to prevent reaching a location where a fall hazard exists. This type of system is referred to as a travel restriction system.

A positioning system includes a harness and connecting means between the harness and an anchorage or anchorage

connector. Such connecting means usually consists of a positioning lanyard which is connected to both hip D-rings and wraps around or connects to an anchorage or anchorage connector. A positioning system must always be backed up by a fall arrest system. A travel restriction system consists of a harness and a fixed-length or adjustable-length lanyard connected between any one of the harness D-rings and an anchorage or anchorage connector. **The stanchion mount davit system should not be used for work positioning or for travel restriction.**

6.1.6 EVACUATION SYSTEMS: An evacuation system is an assembly of components and subsystems, including the necessary connectors, employed by the user to move, unassisted by others, from a hazardous place to a safe place under alert or emergency conditions. An evacuation system consists of a harness and connecting means between the harness and an anchorage or anchorage connector. Such connecting means may consist of: (a) the MSA Dynescape™ Automatic Descender, (b) the MSA Dynescape™ Manual Descender, or (c) the MSA Fallbloc™ System. See the separate instructions for this equipment. **The stanchion mount davit system is suited for use in evacuation systems.**

6.1.7 COMBINATIONS OF SYSTEMS: Systems for fall arrest, restraint, climbing protection, personnel-riding, rescue and evacuation are often used in combination. For example, positioning type restraint systems must be backed up by a separate and independent fall arrest system. Hands-on training is required to obtain the necessary information and skills needed to work with combinations of systems. Refer to the separate instructions accompanying the several components and subsystems necessary to make up these systems.

6.2 COMPATIBILITY OF SYSTEM PARTS

6.2.1 COMPATIBILITY OF COMPONENTS AND SUBSYSTEMS: MSA stanchion mount davit system is designed to be used with other MSA approved components and connecting subsystems. Use of the stanchion mount davit system with products made by others that are not approved in writing by MSA may adversely affect the functional compatibility between system parts and the safety and reliability of the complete system. Contact MSA with any questions regarding compatibility of equipment used with the stanchion mount davit system.

6.2.2 COMPATIBILITY OF CONNECTORS: Connectors, such as D-rings, snaphooks, and carabiners, must be rated at 5,000 lbf (22 kN) minimum breaking strength. MSA connectors meet this requirement. Connecting hardware must be compatible in size, shape, and strength. Non-compatible connectors may accidentally disengage ("rollout").

6.2.3 ANCHORAGES AND ANCHORAGE CONNECTORS: An anchorage is generally a fixed structural member such as a beam, girder, column, floor, or wall. **The stanchion mount davit system is an anchorage connector for personal fall arrest systems.** Anchorages and anchorage connectors for personal fall arrest systems must have a strength capable of supporting a static load, applied in directions permitted by the system, of at least: (a) 3,600 lbf (16 kN) when certification exists, or (b) 5,000 lbf (22.2 kN) in the absence of certification. See ANSI Z359.1 for definition of certification. When more than one personal fall arrest system is attached to an anchorage, the anchorage strengths set forth in (a) and (b) must be multiplied by the number of systems attached to the anchorage. See ANSI Z359.1, section 7.2.3. This requirement is consistent with OSHA requirements under 20 CFR 1910, Subpart F, Section 1910.66, Appendix C. In addition, it is recommended that the user of personal fall arrest systems refer to ANSI Z359.1, Section 7, for important considerations in equipment selection, rigging, use, and training.

7.0 PLANNING THE USE OF SYSTEMS

Perform the hazard identification and evaluation described in section 3 of these instructions. Then plan the system(s) before starting work. Consider all possible paths of user movement and all factors that could affect the user's safety before, during, and after a fall anywhere along these paths. A qualified person must select the components, materials, anchorage and anchorage connectors to match the system application, the work, workplace hazards, and the environment. Consider the following points when planning the system(s).

7.1 ANCHORAGE AND ANCHORAGE CONNECTOR SELECTION: Determine the necessary locations of anchorages to assure that the user will be continuously connected when exposed to hazards of falling. Select anchorages that are stable and have the strength required by section 6.2.3 of these instructions. Carefully select the locations of the anchorages to: (a) reduce possible free fall distance, (b) prevent swing fall hazards, and (c) provide clear space in the potential fall paths to avoid striking an object. Do not select anchorage locations that will require the user to work above them as this will increase the potential free fall and total fall distances. Plan the types of anchorage connectors that will need to be selected and refer to those instructions.

7.2 FREE FALL DISTANCE, TOTAL FALL DISTANCE, AND SYSTEM ELONGATION: Personal fall arrest systems must be selected and rigged to ensure that potential free fall distances will never exceed 6 ft (1.8 m) as required by OSHA and ANSI Z359.1. [In Canada, free fall distance is limited to 5 ft (1.5 m) by regulation. ANSI A10.14 also restricts free fall distance to 5 ft (1.5 m).] Total fall distance is the sum of free fall distance and deceleration distance. Dynamic elongation of the system (temporary elastic stretch of connecting components and subsystems) must be included in the total fall distance and the user must allow for clearance.

- 7.3 **USER MOVEMENTS:** Identify all necessary movements of the user and the materials and equipment needed to perform the planned work. Plan for avoidance of the crossing or tangling of connecting subsystems of two or more workers. Anticipate user movements that might introduce hazards of the connecting subsystem passing under, about or between body parts or invite the user to clamp, knot or otherwise prevent the connecting subsystem from functioning properly. Establish controls to prevent these occurrences.
- 7.4 **PENDULUM (SWING) FALLS:** Swing falls can occur when the system is not anchored directly above the user. The force of striking an object in a pendular motion can cause serious injury. Always minimize swing falls by working as directly below the anchorage point as possible.

Swing Fall Hazard

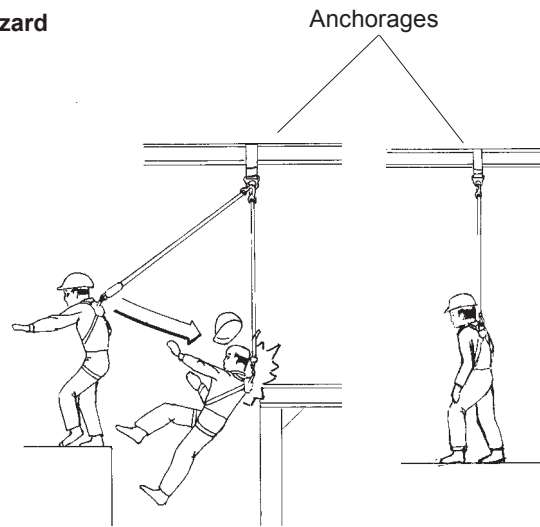

Swing fall hazards must be minimized by anchoring directly above the user's work space.

- 7.5 **CLEAR SPACE IN FALL PATH:** Make certain that enough clearance is available in all potential fall paths to prevent striking an object. The amount of clearance needed depends upon the type of connecting subsystem used, and the location of the anchorage. Allow at least 40 in (1 m) below the user and within a radius of 6 ft (1.8 m). This allows for some horizontal motion during the fall even if there is no swing fall possible.
- 7.6 **HAZARDS IDENTIFIED IN WORKPLACE ASSESSMENT:** All hazards of the type set forth in section 3 of these instructions must be addressed and suitable controls planned and implemented. For example, if work must be performed near unavoidable sharp edges, plan to protect against cutting by use of heavy padding or other means of covering the sharp edge.
- 7.7 **RESCUE AND EVACUATION:** The user must have a rescue plan and the means at hand to implement it. The plan must take into account the equipment and special training necessary to effect prompt rescue under all foreseeable conditions. If the rescue is from a confined space, the provisions of OSHA regulation 1910.146 and ANSI Z117.1 must be taken into account. Although a rescue plan and the means to implement it must always be in place, it is a good idea to provide means for evacuation without assistance of others. This will usually reduce the time to get to a safe place and reduce or prevent the risk to rescuers. The stanchion mount davit system is suitable for use in evacuation systems but is not used in rescue systems.

8.0 INSTALLATION AND USE

⚠ CAUTION

Do not expose workers to fall hazards during installation. A separate personal fall arrest system is required for each installation worker. The stanchion mount davit system must be installed and used under the supervision of a qualified person.

8.1 INSTALLING THE DAVIT MOUNTING RECEPTACLE: Equipment required to complete the installation includes: wrench, 3/4 inch size. Selection of the anchorage and installation of the davit mounting receptacle must be done under the supervision of a qualified person. The user is responsible for providing an anchorage as described in section 6.2.3 of these instructions. The user must prepare the anchorage for use by providing a matching hole pattern in the anchorage for anchor bolts. The anchor bolts must be 1/2 in (1.3 cm) diameter and of strength sufficient to support loads applied in directions permitted by the system.

Step 1: Align the base receptacle over the anchorage hole pattern and secure with four suitable anchor bolts. The installed base should be vertical when completed.

**Davit Mounting Receptacle Hole Pattern
(Dimensions in Inches)**

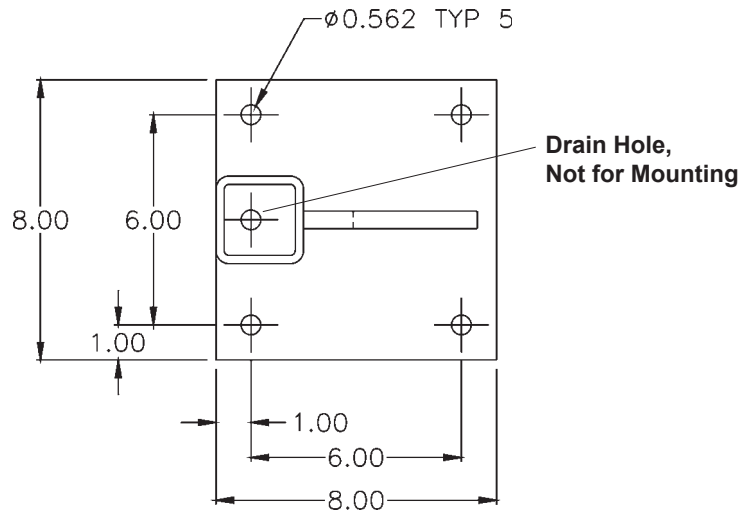

Step 2: If an OSHA approved guard rail is available, position alligator clamp around the middle rail and tighten nuts on the two studs to secure the clamp. Torque nuts to 50 ft-lbs (67 N-m) or until the clamps are deformed about the rail.

**Exploded View Diagram of
Rail Clamp**

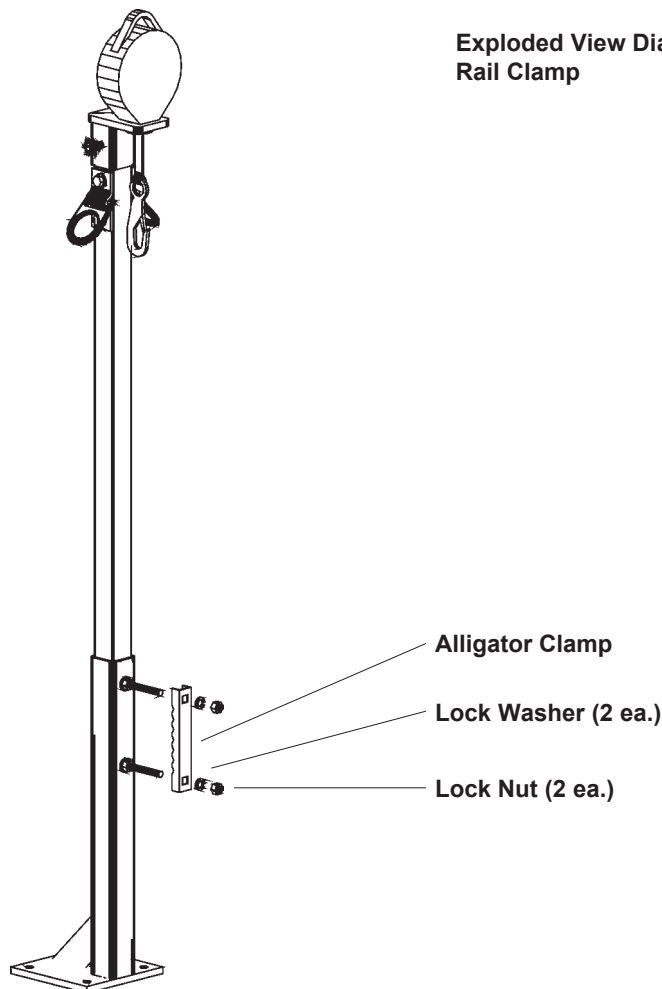

Step 3: Inspect the installation. Verify all parts are present and properly secured before use.

8.2 INSTALLATION OF THE STANCHION DAVIT ASSEMBLY: No special equipment is required to complete the installation. The base receptacle must be installed prior to beginning this step, see section 8.1. Approximately 8 ft (2.4 m) of overhead clearance is required to install the stanchion davit.

Step 1: Lift the vertical davit assembly straight above the davit mounting receptacle and lower the davit slowly into the receptacle tube. Seat the stanchion davit fully to the markings on the inner tube of the assembly.

Step 2: Inspect the installation. Verify that all parts are present and properly secured before use.

8.3 ATTACHING THE BACKPACKER TO THE STANCHION DAVIT ASSEMBLY: No special equipment is required to complete the installation.

Step 1: Reeve the snaphook of the Backpacker through the hole in the mounting bracket and seat the nozzle into the mounting bracket.

Step 2: Push down on the Backpacker housing until the tabs on the sides of the nozzle click and lock on the underside of the mounting bracket. Check to verify the nozzle is seated and locked.

Step 3: Check the operation of the Backpacker by extracting 3 ft (1 m) of line and releasing. Repeat this operation three times to witness the function of the unit and that it is working properly.

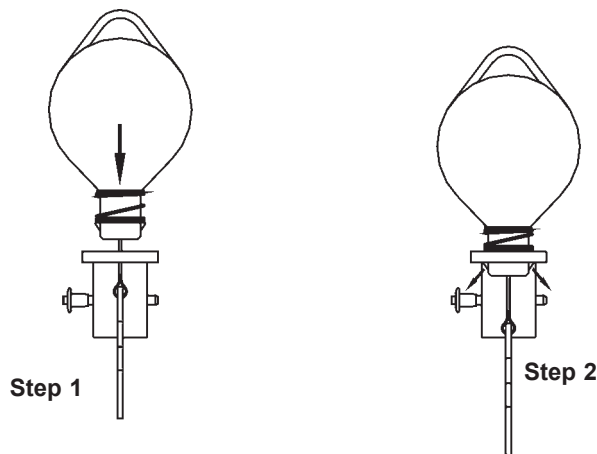

Step 4: Inspect the installation. Verify that all parts are present and properly secured before use.

⚠ CAUTION

Read and understand Backpacker User Instructions, P/N 622711, before using this equipment.

8.4 INSTRUCTIONS FOR USE:

⚠ CAUTION

- Do not exceed the maximum capacity of 620 lbs (282 kg) including personnel, tools and other user-borne objects.
- Do not connect more than two persons to the stanchion davit mounting system at one time.

8.4.1 LANYARD CONNECTING SUBSYSTEM FOR FALL ARREST: When using the Backpacker self-retracting lanyard, assemble the Backpacker to the mounting bracket of the stanchion davit and connect the snaphook of the lifeline to the back D-ring of the user's full body harness. When using a compatible shock absorbing lanyard, connect the snaphook on the shock absorber end to the back D-ring of the user's full body harness, then connect the other snaphook to one of the two D-rings on the top of the stanchion davit.

- 8.4.2 LADDER CLIMBING FALL ARREST:** Connect self retracting lanyard (SRL) to the front (chest) D-ring of the worker's full body harness. Connect to the SRL before entering the fall hazard zone. When ladder climbing, the SRL will automatically pay out and reel-in line. Do not allow a slack-line condition to develop; lifeline must be under tension while climbing. Use care to avoid tangling the line of another worker on the same system. When not in use, the SRL line should be allowed to retract back into the housing.

In the event of a fall, the SRL will lock automatically, arresting the fall within 24 inches (61 cm). The worker should regain contact with the ladder, if possible, and immediately evacuate to a safe working level. If the suspended worker is incapacitated, rescue efforts must be initiated (see section 8.4.3). Contact MSA with any questions regarding the suitability for use of stanchion mount davit system components.

- 8.4.3 EVACUATION:** There are two suitable MSA evacuation systems available for use with the stanchion davit: MSA Fallbloc Fall Arrest/Emergency Descent System, P/N 501500 or, the MSA Dynescape Manually-controlled Descender, P/N 506416. The attachment element for both of these systems is one of the D-rings mounted to the sides of the davit tube. See separate instructions for installation and use.
- 8.4.4 EMERGENCY RESCUE:** A separate and independent means for emergency rescue and retrieval is needed when using the stanchion davit system. If the worker is incapacitated, a means must be available to lift or lower the worker to the nearest safe working level.
- 8.4.5 DISASSEMBLING THE STANCHION MOUNT DAVIT SYSTEM:** To disassemble the components of the stanchion mount davit system, reverse the steps in the installation instructions given earlier in section 8. Do not leave the components of the system in place for prolonged periods in a corrosive environment. Inspect the system at disassembly, as described in section 11, before stowing. Stow the equipment in a clean dry area when not in use.

! CAUTION

Do not connect a snaphook into the ring of the Backpacker mounting bracket, as this may result in accidental disengagement ("rollout").

9.0 CARE, MAINTENANCE, AND STORAGE

User maintenance consists of cleaning and drying the stanchion mount davit system. All other maintenance or repair work must be done at the factory or by persons authorized in writing by MSA.

- 9.1 CLEANING INSTRUCTIONS:** To clean, periodically use a clean damp (not wet) cloth to remove dirt or contamination which may cause corrosion or hamper readability of labels. Wipe off any moisture before returning the device to service. The frequency of cleaning should be determined by inspection and by severity of the environment. In highly corrosive environments cleaning should be done every two or three days. Never use solvents to clean stanchion mount davit system as they may break down the label adhesive. Don't use abrasives to scour the stanchion mount davit system as they may damage the plating and the labels. To remove oil or grease, use a mild dishwasher detergent on a damp cloth or sponge and follow by repeated swabbing with a clean damp cloth to remove all soap residue. Never immerse the product in water or other liquid.
- 9.2 STORAGE:** Store the device in a clean, dry place indoors. Store the product away from heat and steam and never allow it to rest for lengthy periods of time on concrete or ash floors as the lime sulfur and ash can cause corrosion.

10.0 MARKINGS AND LABELS

- 10.1** The following labels must be present, legible, and securely attached to the stanchion mount davit system.



VERTICAL DAVIT ASSEMBLY ID and Caution Labels



Model: 506678
Material: Carbon Steel, Zinc Plated
Capacity: Two person, each with a combined total weight no greater than 310 lbs (141 kg), including clothing, tools, and other user-borne objects. Max. capacity is 620 lbs (282 kg).
Length: 2.0 ft (0.6 m)
Approx. net weight: 26.0 lb (11.8 kg)
 Use only with MSA Stanchion Davit Assembly (P/N 506677).

INSTALLATION-
 Note: The installation and use of the stanchion mount davit system must be performed under the supervision of a qualified person. Select a flat anchorage of suitable strength and size to install this anchorage connector. Refer to User instructions provided with this product.
Step 1: Align davit mounting receptacle vertically over the hole pattern in the anchorage. Secure with anchor bolts (user supplied) and check that the installation is vertical.
Step 2: If guard rail is available, attach alligator clamp to mid-rail of OSHA approved guard rail and tighten nuts on studs (provided). Tighten to 50 ft-lb or until clamps deform.
Step 3: Inspect completed davit installation. Verify all parts are present and properly secured before use.

DATE OF MANUFACTURE				
YR	1998	1999	2000	2001
MTH	JAN	FEB	MAR	APR
	MAY	JUN	JUL	AUG
	SEP	OCT	NOV	DEC

MSA Fall Protection,
 2250 S. Tejon St., Englewood,
 CO 80110-1000,
 1-800-672-2222

P/N 623142



READ AND HEED ALL INSTRUCTIONS, LABELS, MARKINGS AND WARNINGS SUPPLIED WITH THIS PRODUCT AND WITH THOSE PRODUCTS INTENDED FOR USE IN ASSOCIATION WITH IT. FAILURE TO DO SO MAY RESULT IN SERIOUS INJURY OR DEATH.

- For personnel use only, not for materials handling.
- Do not exceed maximum working loads. See User Instructions and davit labels.
- Install and use under the supervision of a qualified person. Have a rescue plan. Users must be trained in fall protection, lifting/lowering, communication, rescue and evacuation procedures.
- Do not use near electrical hazards.
- Lifelines must not contact sharp edges or abrasive surfaces.

INSPECTION-
 Before each use inspect entire davit, including attached Dyna-Lock, according to User Instructions. Look for damage, alteration, missing or broken parts, excessive wear and corrosion. Inspect anchorage and anchor bolts and ladder and ladder standoffs for cracks, breaks, loose or missing parts. **Never use davit if any of these conditions exist.** Do not attempt field repairs of davit assembly. Formally inspect by a competent person other than the user at least every six months. Note successful completion of formal inspection by punching date on grid. If davit fails inspection, remove from use and label "UNUSABLE" until repaired or destroyed.



FORMAL INSPECTION GRID

	J	F	M	A	M	J	J	A	S	O	N	D
98												
99												
00												
01												
02												

PUNCH GRID ON DATE OF FIRST USE

Made in U.S.A.
 P/N 623141

DAVIT MOUNTING RECEPTACLE ID and Caution Labels



Model: 506677
Material: Carbon Steel, Zinc Plated
Capacity: Two person, each with a combined total weight no greater than 310 lbs (141 kg), including clothing, tools, and other user-borne objects. Max. capacity is 620 lbs (282 kg).
Length: 5.5 ft (1.7 m)
Approx. net weight: 23.0 lb (10.5 kg)
 Use only with MSA Davit Mounting Receptacle (P/N 506678). Compatible with MSA Dyna-Lock self-retracting lanyard P/N 506619 and with MSA lanyards and DynaBrake shock absorbing lanyards.

INSTALLATION-
Step 1: Assemble the stanchion davit assembly into the base receptacle. Check to see that the tube is seated into the base fully to the bottom of the caution label. Approx. 8 ft (2.5 m) ceiling height is required to assemble the davit.
Step 2: Inspect completed davit installation. Verify all parts are present and properly secured before use.

INSPECTION-
 Before each use inspect entire davit, including attached Dyna-Lock, according to User Instructions. Look for damage, alteration, missing or broken parts, excessive wear and corrosion. Inspect anchorage and anchor bolts and ladder and ladder standoffs for cracks, breaks, loose or missing parts. **Never use davit if any of these conditions exist.** Do not attempt field repairs of davit assembly. Formally inspect by a competent person other than the user at least every six months. Note successful completion of formal inspection by punching date on grid. If davit fails inspection, remove from use and label "UNUSABLE" until repaired or destroyed.

INSTRUCTIONS FOR USE -

- For lanyard connecting subsystems, connect suitable lanyard snap-hook to back D-ring of full body harness and opposite end snap-hook to one of the D-rings on the stanchion davit.
- For climbing protection systems, assemble Backpacker Dyna-Lock, MSA P/N 506619 into mounting bracket, seat and lock securely. Attach snaphook to front (chest) D-ring of full body harness.
- For rescue or retrieval, a separate and independent system is needed. Such systems must be designed and installed under the supervision of a qualified person. A separate system should be planned and installed prior to stanchion davit system use, where needed.

DATE OF MANUFACTURE				
YR	1998	1999	2000	2001
MTH	JAN	FEB	MAR	APR
	MAY	JUN	JUL	AUG
	SEP	OCT	NOV	DEC

MSA Fall Protection,
 2250 S. Tejon St., Englewood,
 CO 80110-1000,
 1-800-672-2222

P/N 623140



READ AND HEED ALL INSTRUCTIONS, LABELS, MARKINGS AND WARNINGS SUPPLIED WITH THIS PRODUCT AND WITH THOSE PRODUCTS INTENDED FOR USE IN ASSOCIATION WITH IT. FAILURE TO DO SO MAY RESULT IN SERIOUS INJURY OR DEATH.

- For personnel use only, not for materials handling.
- Do not exceed maximum working loads. See User Instructions and davit labels.
- Install and use under the supervision of a qualified person. Have a rescue plan. Users must be trained in fall protection, lifting/lowering, communication, rescue and evacuation procedures.
- Do not use near electrical hazards.
- Lifelines must not contact sharp edges or abrasive surfaces.

INSPECTION-
 Before each use inspect entire davit, including attached Dyna-Lock, according to User Instructions. Look for damage, alteration, missing or broken parts, excessive wear and corrosion. Inspect anchorage and anchor bolts and ladder and ladder standoffs for cracks, breaks, loose or missing parts. **Never use davit if any of these conditions exist.** Do not attempt field repairs of davit assembly. Formally inspect by a competent person other than the user at least every six months. Note successful completion of formal inspection by punching date on grid. If davit fails inspection, remove from use and label "UNUSABLE" until repaired or destroyed.



FORMAL INSPECTION GRID

	J	F	M	A	M	J	J	A	S	O	N	D
98												
99												
00												
01												
02												

PUNCH GRID ON DATE OF FIRST USE

Made in U.S.A.
 P/N 623141

11.0 INSPECTION BEFORE EACH USE

- 11.1 INSPECTION FREQUENCY:** The stanchion mount davit system must be inspected by the user before each use and, additionally, by a competent person other than the user at intervals of no more than six months. The competent person inspection is referred to as Formal Inspection. See section 12 for Formal Inspection procedures.

CAUTION

If the stanchion mount davit system has been subjected to fall arrest or impact forces, it must be immediately removed from service and marked as "UNUSABLE" until evaluated and disposition made by a competent person within the user's organization.

- 11.2 PROCEDURE FOR INSPECTION BEFORE EACH USE:** Perform the following steps in sequence. If in doubt about any inspection point, consult MSA or a competent person who is qualified to perform Formal Inspection as set forth in section 12.
- 11.2.1 FLOOR ANCHORAGE:** Visually inspect the floor and anchor bolts for cracks, breaks, deformation, alteration and missing or damaged parts. Do not use if inspection reveals an unsafe condition.
- 11.2.2 DAVIT MOUNTING RECEPTACLE:** Inspect for damaged welds by visually examining each weld area for signs of cracking. Visually examine the entire assembly for deformed, altered or damaged parts. Inspect labels to verify that they are present and legible. Verify that there no obstructions which would prevent installation of the stanchion davit assembly. Verify that the mounting receptacle is mounted correctly on the floor anchorage and that, if a rail is available, all nuts are present and tightened to 50 ft-lbs (67 N-m). Do not use if inspection reveals an unsafe condition.
- 11.2.3 STANCHION DAVIT:** Visually inspect the entire length of the davit tube for cracks, breaks, corrosion or permanent deformation. Inspect the welds also for signs of cracking. Verify labels are present and legible. Inspect the D-ring anchorage connectors and the mounting bracket for cracks, breaks, corrosion, alteration and missing or damaged parts. If the davit is installed in the mounting receptacle, verify that the inner tube is fully seated into the base receptacle. Do not use if inspection reveals an unsafe condition.

CAUTION

Formally inspect all components by a competent person other than the user at intervals of no more than six months. See section 12 for inspection procedures.

If inspection reveals any defect, remove the device from service and label "UNUSABLE" until it is repaired or destroyed. The stanchion mount davit systems are not field repairable. Never attempt the field repairs. Return the defective part(s) to MSA, or to persons authorized in writing by MSA for repair.

12.0 FORMAL INSPECTION

- 12.1 FORMAL INSPECTION FREQUENCY:** The stanchion mount davit system must be formally inspected by a competent person other than the user at intervals of no more than six months. (The qualifications of a competent person are established by OSHA.) If the product is exposed to severe working conditions, more frequent formal inspections may be required. The frequency of inspection by a competent person should be established by the user's organization based on such factors as the nature and severity of workplace conditions, modes of use, and exposure time of the equipment. The competent person should perform a methodical and thorough visual and tactile inspection by following the inspection procedure in section 12.3. The inspection results should be recorded in the Formal Inspection Log and retained for reference. In addition, if the stanchion davit system passes formal inspection, the competent person should mark the date (month/year) of formal inspection on the grid printed on the label attached to each component of the system. The user should never record this data; however, the user should check it before each use to be sure a Formal Inspection has been performed within the last six months.
- 12.2 CONTROL OF EQUIPMENT:** The user's organization should establish and enforce a policy and procedure whereby any stanchion mount davit system that is found to be defective, damaged, or in need of maintenance be immediately removed from use, marked as "UNUSABLE" and immediately thereafter submitted to custody of the competent person responsible for Formal Inspection. This has the benefits that: 1) defective equipment is secured from further use until proper action is taken; 2) uniform standards are applied for determining whether the equipment is acceptable or not acceptable for further use; 3) uniform methods of cleaning and other maintenance are applied; and 4) there is a central point for evaluation of conditions that may be recurring and require preventive measures such as coordination with the equipment manufacturer, selection of alternate equipment, additional training of equipment users, or changes to the workplace conditions.

12.3 FORMAL INSPECTION PROCEDURE: The Formal Inspection Procedure is similar to the user's inspection before each use described in section 11. However, it differs in three important respects, namely: 1) it is performed by a competent person other than the user who is trained and authorized to perform Formal Inspection for the user's organization; 2) it is more detailed and is methodically recorded on a Formal Inspection Log that is kept on file for future reference; and 3) it results in final disposition of the equipment as either "acceptable" (indicated by the formal inspector recording the current month/year in the Formal Inspection Grid on one of the product labels), or as "not acceptable" followed by destruction of the product. The described detailed inspection record keeping is needed in order to trace detected defects to their causes. A simplified alternative procedure is also explained below.

There are three forms that are important to the Formal Inspection Procedure. They are the Formal Inspection Diagram ("DIAGRAM"), the Formal Inspection Log ("LOG"), and the Formal Inspection Checklist and Codes ("CHECKLIST"). These forms relate and refer to each other so it is necessary to understand their purposes and uses before discussing the inspection procedure.

12.3.1 DIAGRAM: This is a drawing of the stanchion mount davit system. It has numbered callouts of the parts. The numbers called out in the DIAGRAM correspond to those shown on the column titled "INSP. POINT" (inspection point) on the LOG.

12.3.2 LOG: This is the form to be used to record observations made during the Formal Inspection. The Model No., Serial No. and Date Made are recorded by the inspector from the label set. The formal inspector's name and the inspection date are entered by the inspector. The "Disposition" entry is the last entry made on this form after all observations have been recorded. The entry is either "Acceptable" ("PASS") or "Not Acceptable" ("FAIL"). The columns on the LOG are as follows:

INSP. POINT - Inspection point. The stanchion mount davit system part designated in the callouts on the DIAGRAM.

DESCRIPTION - Name of the stanchion mount davit system inspection point. There are two broad categories of inspection points, namely, metallic parts, and plastic parts. There are subcategories under these two main categories.

QTY/SMDS - Quantity per stanchion mount davit system. This is the number of inspection points on each stanchion mount davit system which must be inspected.

COND. - Condition. The condition of the stanchion mount davit system part is indicated here by entry of the appropriate Condition Code shown on the CHECKLIST (e.g. M0, etc.). Alternatively, the inspector may simply enter "FAIL" if a defective condition exists and make no entry if no defect exists.

OVERALL ASSESS. - Overall assessment. The inspector's evaluation of the overall acceptability or non-acceptability of the part category (i.e. metallic, plastic). The appropriate Overall Assessment Code defined on the CHECKLIST is entered here (e.g. MA, PN). Alternatively, the inspector may simply enter "FAIL" if a defective condition exists and make no entry if no defect exists.

COMMENTS - Indicate pertinent inspector observations here.

12.3.3 CHECKLIST AND CODES: This is a table which categorizes the different types of stanchion mount davit system parts into broad categories (e.g. metallic, plastic). For each of these categories that are applicable to a specific product, the formal inspector checks the stanchion mount davit system parts for each of the associated conditions (e.g. cracks, deformation, wear, etc.). The codes for the detected conditions are entered in the Condition column on the LOG (e.g. M0, etc.). Overall assessment codes are given, along with the criteria for assigning them, so the inspector can decide if the stanchion mount davit system is acceptable or not acceptable for further use (e.g. MA, PN). Alternatively, instead of using these codes, the inspector may simply enter "FAIL" if a defective condition exists and make no entry if no defect exists.

12.3.4 FORMAL INSPECTION PROCEDURAL STEPS:

Step 1: Record on the LOG the Model No., Serial No. and Date Made information shown on the product label set. Record the inspector's name and inspection date.

Step 2: Arrange the stanchion mount davit system so the parts to be inspected are readily visible.

Step 3: Starting with the metallic category of parts shown on the LOG, inspect each part (inspection point) one at a time. Refer to the DIAGRAM for identification of each inspection point. Each part must be inspected for the possible presence of the conditions shown on the CHECKLIST. Enter in the Condition column on the LOG the proper Condition Code (listed on the CHECKLIST) or "FAIL" if a defect exists. If there is any question whether the product has materially changed since the last Formal Inspection, retrieve and review the prior Formal Inspection records for the specific product.

Step 4: Repeat Steps 2 and 3 for the plastic categories of part types.

- Step 5:** Determine whether the part (inspection point) is acceptable or not acceptable. If an inspection point has a defective condition, enter in the Overall Assessment column of the LOG the proper code taken from the CHECKLIST (e.g. WN, SN, MN, PN) or simply "FAIL."
- Step 6:** Determine disposition of the stanchion mount davit system. If in step 5 it has been determined that the stanchion mount davit system is not acceptable, enter "N" or "FAIL" in the Disposition space on the LOG. In addition, a notation should be made in this space as to whether the stanchion mount davit system is to be destroyed, returned to manufacturer/distributor, etc.
- Step 7:** If in step 5 it has been determined that the stanchion mount davit system is acceptable for further use, enter "A" or "PASS" in the Disposition space on the LOG.
- Step 8:** File the LOG for future reference.

12.4 FORMAL INSPECTION CHECKLIST AND CODES

TYPE OF PART INSPECTED	CONDITION	COND. CODE	OVERALL ASSESSMENT CODE	LEGEND
Metallic	Deformed/fractured	M1	MA - (Metallic acceptable) MN - (Metallic not acceptable)	Disposition: A - (Acceptable) N - (Not acceptable) Enter "A" (or "PASS") or "N" (or "FAIL") in Disposition blank on Formal Inspection Log.
	Corroded/deep pits	M2		
	Missing/loose	M3		
	Heat exposure	M4		
	Chemical exposure	M5		
	Burrs/sharp edges	M6		
	Cuts/deep nicks	M7		
	Malfunction	M8		
	Other	M9		
	No visible change	M0		
Plastic	Cut/broken/deformed	P1	PA - (Plastic acceptable) PN - (Plastic not acceptable)	Criteria for disposition of "N" (Not acceptable): If there is one or more Overall Assessment Code of "N" type (e.g. WN, SN, MN, PN).
	Wear damage	P2		
	Missing/loose	P3		
	Burns/heat exposure	P4		
	Chemical exposure	P5		
	Other	P6		
	No visible change	P0		

12.5 FORMAL INSPECTION LOG FOR MSA STANCHION MOUNT DAVIT SYSTEM, EXAMPLE

FORMAL INSPECTION LOG FOR MSA DAVIT MOUNTING RECEPTACLE

Model No.: 506667 Inspector: J. W. Doe
 Serial No.: D01001K Inspection Date: 12/15/96
 Date Made: 6/96 Disposition: N - See item 2, Return to MSA.

INSP. POINT	DESCRIPTION	QTY/ VMDS	COND. (a)	OVERALL ASSESS.(a)	COMMENTS
METALLIC PARTS					
1	Steel Tube	1	M0	MA	
2	Mounting Plate & Gusset	1	M1	MN	Weld Cracked
3	Clamp	1	M0	MA	
4	Bolt	2	M0	MA	
5	Nut, 1/2" -13UNC	4	M0	MA	
6	Washer, flat, 1/2" dia.	2	M0	MA	
7	Washer, lock, 1/2" dia.	2	M0	MA	
PLASTIC PARTS					
8	Labels	2	P0	PA	

FORMAL INSPECTION LOG FOR STANCHION DAVIT ASSEMBLY

Model No.: 506668 Inspector: J. W. Doe
 Serial No.: D01001L Inspection Date: 12/15/96
 Date Made: 6/96 Disposition: N - See item 1, Return to MSA.

INSP. POINT	DESCRIPTION	QTY/ VMDS	COND. (a)	OVERALL ASSESS.(a)	COMMENTS
METALLIC PARTS					
9	Steel Tube	1	M2	MN	Severe corrosion
10	Mounting Bracket	1	M0	MA	
11	Bracket Ball Lock Pin	1	M0	MA	
12	D-ring	2	M0	MA	
13	D-ring Plate	2	M0	MA	
14	Bolt	2	M0	MA	
15	Washer, flat, 1/2" dia.	4	M0	MA	
16	Nut, locking, 1/2"	2	M0	MA	
PLASTIC PARTS					
17	Label	4	P0	PA	

- (a) Optional simplified PASS/FAIL inspection format: Whenever an acceptable condition is found, the entry in the COND. and OVERALL ASSESS. columns may be left blank. Whenever a defective condition is found, enter "FAIL." The inspection may end upon detection of a single defective condition.
- (b) Blank copies of this LOG, with associated CHECKLIST and DIAGRAM, are available from MSA. Call Toll Free 1-800-672-2222.

12.5 FORMAL INSPECTION LOG FOR MSA STANCHION MOUNT DAVIT SYSTEM**FORMAL INSPECTION LOG FOR MSA DAVIT MOUNTING RECEPTACLE**

Model No.: _____ Inspector: _____
 Serial No.: _____ Inspection Date: _____
 Date Made: _____ Disposition: _____

INSP. POINT	DESCRIPTION	QTY/ VMDS	COND. (a)	OVERALL ASSESS.(a)	COMMENTS
METALLIC PARTS					
1	Steel Tube	1			
2	Mounting Plate & Gusset	1			
3	Clamp	1			
4	Bolt	2			
5	Nut, 1/2" -13UNC	4			
6	Washer, flat, 1/2" dia.	2			
7	Washer, lock, 1/2" dia.	2			
PLASTIC PARTS					
8	Labels	2			

FORMAL INSPECTION LOG FOR STANCHION DAVIT ASSEMBLY

Model No.: _____ Inspector: _____
 Serial No.: _____ Inspection Date: _____
 Date Made: _____ Disposition: _____

INSP. POINT	DESCRIPTION	QTY/ VMDS	COND. (a)	OVERALL ASSESS.(a)	COMMENTS
METALLIC PARTS					
9	Steel Tube	1			
10	Mounting Bracket	1			
11	Bracket Ball Lock Pin	1			
12	D-ring	2			
13	D-ring Plate	2			
14	Bolt	2			
15	Washer, flat, 1/2" dia.	4			
16	Nut, locking, 1/2"	2			
PLASTIC PARTS					
17	Label	4			

- (a) Optional simplified PASS/FAIL inspection format: Whenever an acceptable condition is found, the entry in the COND. and OVERALL ASSESS. columns may be left blank. Whenever a defective condition is found, enter "FAIL." The inspection may end upon detection of a single defective condition.
- (b) Blank copies of this LOG, with associated CHECKLIST and DIAGRAM, are available from MSA.
 Call Toll Free 1-800-672-2222.

12.6 FORMAL INSPECTION DIAGRAM

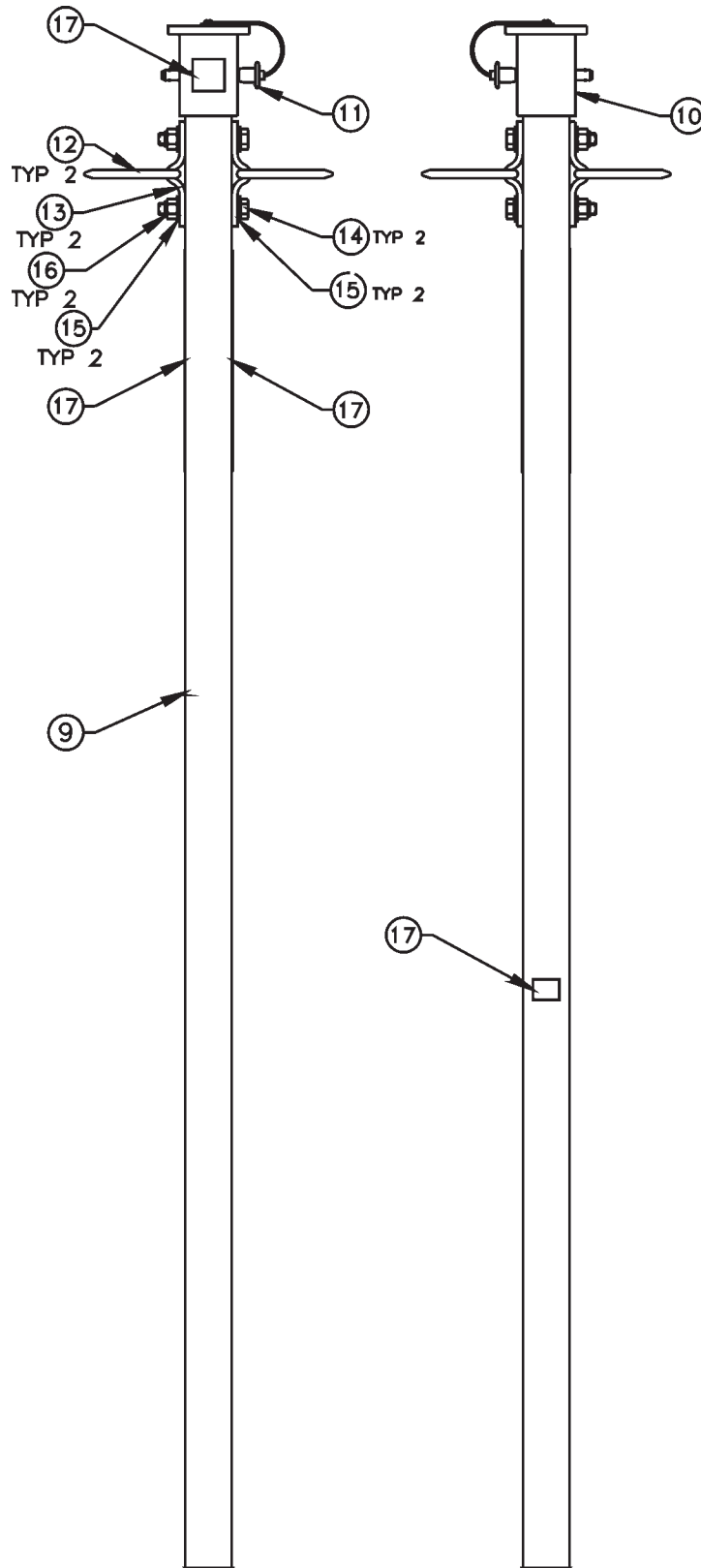

STANCHION DAVIT ASSEMBLY
P/N 506677

12.6 FORMAL INSPECTION DIAGRAM

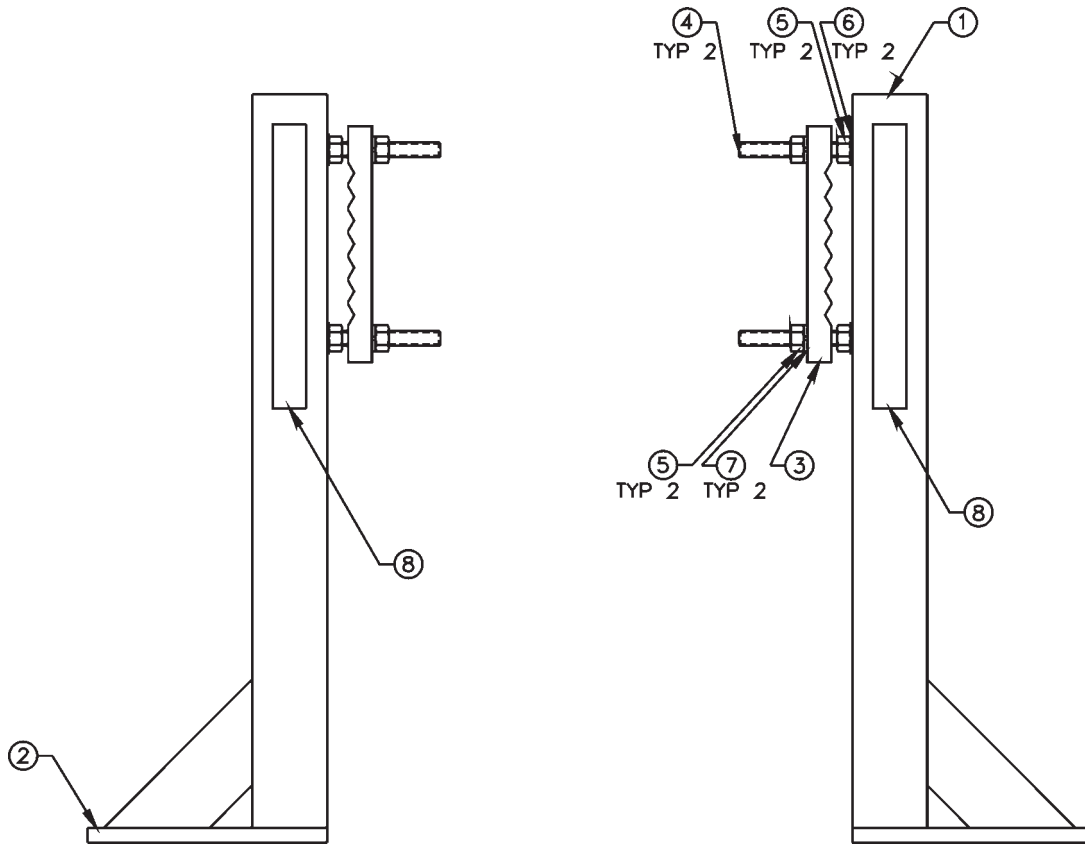

DAVIT MOUNTING RECEPTACLE
P/N 506678

WARRANTY

Express Warranty – MSA warrants that the product furnished is free from mechanical defects or faulty workmanship for a period of one (1) year from first use or eighteen (18) months from date of shipment, whichever occurs first, provided it is maintained and used in accordance with MSA's instructions and/or recommendations. Replacement parts and repairs are warranted for ninety (90) days from the date of repair of the product or sale of the replacement part, whichever occurs first. MSA shall be released from all obligations under this warranty in the event repairs or modifications are made by persons other than its own authorized service personnel or if the warranty claim results from misuse of the product. No agent, employee or representative of MSA may bind MSA to any affirmation, representation or modification of the warranty concerning the goods sold under this contract. MSA makes no warranty concerning components or accessories not manufactured by MSA, but will pass on to the Purchaser all warranties of manufacturers of such components. THIS WARRANTY IS IN LIEU OF ALL OTHER WARRANTIES, EXPRESS, IMPLIED OR STATUTORY, AND IS STRICTLY LIMITED TO THE TERMS HEREOF. MSA SPECIFICALLY DISCLAIMS ANY WARRANTY OF MERCHANTABILITY OR FITNESS FOR A PARTICULAR PURPOSE.

Exclusive Remedy - It is expressly agreed that the Purchaser's sole and exclusive remedy for breach of the above warranty, for any tortious conduct of MSA, or for any other cause of action, shall be the repair and/or replacement, at MSA's option, of any equipment or parts thereof, that after examination by MSA are proven to be defective. Replacement equipment and/or parts will be provided at no cost to the Purchaser, F.O.B. Purchaser's named place of destination. Failure of MSA to successfully repair any nonconforming product shall not cause the remedy established hereby to fail of its essential purpose.

Exclusion of Consequential Damages - Purchaser specifically understands and agrees that under no circumstances will MSA be liable to Purchaser for economic, special, incidental, or consequential damages or losses of any kind whatsoever, including but not limited to, loss of anticipated profits and any other loss caused by reason of the non-operation of the goods. This exclusion is applicable to claims for breach of warranty, tortious conduct or any other cause of action against MSA.

For additional information, please contact the Customer Service Department at 1-800-MSA-2222 (1-800-672-2222).

MSA CORPORATE HEADQUARTERS ■ P.O. BOX 426
PITTSBURGH ■ PA ■ 15230 ■ USA
TEL. 1-800-672-2222 ■ FAX 1-800-967-0398

Dyna Brake®, **Dyna-Glide™**, **Backpacker™ SRL**, **Fallbloc™**, **Dynescape™**, **Dyna-Lock®**, **Dynevac®** and **Pullover™** Harness are trademarks of MSA. U.S. patents and foreign patents cover various aspects of this product.