



## Fall Protection for Telecom Towers





NOW WITH  
ADDITIONAL ADJUSTMENT IN  
TORSO & LEG STRAPS  
FOR INCREASED COMFORT

## TECHNACURV™ TOWER HARNESS

The TechnaCurv Tower Harness throws a curve to the ordinary harness with many new features never before seen in a full body harness:

- Curvilinear Comfort System
- Visco-Elastic Shoulder padding
- Innovative web design
- Secure-Fit buckles
- Sorbtek fabric on shoulder and sub-pelvic pads
- Variable width webbing in the sub-pelvic area



In addition to the features above, the TechnaCurv harness is designed with downward adjusting torso straps on most models to ease adjustment. This is also the first harness on the market that allows you to order exactly the options you want, and only the options you want, through our Assemble-to-Order process. All these features combine to provide you with the most comfortable, versatile, unique, and safe harness available today. All TechnaCurv Tower Harnesses meet ANSI Z359.1, all applicable OSHA regulations, and are CSA certified

**And now, we're making a great harness even better!** You will notice a few changes on your TechnaCurv Harness that will improve the functionality and comfort of the harness. These improvements include:

- + Addition of two Lanyard Clips on every harness, at no additional cost.
- + Addition of webbing length to the torso and leg strap portions of the harness to give you a wider range of adjustment. These additions will provide you with the perfect, most comfortable fit every time you put on your harness.

### THE CURVILINEAR COMFORT SYSTEM

#### FEATURES:

#### Curvilinear Torso Webbing

- This patent-pending process curves the webbing around the neck area to help prevent chafing and discomfort on the neck that can be caused by some standard harnesses.

#### COMBINED WITH

#### Adjustable Y Back D-Locator Pad

- Allows complete adjustment of the back D-ring to provide proper harness fit
- Assists in moving the shoulder webbing away from the neck, providing additional comfort to the user.
- Ribbed web slots in back pad allow for easy back D Ring adjustment.
- A special polymer blend allows for optimal strength and minimal weight, giving you a lighter, more durable harness.

#### TO PROVIDE YOU WITH TOTAL COMFORT!

#### Secure-Fit™ Buckle

- Designed to ease donning, doffing, and adjustment.
- Single hand operation.
- Buckle release tabs move in opposite directions and are recessed inside the outer buckle dimensions to prevent accidental disengagement.
- Positive engagement windows allow you to see that the buckle is properly engaged. No need to try and listen for a "click" on a noisy job site.

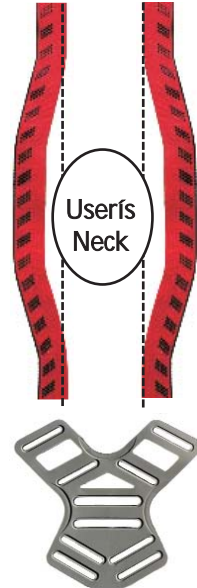

#### Body Belt & Removeable Saddle

- Constructed using a dual durometer pad and Sorbtek fabric for ultimate comfort
- Body Belt includes two side D-rings and two accessory rings
- Removeable Saddle includes two side D-rings
  - Saddle height is adjustable
- D-ring position is adjustable

#### Comfort Ridges

- Provide more air circulation around the padding to keep you cooler.

#### Shoulder Pads with Sorbtek™ Fabric & Visco-Elastic Padding

- A highly breathable, lightweight fabric designed to wick moisture away from the body.
- Developed by NASA, Visco-elastic padding is more comfortable than traditional foam padding.
- Does not have memory and will not break down over time
- Automatically adjusts to every curve of your body

## TechnaCurv Harness Ordering Information

All harnesses listed here are Standard (STD) size. Other sizes are available. All TechnaCurv Tower harnesses include body belt and saddle.

Part No.	TYPE	DESCRIPTION									D-RINGS		
		STYLE		PADDING		CHEST BUCKLE		LEG BUCKLES			Back	Chest	Hip
		Pullover	Vestype	Shoulder	Sub-Pelvic	Secure-Fit	Qwik-Fit	Secure-Fit	Tongue	Qwik-Fit			
10048344	X		X	X	X		X	X			1	1	2
10048346	X	X		X			X		X		1	1	2
10048348	X		X	X			X		X		1	1	2
10048350	X	X					X			X	1	1	2
10048352	X		X				X			X	1	1	2

## FP DIAMOND™ EXPANYARD

The FP Diamond shock absorbing lanyard raises the standard for shock absorbing lanyards with these exciting features:

- Elastic design reduces trip hazards and snag hazards
- 6' Diamond Expanyard contracts to 4.5'
- 10' Diamond Expanyard contracts to 7'
- Durable polyester sheath for increased abrasion and UV resistance
- Keeps fall arrest forces below 900 lbs
- Available in a single or twin-leg configuration
- Highly visible deployment tag
- Pouchless design
  - ➔ More comfortable to wear
  - ➔ Lighter weight
- ATO ordering flexibility allows you to order the exact options, and only the options, you want
- Meets OSHA regulations, ANSI A10.14, ANSI Z359.1, and is CSA certified 

Strong & durable polyester sheath for increased abrasion and UV resistance



Part No. 10045936

Teflon coating to provide water, stain, and mildew resistance.



Swivel Snaphook on the Twin-leg FP Diamond Lanyard prevents the lanyard from tangling during use.



Part No. 10045938

The 6' Diamond Expanyard offers a full 6' range of motion when in use. It contracts to 4.5' when not in use to reduce trip and snag hazards.

## FP Diamond Shock Absorbing Lanyards Ordering Information

Polyester, single piece construction, 6' fixed length, shock absorbing lanyard

Part No.	Harness Connection	Anchorage Connection	Expanyard	Twin-Leg
10045936	HL2000	HL2000	X	
10045938	Swivel HL2000	(2) HL64	X	X
10047290	Swivel HL2000	(2) GL3100	X	X
10053014	LS Snap	LS Snap	X	
10053015	LS Snap	GL3100	X	
10053016	LS Snap	(2) GL3100	X	X

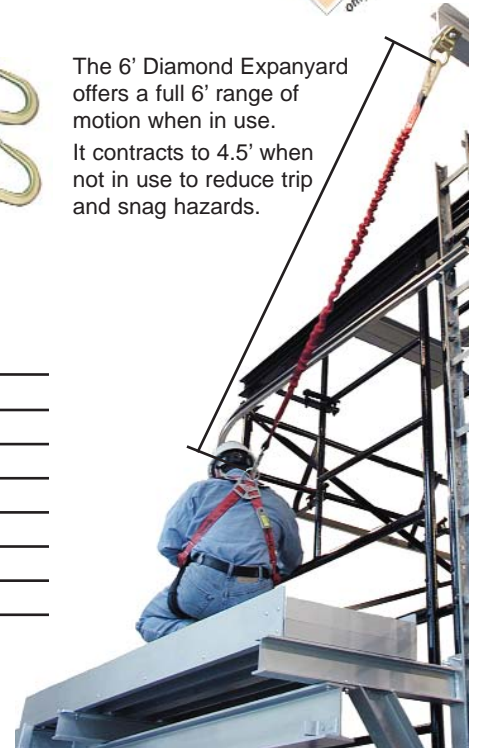

## SHOCK ABSORBING LANYARDS

- Keeps fall arrest forces below ANSI, OSHA, and CSA requirements
- Meets ANSI Z359.1 and applicable OSHA regulations
- Available in single or twin-leg configurations
- SWL60645D, SWL60645B, and SWL70645E meet CSA standards
- Expanyards are designed to stretch to a six-foot length. When relaxed, it stays close to the user's body, reducing the possibility of trips and snags.

### Shock Absorbing Lanyards with 6 ft length, Nylon strap

Part No.	Shock Absorber	Harness Connection	Anchorage Connection	Twin-Leg	Expanyard	Adjustable	1-3/4" Strap	1" Strap
10015877	Dyna-Brake	HL2000	(2) GL3100	X		X		X
SWL60645D	Sure-Stop	Sewn loop	(2) HL64	X	X		X	
SWL60645B	Sure-Stop	Sewn loop	(2) LI Snap	X	X			X
SWL70645E	Sure-Stop	LS Snap	(2) Self-Locking Carabiners	X	X			X



Part No. 10015877



Part No. SWL60645D

## FP5K™ TIE-BACK SHOCK-ABSORBING LANYARD

- Uses the FP5K Carabiner, a new Tie-back lanyard connector
  - ➔ 5000 pound gate strength in any direction allows the FP5K Carabiner to be tied back directly to the lanyard
  - ➔ Unique carabiner body shape helps avoid confusion with standard connectors not designed for tie-back applications
  - ➔ FP5K carabiner design allows for maximum clearance inside the body of the carabiner (1" Gate Opening)
- Available in web or cable version
- Web version utilizes Monster-Edge™ Webbing with 12,000 pound minimum breaking strength
  - ➔ Monster-Edge webbing is designed for increased abrasion resistance
  - ➔ Internal wear indicator consists of two yellow threads that, when visible, alert a user as to when the lanyard should be removed from service due to severe abrasion
- Utilizes the Sure-Stop Shock Absorber to keep fall arrest forces below 900 lbs
- Available in both single and twin leg configurations
- Meets OSHA regulations, ANSI A10.14 & ANSI Z359.1, and is CSA certified.

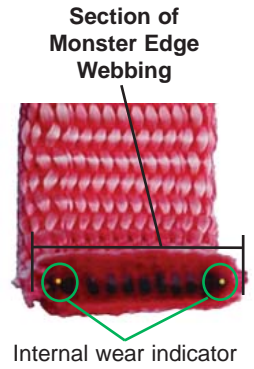

5,000 pound gate strength in any direction.

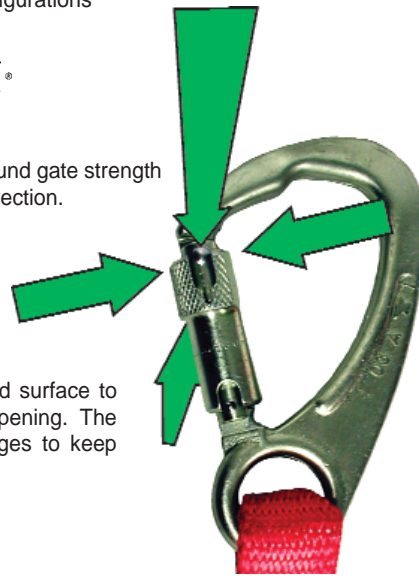

### FP5K CARABINER

The outer side of the gate has a knurled surface to provide a secure grip on the gate when opening. The inner side of the gate has flattened edges to keep lanyard/gate contact at a minimum.



## FP5K Tie-Back Lanyard Ordering Information

Part No.	Description
10047084	FP5K Tie-Back Lanyard, Nylon Web, 6' Adjustable Length, with HL2000 snaphook on one end and FP5K Carabiner on the other end.
10047085	Twin Leg FP5K Tie-Back Lanyard, Nylon Web, 6' Adjustable Length, with HL2000 snaphook in center (attaches to back D-ring) and FP5K Carabiners on each leg.

## SURE-GRAB™ POSITIONING LANYARD

### Sure-Grab Positioning Lanyard Ordering Information

Part No.	CSA Part No.	Description
10030379	SNYR537DH306	Sure-Grab positioning lanyard, manual, closed body, c/w 5/8" x 6' blue Static Kernmantle, chrome locking swivel snaphook, right-handed version*
415957		Rebar strap assembly, Large snaphook with 2.5" (64 mm) gate

\* Also available in left handed version.







## ROPE GRABS

The SVLR78 Sure-Grab device and lifeline is used to provide temporary fall protection on ladders or when climbing vertical structures. The Sure-Grab device moves freely up or down an approved 5/8" (16 mm) diameter lifeline. When sudden downward movement occurs, a camming lever is activated arresting the fall. The device can be installed or removed from the lifeline at any point along its length.

Meets and exceeds ANSI Z359.1 and OSHA standards. Sure-Grab rope grabs are CSA certified.

## Sure-Grab Rope Grab Ordering Information

Part No.	Description
SVLR78LS	Rope grab fall arrester, automatic/manual, open body, c/w 1-3/4" x 12" web lanyard, SHWS31690LS snaphook
SVLR784001LS02	Rope grab fall arrester, automatic/manual, open body, c/w 1-3/4" x 2 ft shock absorber, SHWS31690LS snaphook
SLLPB672060LS	Lifeline, polyester/polypropylene blended, 5/8" x 60 ft. (16mm x 20 m), with SHWS31690LS snaphook on one end
SLLPS672060LS	Lifeline, polysteel green, 5/8" x 60 ft. (16mm x 20 m), with SHWS31690LS snaphook on one end
SRIW1000	5/8" Termination Plate

## SURE-CLIMB™ PERMANENT CABLE SYSTEM

The Sure-Climb Permanent Ladder Cable System is designed to provide fall protection when climbing or descending ladders or vertical structures up to 300' in height. Applications include telecommunications towers, light poles, water towers, hydroelectric towers, stacks, and any other climbable structure. The Sure-Climb permanent system:

- Includes energy-absorbing, galvanized steel top and bottom mounting brackets
- Uses a 5/16" galvanized steel cable
- Incorporates cable guides to minimize cable vibration and wear
- Uses a stainless steel fall arrester (ordered separately)
- Meets all applicable OSHA regulations and ANSI standards
- CSA certified

## Sure-Climb Permanent Cable System Ordering Information

Part No.	Description
SFPLS350050	Sure-Climb System 50 ft (16 m)
SFPLS350100	Sure-Climb System 100 ft (30 m)
SFPLS350200	Sure-Climb System 200 ft (60 m)
10040010	Sure-Climb Slider (Fall Arrester) with Carabiner

Additional Lengths available from 20 ft. up to 300 ft. in 10 ft. increments

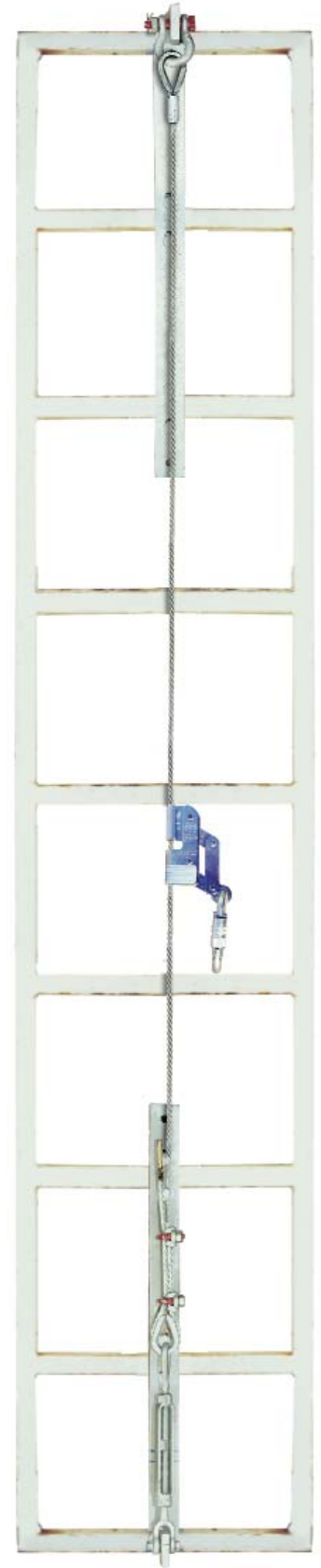

All Sure-Climb systems include: anchor bracket, anchor shackle, cable guides, wire rope clips, turnbuckle, and cable. Fall Arrester must be ordered separately.

## DYNA-GLIDE® CLIMBING PROTECTION SYSTEM

The Dyna-Glide is a rigid rail climbing system that can play an important role in your overall worker safety program.

The Dyna-Glide Climbing Protection Systems are used to prevent and/or arrest falls from heights and also enhance the way a climber is able to perform the necessary work. Our systems can be mounted to already-installed ladders, to corners of lattice towers, and to almost any other suitably strong structure your crew needs to climb. Systems can be constructed to continuously protect climbers – whether they're traveling vertically, horizontally, or around curves, corners or obstacles.

The Dyna-Glide System can be used by more than one person at a time.

### Dyna-Glide Ladder Climbing System Ordering Information

Part No.	CSA Part No.	Description
506270*		Straight Notched Rail, galvanized, standard length 7' 4-3/16"
506273*		Rung Mount Assembly, galvanized
506274		Gated top end stop, stainless steel
506275		Gated bottom end stop, stainless steel
506277	415752	Fall arrester
506280*		Straight unnotched rail, galvanized, standard length 7' 4-3/16"
506282		Mounting base angle corner, galvanized
506283		Mounting angle corner, galvanized
506312		Ungated top end stop, stainless steel
506329*		Rail connector, galvanized
506388		Ladder/Rail Combination (LRC) standoff bracket, galvanized, standard length 7' 4-3/16"
506389		LRC standoff bracket, bottom, galvanized
506390	10006461	LRC, galvanized
506391		LRC side rail connector, galvanized
506392		LRC standoff bracket & assembly, galvanized twin arm and adjustable plate assembly

\* These products also available in stainless steel.



#### Fall Arrester

##### Part No. 506277

- Mechanical locking mechanism to reduce fall distance
- Permits hands-free ascent and descent
- Constructed of aluminum and stainless steel
- Carabiner not included

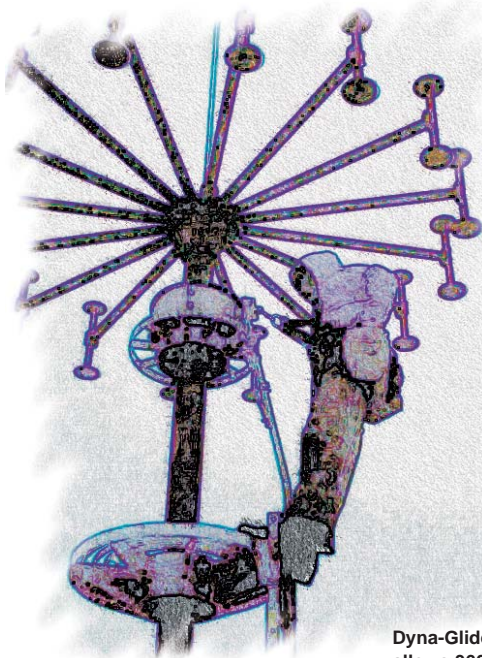

**Dyna-Glide Round-A-Bout System**  
allows 360 degree movement  
while maintaining connection.



#### LRC Combination

##### Part No. 506390

- Rungs incorporate skid resistant surface
- Can be curved or bent for your specific application
- Constructed of galvanized steel
- Standard length: 7' 4-3/16"
- Standard width: 18"

## Telecommunication Tower With Four Structural Steel Angle Legs

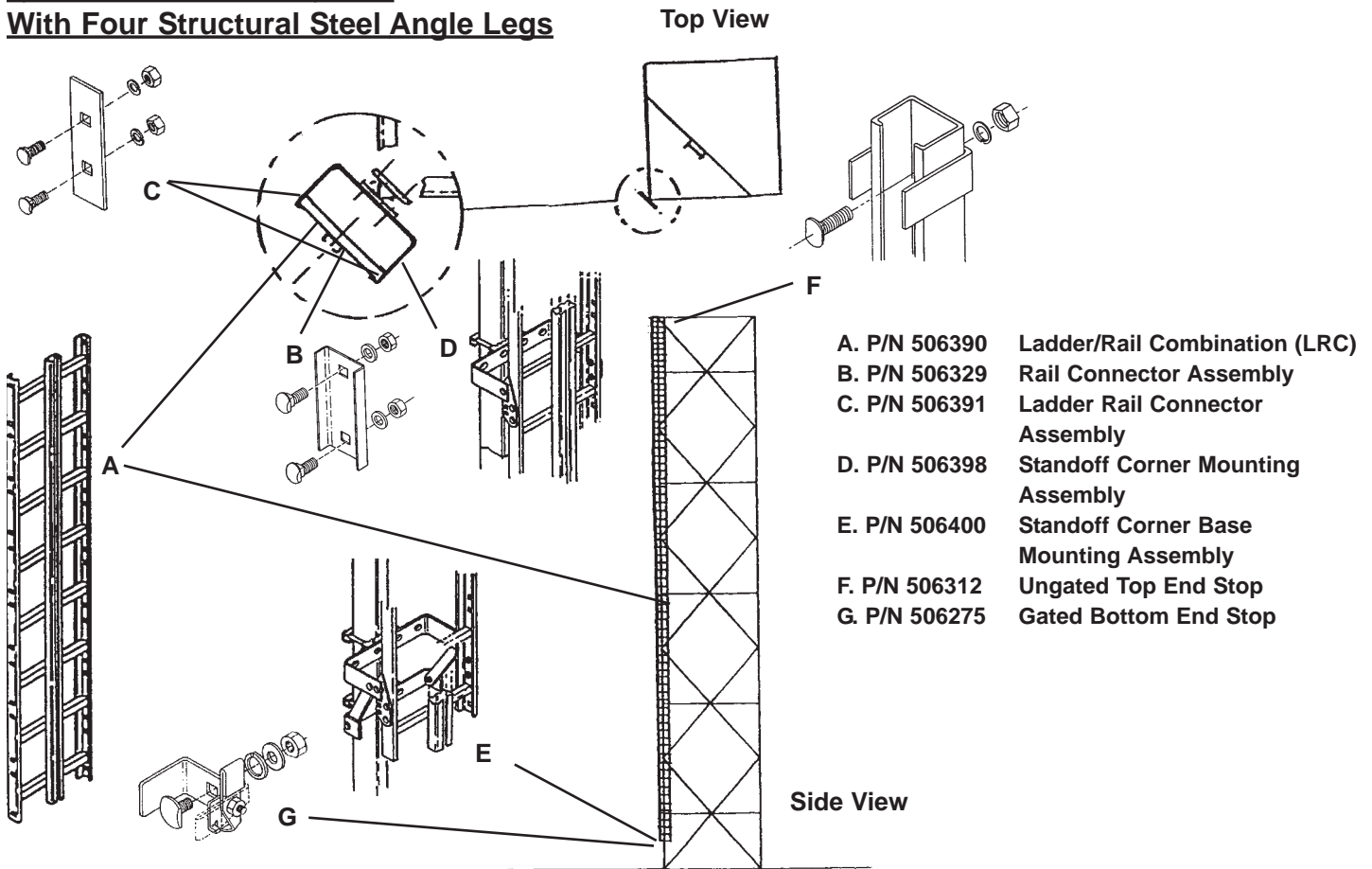

### EMERGENCY RESCUE BAG SYSTEM

The Emergency Rescue Bag System is designed for rescue on electrical and communication towers. Developed for use in restrictive environments, this extremely lightweight system was primarily designed for tower rescue; however, the system can be used to perform rescues on almost any vertical structure. The Emergency Rescue Bag System consists of a pre-rigged lowering System that comes in a variety of lengths. The users of this product must receive training by an approved trainer.

### Emergency Rescue Bag System Ordering Information

Part No.	Description
SRS323020	Emergency Rescue Bag System, 20 ft (6 m), demo unit
SRS323150	Emergency Rescue Bag System, 150 ft (45 m) working length
SRS323300	Emergency Rescue Bag System, 300 ft (90 m) working length

#### PLEASE NOTE:

Due to a 2:1 mechanical advantage, the user should order the Emergency Rescue Bag System with twice the length of rope necessary for their application. For example, the SRS323150 uses 300' of rope to achieve a 150' working length. The maximum system available provides a 400' working length with 800' of rope.

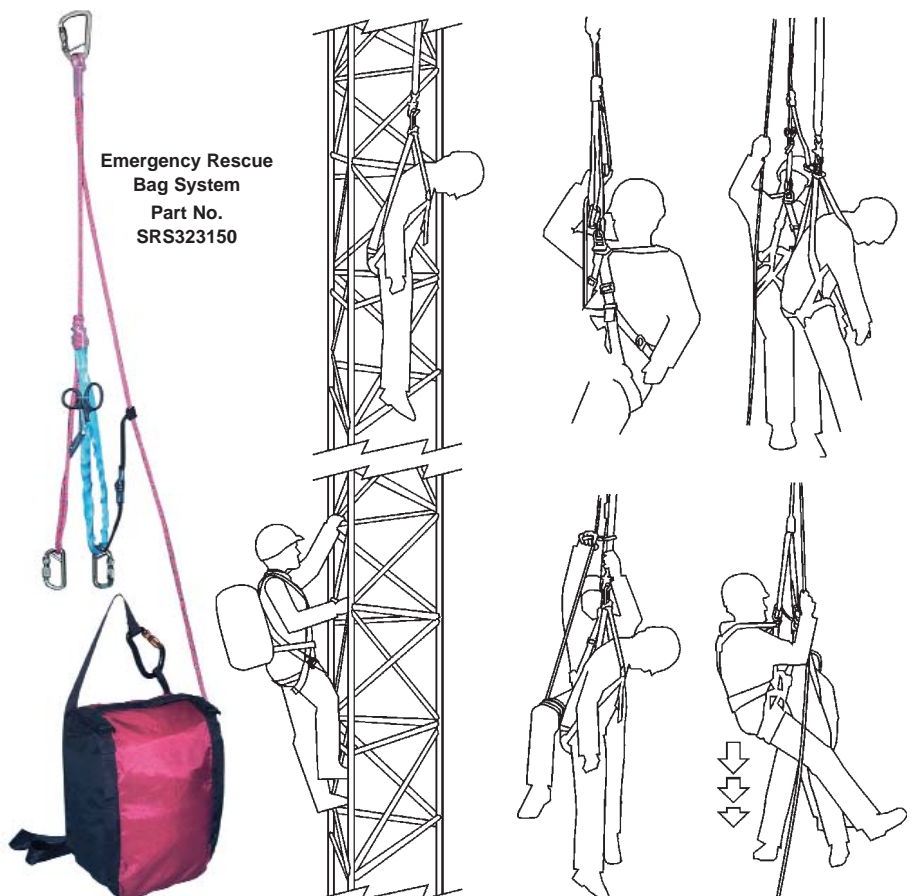



# LEARN FROM THE EXPERTS -

LET US TRAIN YOU  
AT YOUR FACILITY!

## GET READY FOR THE NEW STANDARDS!

Required of ANSI Z359.3: (expected release late 2004 / early 2005)

- New requirements for rescue equipment, including rescue hoists, three-way rescue devices, rope-and-tackle systems and descender devices.
- Expanded training requirements for at-risk workers, Competent Persons and Qualified Persons
- New guidelines for post-fall rescue and retrieval, including more stringent definitions for rescue trainers and rescue team members
- Rescue planning to ensure prompt rescue of fallen workers that reduces the hazard of suspension trauma.

## TOWER CLIMBING SAFETY & RESCUE

### Topics include:

- Selection & application of fall protection systems
- Basic fall protection principles
- Review of applicable, industry-related standards
- Learn and Demonstrate newly developed climbing skills and safe climbing practices
- Courses taught on-site at your location or at one of MSA's training facilities
- Industry specific rescue planning using MSA's own rescue hierarchy of controls
- Courses taught by qualified instructors in a one or two day format

MSA also offers the following Fall Protection training courses:

### FUNDAMENTALS OF SAFETY AT HEIGHTS

### COMPETENT PERSON FOR EQUIPMENT INSPECTION

### SAFETY AT HEIGHTS PROGRAM MANAGEMENT & RESCUE PLANNING

### COMPETENT PERSON FOR SAFETY AT HEIGHTS

## REGISTRATION INFORMATION

We invite you to attend our next training session, which will prove to be a comprehensive and valuable experience. For registration information, please contact the MSA Customer Service Center by phone (1-800-672-2222) or by fax (1-800-967-0398), or log onto our web site at [www.MSAFallProtection.com](http://www.MSAFallProtection.com).



HANDS-ON,  
COMPREHENSIVE  
COURSES

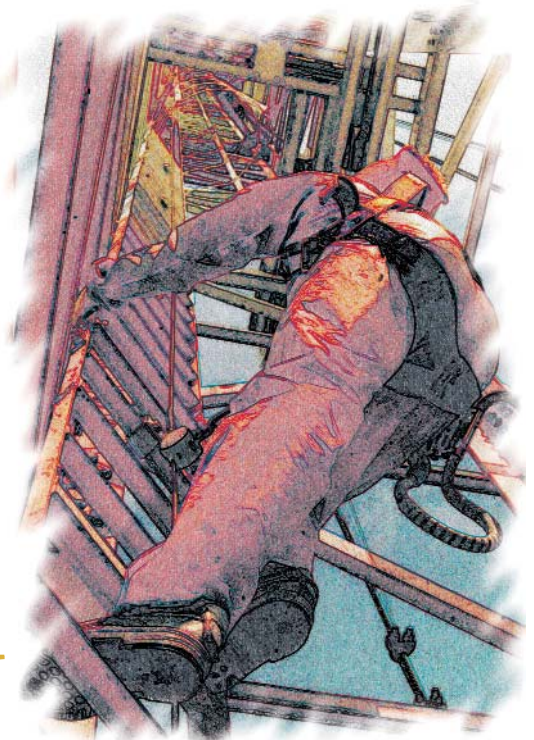

Note: This Bulletin contains only a general description of the products shown. While uses and performance capabilities are described, under no circumstances shall the products be used by untrained or unqualified individuals and not until the product instructions including any warnings or cautions provided have been thoroughly read and understood. Only they contain the complete and detailed information concerning proper use and care of these products.



Corporate Headquarters  
P.O. Box 426, Pittsburgh, PA 15230 USA  
Phone 412-967-3000  
[www.MSAnet.com](http://www.MSAnet.com)  
U.S. Customer Service Center  
Phone 1-800-MSA-2222  
Fax 1-800-967-0398  
MSA Canada  
Phone 1-800-MSA-2222  
Fax 1-800-967-0398  
MSA Mexico  
Phone 52 (2) 1 22 57 30  
Fax 52 (5) 3 59 43 30  
MSA International  
Phone 412-967-3354  
Fax 412-967-3451

Offices and representatives worldwide  
For further information: