

Workman® Harness Product Specifications

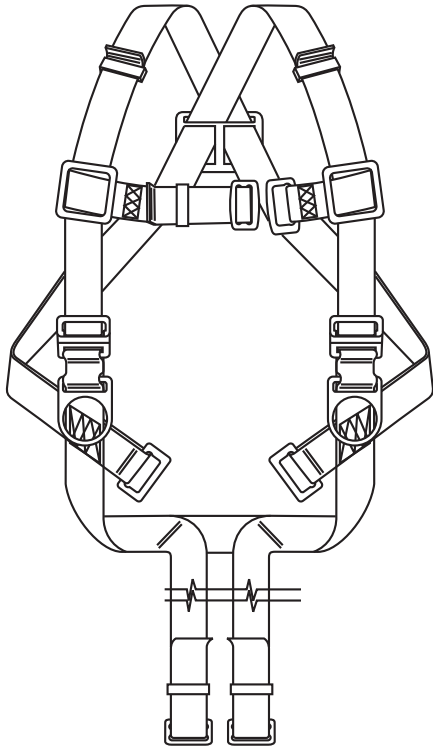

MATERIALS

Web:	1 3/4" (44 mm) nominal width, Polyester
D-Ring:	2 3/8" (56 mm) nominal width Zinc-plated, stamped-alloy steel
Hardware:	Zinc-plated, stamped-alloy steel
Thread:	Polyester Box stitches: 3 cord thread Reinforcement stitches: 5 cord thread
Plastic Parts:	PVC
Labels:	Valeron, NRV

TECHNICAL

Web Minimum Breaking Strength:	6,000 pounds
D-Ring Minimum Breaking Strength:	5,000 pounds Proof-tested to 3,600 pounds
Maximum Capacity:	400 pounds (181 kg)

CERTIFICATION

OSHA:	All applicable standards including 1910.66 and 1926.502
ANSI:	A10.32 and Z359.1-2007
CSA:	Z259.10-M90 classes A and P

Workman® Lanyard Product Specifications

MATERIALS

Lanyard:	
Web:	1" (25 mm) nominal width Polyester 8500 pound minimum breaking strength
Shock Absorber:	
Web:	1 3/4" (44 mm) nominal width Polyester 6000 pound minimum breaking strength
Thread:	Polyester Box stitches: 3 cord thread
Connecting Hardware:	
Snaphook:	Zinc-plated, stamped-alloy steel 100% proof tested to 3600 pounds (16 kN) 5000 pound (22.2 kN) minimum breaking strength 3/4" (19 mm) gate opening
Adjusting hardware:	Zinc-plated, forged-alloy steel 5000 pound (22.2 kN) minimum breaking strength

TECHNICAL

Maximum Capacity:	310 pounds (141 kg) for OSHA; 115kg for CSA Z259.11-05 E4
Minimum Capacity:	99 pounds (45 kg) for OSHA; 45kg for CSA Z259.11-05 E4
Standard Lanyard Length:	6' adjustable
Maximum Arresting Force:	900 pounds (4 kN)

CERTIFICATION

This product meets or exceeds the following standards:

OSHA:	1910.66 and 1926.502
ANSI:	A10.32
CSA:	Z259.11-05 E4

