

Adapter Kit

part no.

91385

48733

for skullgard cap and
welding helmet



For More Information, call 1-800-MSA-2222 or Visit Our Website at www.MSAnet.com

MSA
The Safety Company

MINE SAFETY APPLIANCES COMPANY
PITTSBURGH, PENNSYLVANIA, U.S.A. 15230

TO ASSEMBLE LUGS TO MSA MEDIUM AND LARGE SKULLGARD CAP

1. Select template from kit and follow layout instructions for location of right hand (R.H.) lug on cap.
2. Support shell under area for new holes.
3. Mark holes as located on template with center punch and remove template.
4. Drill (2) two 5/32" diameter holes.
5. Attach lug to right side of cap with two self-tapping screws and backing plate, items 6, 7, and 8 (Figure 1). Be sure foam pad is attached to lug before installation. Do not use bracket without foam pad.
6. Repeat above procedure for left side (Figure 2).

WARNING

Use of this kit on an ANSI Z89.1 (latest Edition), Class E cap (formerly Class B) and Class G cap (formerly Class A) reduces the electrical insulation properties to that of a Class C cap. Use of this kit on a Class C cap does not affect the ANSI Class. Apply Class C sticker provided with kit above existing sticker provided with cap and cross out reference to Class on existing sticker. Failure to install the sticker as described above can misrepresent the electrical protection and result in personal injury or death.

TO ASSEMBLE METAL INSTANT RELEASE BRACKET ASSEMBLY AND FRICTION JOINT ASSEMBLY TO WELDING HELMET

1. Remove existing friction assembly or headgear from welding helmet.
2. Assemble instant release bracket assembly item 5 & friction joint assembly items 1, 2, 3, 4, 10 and 11 to welding helmet as per Figure 1. (Be sure to use correct Left (L) and Right (R) instant release bracket.)

Note: Look closely at the internal tooth lock washer; be sure the lock washer has the smooth side down over the threaded stud on the bracket. The beveled edge should be on top.

3. The adjustable stop (Item 9) is assembled to the left side of the welding helmet in place of the large washer (Item 10) per Figure 2.
4. Assemble welding helmet to cap by inserting instant release bracket assembly posts into lugs on cap.
5. Adjust tension to suit with friction joint knob.

Figure 1 - Right Side

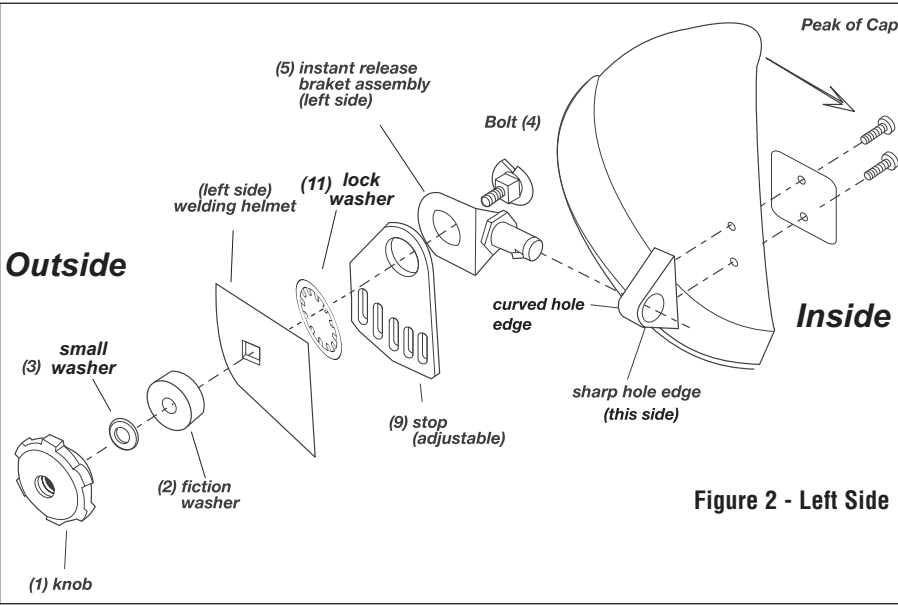
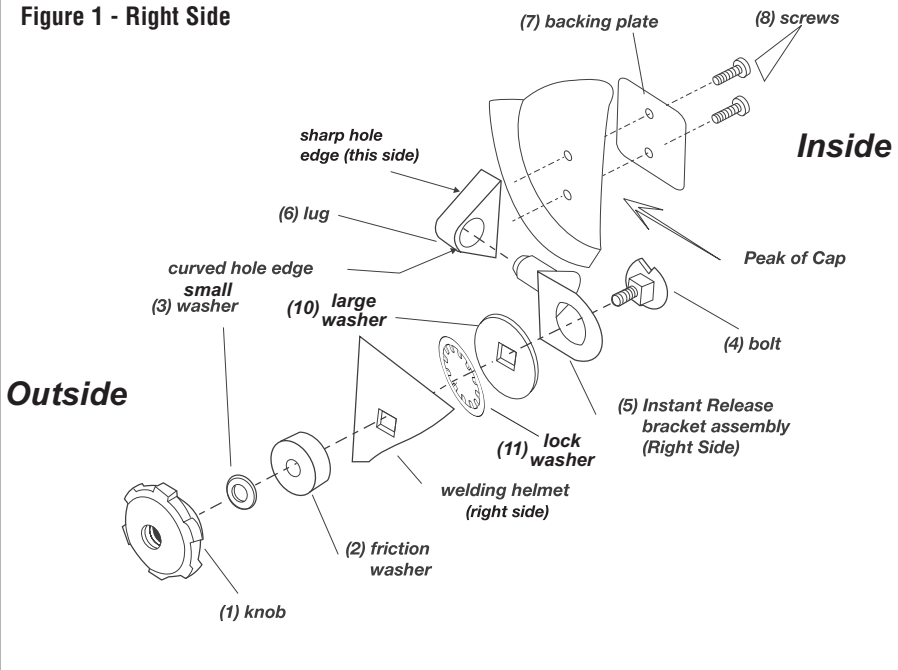

Figure 2 - Left Side

Normal Bracket Position				
Skullgard® Cap with Full Curve Welding Helmet and Metal Instant Release				
MSA Cap	Cap Brim Forward	Cap Brim Backward	Half Mask Respirator with Flexi-filter® cartridges	Half Mask Respirator with single cartridges
Medium	No	Yes	Yes	Yes
Large	No	Yes	Yes	Yes
Skullgard® Cap with Full Curve Welding Helmet and *Plastic Instant Release				
MSA Cap	Cap Brim Forward	Cap Brim Backward	Half Mask Respirator with Flexi-filter® cartridges	Half Mask Respirator with single cartridges
Medium	Yes	Yes	Yes	Yes
Large	Yes	Yes	Yes	Yes
Skullgard® Cap with Slim Line Welding Helmet and Metal Instant Release				
MSA Cap	Cap Brim Forward	Cap Brim Backward	Half Mask Respirator with Flexi-filter® cartridges	Half Mask Respirator with single cartridges
Medium	No	Yes	Yes	Yes
Large	No	Yes	Yes	Yes
Skullgard® Cap with Full Slim Line Helmet and *Plastic Instant Release				
MSA Cap	Cap Brim Forward	Cap Brim Backward	Half Mask Respirator with Flexi-filter® cartridges	Half Mask Respirator with single cartridges
Medium	Yes	Yes	Yes	Yes
Large	Yes	Yes	Yes	Yes

***Plastic instant release kit #10039111 sold separately and not included with this kit.**