

MSA Ultima® IR Retrofit Kit Instruction Sheet

⚠ WARNINGS

This Retrofit Kit cannot be used for intrinsically safe applications.

Modifying the Ultima product affects hazardous location approvals. Upgrading this product must be assessed by individuals with application knowledge of hazardous location requirements (Refer to NEC Article 500 requirements).

Remove power before servicing the Ultima Monitor. Before removing the cover of an explosion-proof Ultima Gas Monitor, verify the surrounding area does not contain a flammable mixture of combustible gas and air, since a source of ignition is exposed; otherwise, an explosion may occur if a metal object contacts the circuitry and produces sparks.

Use correct electrostatic (ESD) practices when performing work on ESD-sensitive devices.

Failure to comply with these warnings can result in serious personal injury or death.

NOTE: Check the current revision of the Interface/Analog PC board (middle board - P/N 804914). If this board is not rev. 4 or higher, it must be replaced, since boards earlier than revision 4 will not work with the Retrofit Kit. An error 8 message will appear on the screen.

NOTE: This Retrofit Kit is designed to convert U.S. installations of Ultima Catalytic Combustible Monitors to Infrared Combustible Monitors only.

NOTE: For Network Ultima Monitors, contact network-experienced MSA Service personnel for Network Installation Tools.

1. Identify and clean the approval markings (see examples in FIGURE 1).
 - a. Check for the main Housing Nameplate on the flat side of the enclosure.
 - b. Check the main housing for the Division 2 adhesive label on the side of the enclosure.
 - c. Check the Remote Housing (if applicable) on the enclosure lid.
 - d. Check the Remote Housing for a Division 2 adhesive label on the side of the enclosure.

If the metallic Approvals Nameplate includes an MET logo, the Intrinsic Safety portion of the label must be permanently obliterated. Use the label cover in the Kit. If no logo is shown, no obliterating is necessary. If any adhesive MET Class 1, Division 2 Label exists, it must be obliterated using the blanking label cover. Apply label covers as shown in FIGURE 1.

2. Prior to servicing the product, read and understand all instructions and warnings. Product servicing must be performed by knowledgeable service individuals. Installation of this Retrofit Kit can be scheduled by calling 1-800-MSA-INST (1-800-672-4678).
3. Remove the explosion-proof cover.
4. Remove the two #6-32 X 1 lg. screws attaching the Display (top) printed circuit board (FIGURE 2).

NOTE: LABELS ARE SIZED FOR FIT. CHOOSE PROPER LABEL

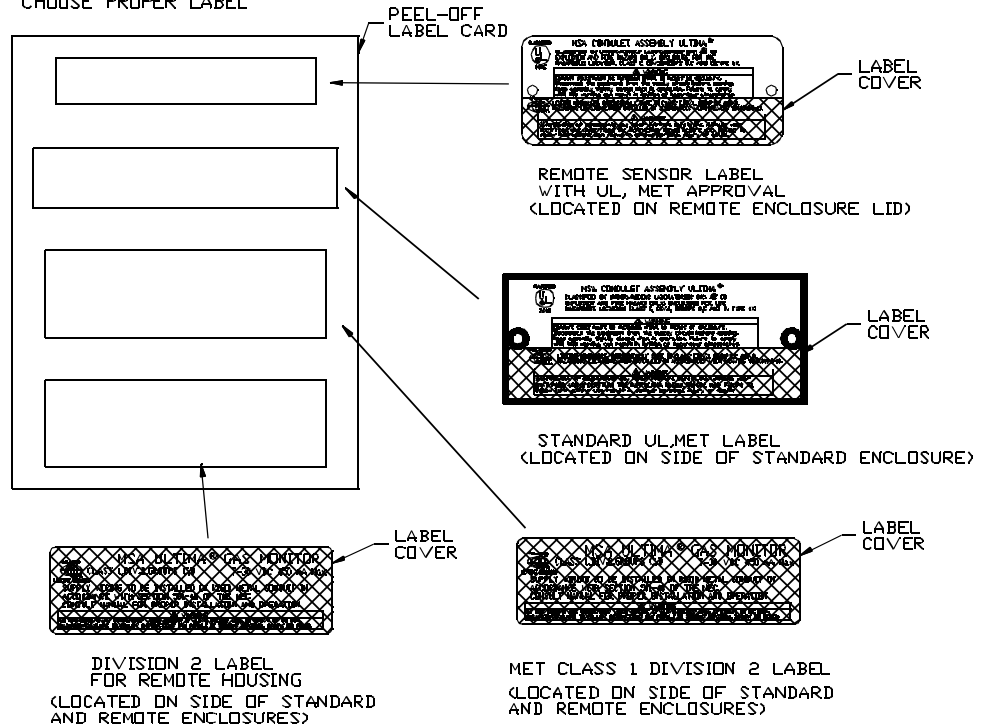

Figure 1. Label Details

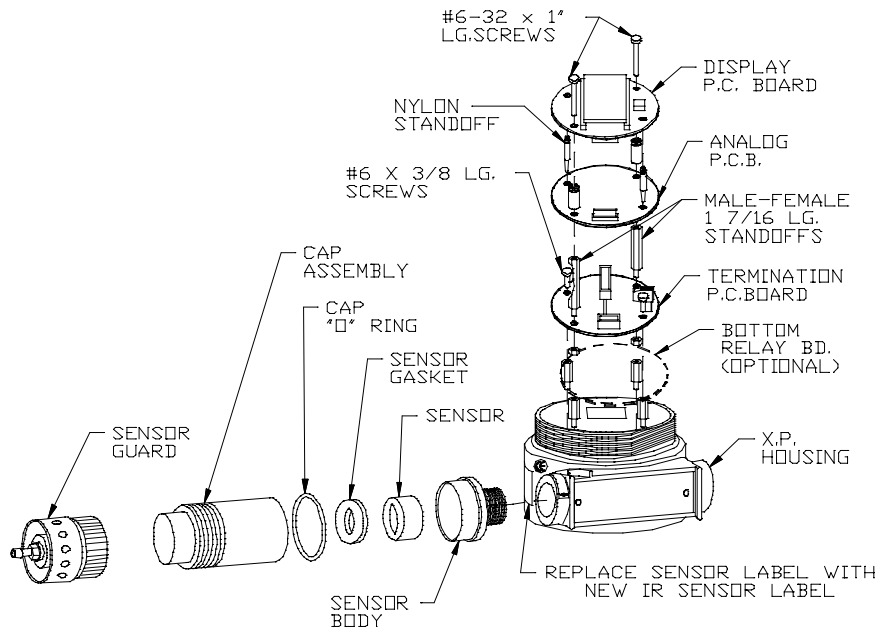

Figure 2. Exploded View

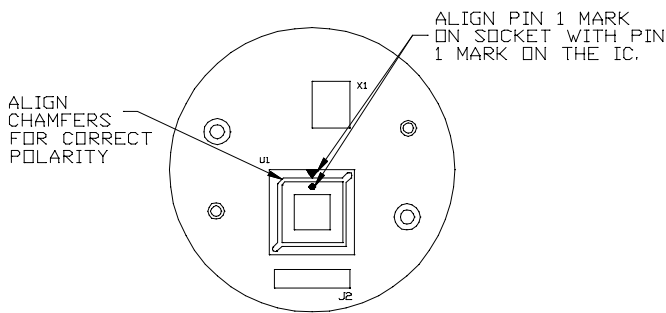

Figure 3. Rear Side of Display Board

5. Lift the Display and Analog/Network printed circuit boards from the Termination printed circuit board socket.
6. Separate the Display printed circuit board from the Analog/Network printed circuit board by cutting off the locking ramps on the two nylon standoffs (new standoffs are supplied in the Retrofit Kit). For Network Digital Ultima Monitors, replace the Analog/Network printed circuit board with the one provided in the Kit [P/N 710323 (rev. 4 or higher)].
7. Using the Retrofit Kit Chip Extractor Tool (provided in the Kit), remove the programmed Microcomputer Chip from the Display board. Replace with Chip (P/N 10016200), observing Chip polarity (FIGURE 3).
8. Cover the Display board Part Number Label by using one of the labels provided in the Kit (FIGURE 5).
9. Using the new nylon standoffs, re-attach the Display board to the Analog/Network board (FIGURE 2).
10. Unplug the sensor and power connections and remove the #6-32 X 3/8 lg. Screws.
11. Remove the Termination board and transfer the 1 7/16 lg. standoffs to the new Termination board.
12. Using the #6-32 X 3/8 lg. screws, install the new Termination board.
13. Remove the Catalytic Sensor and Optional Union, if used.
14. Install the Sensor Body, Sensor, Sensor Gasket, Cap Assembly, "O" Ring and Sensorgard.
 - Sensor Gasket and Cap Assembly should be installed while the unit is in a vertical position to ensure the Sensor Gasket remains flat in the Cap Assembly.
 - When tightening the sensor body to the enclosure, completely tighten threads into the enclosure to ensure a minimum five-thread engagement forms an explosion-proof fit (FIGURE 2).
15. Connect Power and Sensor connections to the Termination board.
 - Sensor connects to J4 on Termination board.
16. Using the #6-32 screws, install the top two printed circuit boards.
17. Install the explosion-proof cover, power the unit and perform initial calibration.
18. Remove sensor label from housing and install new IR sensor label.

Remote Sensor (if applicable)

1. Remove the explosion-proof cover.
2. Remove the two #6-32 X 3/8 lg. screws attaching the Terminal Block and Bracket Assembly to the Housing.

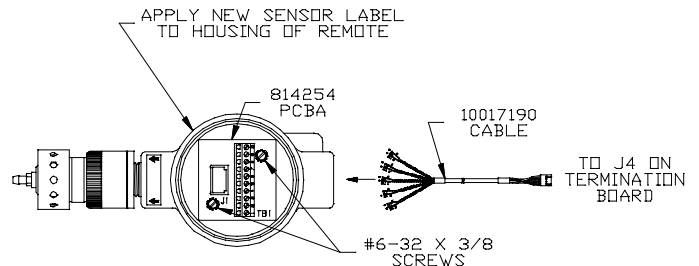

Figure 4. Remote Sensor

DISPLAY LABEL P/N SELECTION		
PART NO.	DISPLAY TYPE	GAS
10016844	NETWORK	METHANE
10016981	3 WIRE MUX	
10016982	3 WIRE FREQ.	
10016983	3 WIRE CURRENT	
10016984	NETWORK	NON METHANE
10016985	3 WIRE MUX	
10016986	3 WIRE FREQ.	
10016987	3 WIRE CURRENT	

Figure 5. Display Label P/N Selection

3. Disconnect wires from the Terminal Block and remove the Terminal Block and Bracket from the Housing.
4. Remove Catalytic Sensor and Optional Union, if used.
5. Install the Sensor Body, Sensor, Sensor Gasket, Cap Assembly, "O" Ring and Sensorgard.
 - Sensor Gasket and Cap Assembly should be installed while the unit is in a vertical position to ensure the Sensor Gasket remains flat in the Cap Assembly.
 - When tightening the sensor body to the enclosure, completely tighten threads into the enclosure to ensure a minimum five-thread engagement forms an explosion-proof fit (FIGURE 4).
6. Using the #6-32 X 3/8 lg. screws and standoffs supplied, install Printed Circuit Board (P/N 814254).
7. Install Power Cable (P/N 10017190).
 - Wire cable to the printed circuit board Terminal Block, noting the corresponding tags on the Cable [(FIGURE 4); also see Instruction Manual (P/N 813161) - Chapter 1, "Electrical Connections for the Ultima Remote Sensor Module"].
 - Cable may be trimmed to appropriate length.
 - Install cable connector into Termination board connector (J4) in the Ultima main housing.
8. Plug Sensor Body Connector into J1 on the printed circuit board.
9. Install explosion-proof cover.
10. Power the unit and perform initial calibration.
11. Apply new IR sensor label to housing.