



Ultima[®] X Gas Monitors with X³[®] Technology

Instruction Manual Addendum

WARNING

THIS MANUAL MUST BE CAREFULLY READ BY ALL INDIVIDUALS WHO HAVE OR WILL HAVE THE RESPONSIBILITY FOR USING OR SERVICING THE PRODUCT. Like any piece of complex equipment, this instrument will perform as designed only if it is used and serviced in accordance with the manufacturer's instructions. OTHERWISE, IT COULD FAIL TO PERFORM AS DESIGNED AND PERSONS WHO RELY ON THIS PRODUCT FOR THEIR SAFETY COULD SUSTAIN SEVERE PERSONAL INJURY OR DEATH.

The warranties made by Mine Safety Appliances Company with respect to the product are voided if the product is not used and serviced in accordance with the instructions in this manual. Please protect yourself and others by following them. We encourage our customers to write or call regarding this equipment prior to use or for any additional information relative to use or repairs.

In North America, to contact your nearest stocking location, dial toll-free 1-800-MSA-INST
To contact MSA International, dial 1-412-967-3354

© MINE SAFETY APPLIANCES COMPANY 2006 - All Rights Reserved

This manual is available on the internet at www.msanet.com

Manufactured by

MSA NORTH AMERICA

P.O. Box 427, Pittsburgh, Pennsylvania 15230

(L) Rev 3

10060413

Table of Contents

Section 1, Typical ModBUS Network

Topography (FIGURE 1-1).1-2

Sensors	1-2
Wiring	1-2
Power	1-2
RS485 Communications	1-2
Transmitter Sensor Distance (FIGURE 1-3)	1-2
Figure 1-1. Typical ModBUS Network Topography .1-3	
Table 1-1. Maximum Power Cable Length	1-4
Table 1-2. Transmitter Power Consumption (7-30 VDC Supply)	1-4
Table 1-3. Remote Sensor Power Consumption (AC or DC Operation)	1-4
Figure 1-2. Typical Communications Wiring Scheme	1-5
Figure 1-3. Signal-Boost Sensor Diagram	1-6

Section 2, Typical Communication Cable

Wiring for Signal Boost (FIGURE 2-1)2-1

Operation	2-1
Display:	2-1
Relays:	2-1
Figure 2-1. Typical Communication Cable Wiring for Signal Boost Option	2-2
Figure 2-2. Sensor Display Screens	2-3
Sensor:	2-4
Alarm Status Screen	2-4
Table 2-1. Status Indication Codes	2-5
Figure 2-3. Alarm Status Screen	2-5
Ultima X Controller or Ultima X Calibrator:	2-6
Calibration	2-6
ModBUS Communications	2-7
Figure 2-4. Push-button Wiring	2-7
▲ WARNING	2-7

Section 3, ModBUS	3-1
ModBUS Addressing	3-1
Table 3-1. Supported ModBUS Function Codes	3-1
Table 3-2. ModBUS Memory Map Overview	3-2
ModBUS Base Address (Read/Write)	3-2
Table 3-3. ModBUS Bas Address (Read/Write)	3-2
Table 3-4. ModBUS Factory Configuration Data (Read Only)	3-3
Table 3-5. ModBUS User Configuration Data (Read/Write)	3-4
Table 3-6. Alarm Function Codes - Word 1 (Read/Write at Address Base+137)	3-5
Table 3-7. Alarm Function Codes - Word 2 (Read/Write at Address Base+138)	3-5
Table 3-8. ModBUS Device Status (Read only)	3-6
Table 3-9. ModBUS General Status Bits (Read Only at address Base+201)	3-8
Table 3-10. ModBUS Fault Status Bits (Read Only at address Base+202)	3-8
Table 3-11. Control Words (Read/Write)	3-9
Table 3-12. ModBUS Command Word 1 (Read at address Base+301/Write Coils 1 through 16)	3-9
Table 3-13. ModBUS Command Word 2 (Read at address Base+302/Write Coils 17 through 32)	3-10
Table 3-14. Sensor Type	3-10
Table 3-15. Sensor Engineering Units	3-11
Table 3-16. Information Flags Word #1 – (Read at address Base+254)	3-12
Table 3-17. Information Flags Word #2 (Read at address Base+255)	3-12
Table 3-18. Information Flags Word #3 (Read at address Base+256)	3-13
Table 3-19. Information Flags Word #4 (Read at address Base+257)	3-13
Table 3-20. Alternate Gas Readings (Read/Write at address Base+258 to Base+260)	3-14

**This is an Addendum to the Ultima/Ultima X
Instruction Manual (P/N 10036101)
for use with the Ultima X ModBUS X³ Transmitter.**

Section 1, Typical ModBUS Network Topography (FIGURE 1-1).

As part of the CSA certification, it was verified that the modbus communication functions of this gas detection instrument do not adversely affect the gas detection operation and functions of the instrument. This Certification, however, does not include or imply certification of the modbus communication function of this gas instrument.

Sensors

- A network can consist of up to 31 monitors.
- Each monitor can support up to three sensors.
- Total number of sensors is 93.

Wiring

Power

- Maximum power cable length depends on sensor configuration and wire gauge (TABLES 1-1, 1-2 and 1-3).

RS485 Communications

- Three-wire cable, 22 AWG is labeled:
 - A = Transmit + / Receive +
 - B = Transmit - / Receive -
 - C = Common
- Typical Communications Wiring Scheme (see FIGURE 1-2)
- Maximum RS-485 communications cable length:
 - Trunk: 3000 feet
 - Branch: 60 feet
- Use line termination devices to match communication line characteristics (typically 120 Ohms).

Transmitter Sensor Distance (FIGURE 1-3)

- Maximum transmitter-sensor distance is normally 100 feet.
- The distance is extended to 3000 feet if the signal boost option is installed.
 - This option requires the sensor to be locally powered.
 - It is possible to selectively use this feature on a per-sensor basis.

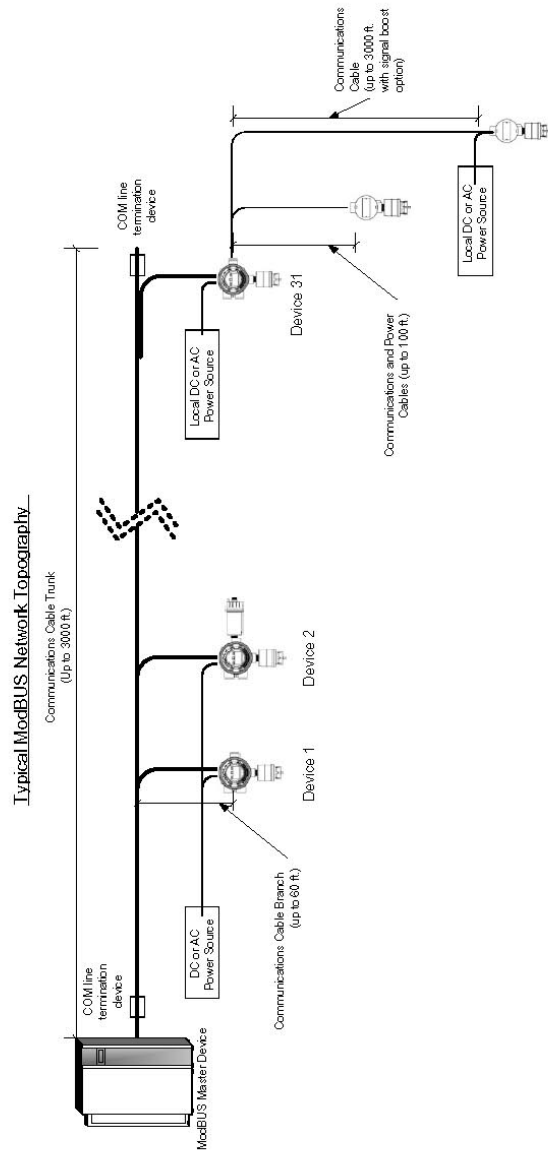

Figure 1-1. Typical ModBUS Network Topography

Table 1-1. Maximum Power Cable Length

CONFIGURATION			MAXIMUM POWER CABLE LENGTH (IN FEET) (WITH NOMINAL 24-VDC TRANSMITTER SUPPLY)					
CATALYTIC	XIR	E-CHEM	16 AWG CABLE [4.2 OHM PER 1K FT.]		14 AWG [2.6 OHM PER 1K FT.]		12 AWG [1.8 OHM PER 1K FT.]	
			NO RELAYS-	RELAY OPTION-	NO RELAYS	RELAY OPTION	NO RELAYS	RELAY OPTION
0	0	3	4500	3500	7500	5500	10,000	7,500
0	2	1	2000	1500	2750	2500	4,000	3,500
0	1	2	3000	2250	4500	3500	6,250	5,000
1	0	2	3500	2750	5500	4250	7,500	6,000
1	1	1	2000	1500	2750	2500	4,000	3,500
2	0	1	2500	1850	3500	3000	5,000	4,000
3	0	0	2000	1500	2750	2500	3,750	3,500

Daisy chaining power to multiple sensors is not recommended.

Table 1-2. Transmitter Power Consumption (7-30 VDC Supply)

CONFIGURATION			MAX. POWER CONSUMPTION WITH RELAYS CLOSED	MAX. POWER CONSUMPTION WITH RELAYS OPEN
CATALYTIC	XIR*	E-CHEM*		
0	0	3	2.5 W	1.5W
0	2	1	9.5 W	8.5W
0	1	2	7.0 W	6.0 W
1	0	2	6.0 W	5.0 W
1	1	1	6.5 W	5.5 W
2	0	1	8.0 W	7.0 W
3	0	0	10.0 W	9.0 W

*Combinations shown represent maximum loads that may be powered from one transmitter without remote power.

NOTE: Only use single catalytic or XIR sensor configuration with 7 W power supply.

If at least one sensor is remote with signal boost or has remote power, any combination is available.

Recommended power supply selection is for operation not to exceed 65% of capacity.

See Installation Outline Drawings for details.

**Table 1-3.
Remote Sensor Power Consumption (AC or DC Operation)**

SENSOR TYPE	MAXIMUM POWER CONSUMPTION
Catalytic*	4.5 W
XIR*	5.0 W
E-Chem	1.5 W

*The input for the 240 VAC Remote XIR and XE Sensors shall be additionally limited to 3.5 A.

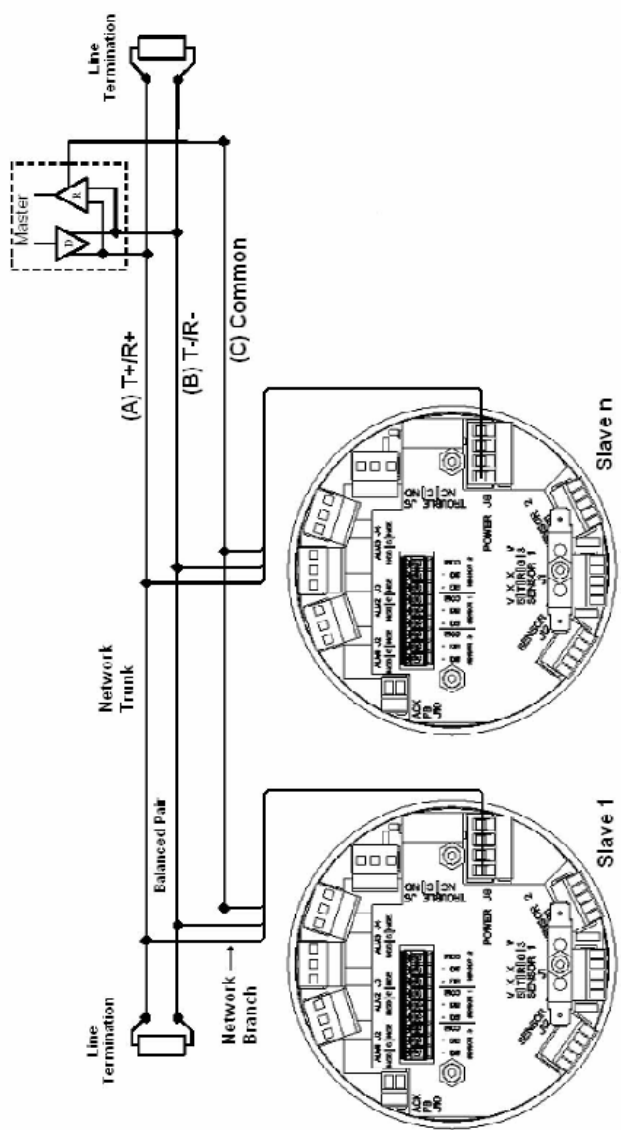

Figure 1-2. Typical Communications Wiring Scheme

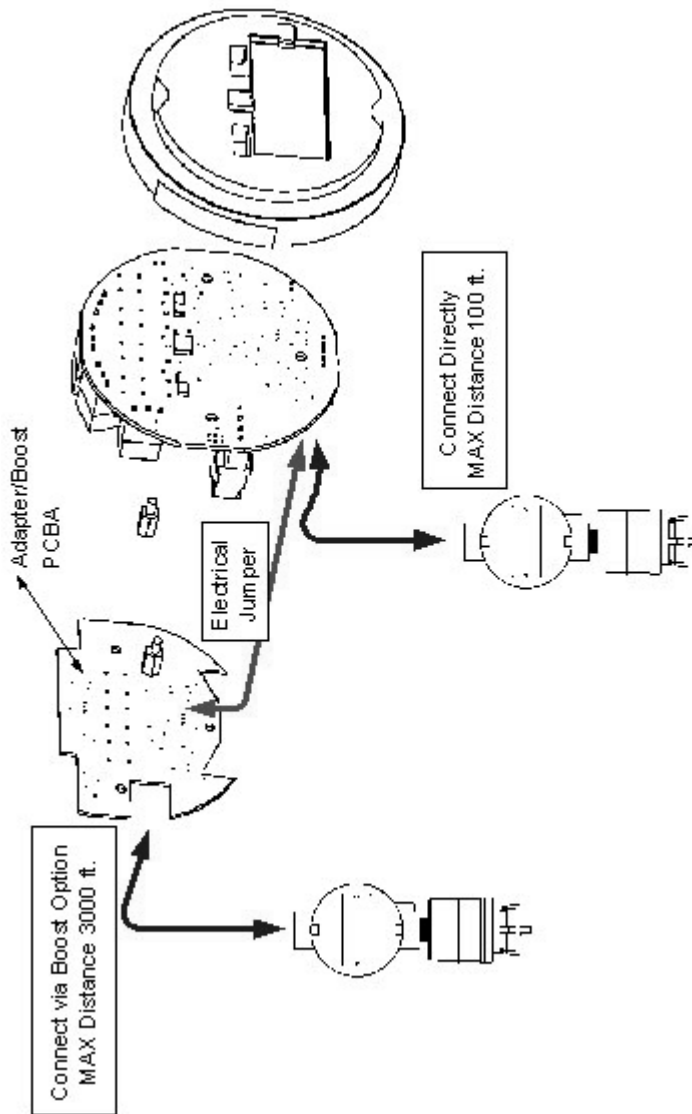

Figure 1-3. Signal-Boost Sensor Diagram

Section 2, Typical Communication Cable Wiring for Signal Boost (FIGURE 2-1)

Operation

Display:

- Displays sensor type and gas level for each sensors
- Cycles through the sensors
- Sensor number graphic identifies sensor number (see FIGURE 2-2)
- Latches on an Alarm or Fault condition and requires user acknowledgment prior to resuming cycling
- If multiple conditions exist, reveals the subsequent alarm/fault condition when one condition is acknowledged
- Resumes cycling through display screens when all conditions are acknowledged.
- Alarm and fault conditions are indicated by alarm and the corresponding number of the alarm level(s) that are activated

Relays:

- Gas processing and alarm activation continues even when a display is locked on a screen
- Are common to all sensors by default
- Can be assigned specifically to a sensor by enabling only one level of alarm for each sensor
 - This may be accomplished through an Ultima X Controller (see Section 2, "Calibration") consistent with the existing Ultima X procedures or through a ModBUS controller
- Form C contacts, 5 A resistive, 30 VDC, 250 VAC
- May be configured as
 - Normally energized/de-energized
 - Increasing/decreasing level alarm
 - Latching/non-latching

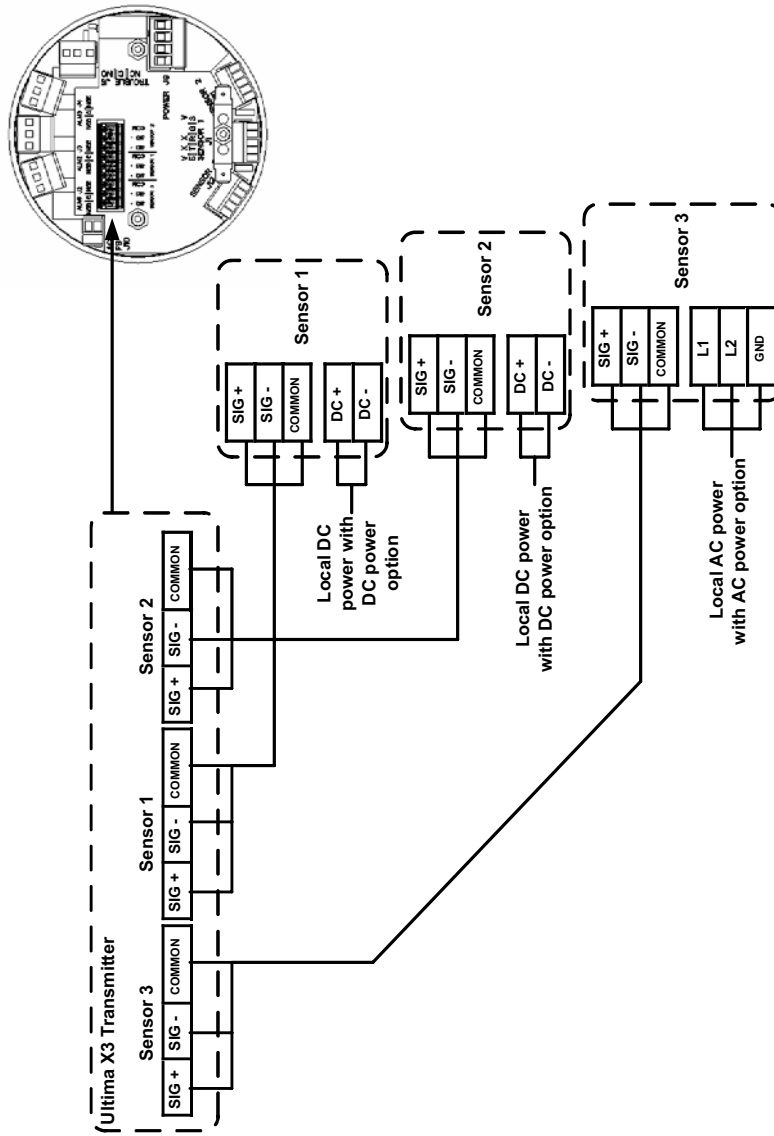

Figure 2-1. Typical Communication Cable Wiring for Signal Boost Option

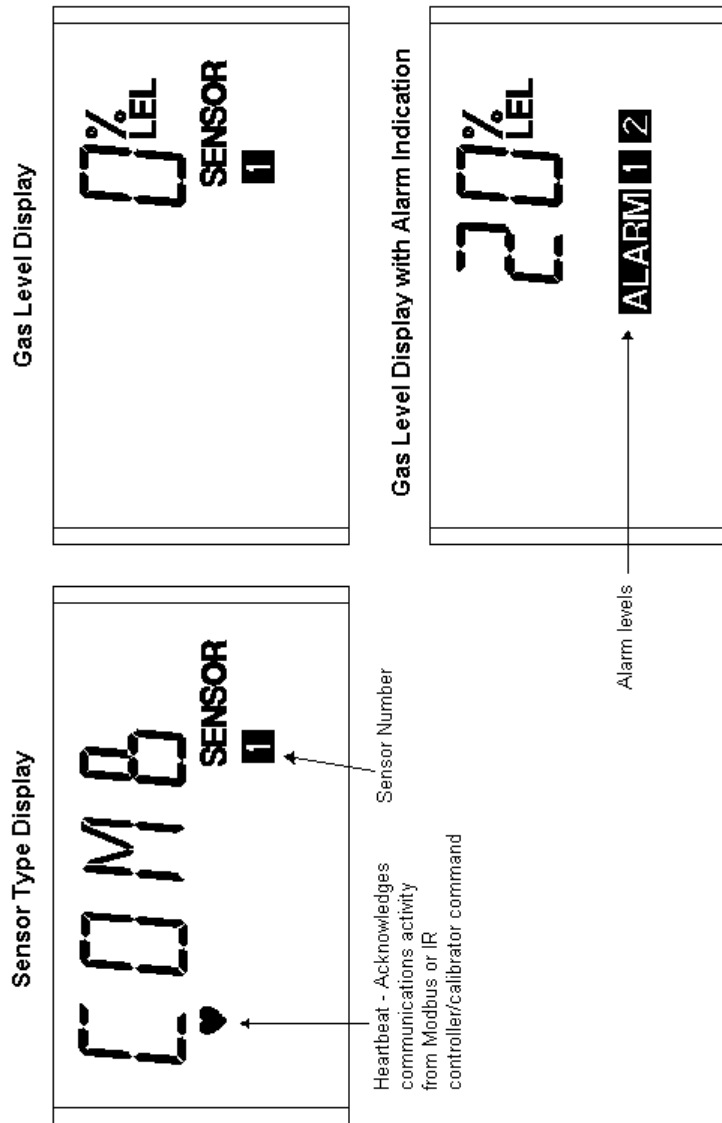

Figure 2-2. Sensor Display Screens

Sensor:

- Automatically recognized when connected to a transmitter
- When removed, causes a "Sensor Missing" fault; this can be corrected by:
 - Reconnecting a sensor to that position or
 - Manually taking the sensor 'off-line' via:
 - Ultima X Controller, by sending a sensor disable command
 - ModBUS command write to a control register.
- A missing sensor or unused sensor position returns a gas value of -99.9 in response to a ModBUS request for gas level value starting at address base +207.

Alarm Status Screen

(FIGURE 2-3)

In the North American version of the Ultima X with X3 Technology, a screen will appear when a combustible sensor crosses 50%, 60% or 90% of the full-scale range.

- This screen:
 - will override all sensor data or fault screens and will clear when all sensors are below 50% of scale.
 - can be acknowledged by the operator; the:
 - instrument will go back to normal display operation until the sensor or any other sensor crosses 50%, 60% or 90% of scale
 - normal operation status screen will display again.
 - can be acknowledged through the:
 - Ultima X Controller
 - Pushbutton or
 - MODBUS interface.

NOTE: All IR inputs will be functional and appropriate display screens will display for the received IR message.

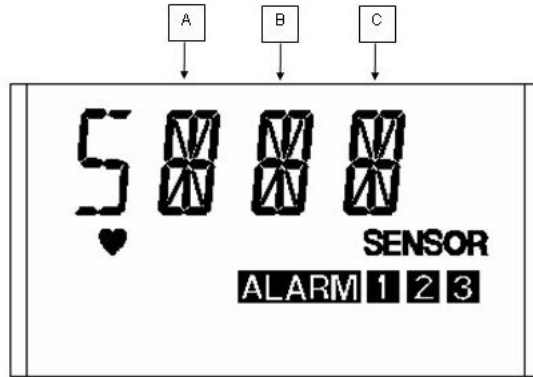

- A. Indicates the status of Sensor #1.
- B. Indicates the status of Sensor #2.
- C. Indicates the status of Sensor #3.

Figure 2-3. Alarm Status Screen

Table 2-1. Status Indication Codes

CODE	INDICATION
"d"	Sensor position disabled
"F"	Sensor position in a fault state
"N"	Sensor position in normal operation, below 50% of range, and not in alarm
"A"	Sensor position in alarm
"L"	Sensor position at or above 50% of range
"M"	Sensor position at or above 60% of range
"H"	Sensor position at or above 90% of range

- The SENSOR, ALARM #1, #2, #3 indicators will still function as normal cycling though each sensor position. This allows the:
 - use of the IR signal to be received for each sensor position
 - user to see what alarms are active for each sensor when the status screen is displayed.

NOTE: In the CSA mode, the display (alarm/fault) locking feature will be removed. This will allow the display to continuously cycle through the three sensors. In doing so, the alarm flags will be displayed as the instrument cycles, preventing the need to display the status screen upon alarm.

Ultima X Controller or Ultima X Calibrator:

- May be used to send commands to display data or set configurations consistent with existing Ultima X procedures
- May be sent at any time for transmitter-specific commands, such as address, baud rate, etc.
- Sensor-specific commands (such as calibration initiation or span value) must be sent while the sensor data (sensor type or gas levels) is displayed

Calibration

Calibration is performed via the:

- **Ultima X Controller**
 - Sends a zero or span command
 - Sensor calibration depends on the sensor number showing on the display when the command is received.
- **Push-button**
 - Depends on the sensor number showing on the display when the command is received.
 - Press and release push-button to acknowledge any conditions
 - With the desired sensor data (sensor or gas level) on the display, press the push-button to activate a calibration
 - Calibration function depends on length of time that the push-button is pressed
 - 5 seconds: zero calibration
 - 10 seconds: span calibration
 - 20 seconds: factory initial calibration
 - Push-button may be factory/user-installed (FIGURE 2-4).
 - See Installation Outline Drawings for details.

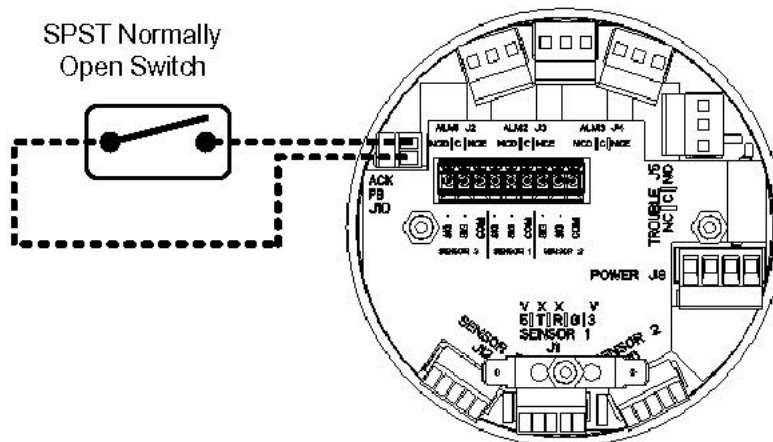

Figure 2-4. Push-button Wiring

- **ModBUS Port**
 - See ModBUS data table definition in this addendum.

⚠ WARNING

During the calibration process, the transmitter is in Maintenance mode, all alarming is inhibited for all sensors, and transmitter will not alert user to potential hazardous situations.

- During the calibration of a sensor, a ModBUS request for the gas level returns the actual value. The other sensors on that specific transmitter are not active. A gas level of -99.9 will be returned to indicate that.

ModBUS Communications

Baud rate and data format defaults per data table specification are adjustable by using a:

- Hand-held Controller or
- ModBUS command.

Each transmitter:

- Is a slave on the communications network
- Must have a unique address and serial format compatible with transmitter configuration.

Section 3, ModBUS

ModBUS Addressing

The ModBUS slave address has a valid range of 1-247.

- 247 is the default value.

This address may be set by:

- The Ultima X Controller:
 - Send an address command with the desired value.
- The Ultima X Calibrator:
 - Press the ADDRESS button once to display the current setting.
 - The ZERO button increments the address number
 - The SPAN button decrements the address number
 - Range for Calibrator is 1 - 32; use Controller for other addresses
 - Press the ADDRESS button again to save the new address.
- A ModBUS controller by writing to the corresponding register in the data table.

ModBUS Communications

- The communications protocol is ModBUS RTU over an RS-485 hardware network.
- The default settings for communications parameters are 19200 baud and even parity.
- The stop bits are fixed at 1 stop bit.
- For data types that are larger than one word, the most significant word is located in the first register (big-endian).

Table 3-1. Supported ModBUS Function Codes

FUNCTION NUMBER	DESCRIPTION
3	Read Holding Registers
5	Write Single Coil
6	Write Single Register
16	Write Multiple Registers

Table 3-2. ModBUS Memory Map Overview

The Modbus port allows for access to a significant amount of information which may be necessary for your system integration requirements. As a minimum, the gas readings and fault status registers should be polled.

DESCRIPTION	START ADDRESS	END ADDRESS	SIZE IN WORDS	ACCESS
ModBUS Data Table Start Base Address	1000	1000	1	Read/Write
Factory Configuration Data	Base+1	Base+18	18	Read Only
User Configuration Data	Base+101	Base+148	48	Read/Write
Status Information	Base+201	Base+253	53	Read Only
Control Words	Base+301	Base+302	2	Read/Write

ModBUS Base Address (Read/Write)

The ModBUS base address register is located at address 1000 and has a default value of 40,000.

- This may be changed by writing a new value within the permissible range to that address.
- Subsequent addresses must take this new base address into consideration.
- The base address may be changed by writing to address 1000, regardless of its contents.

Table 3-3. ModBUS Bas Address (Read/Write)

DESCRIPTION	ADDRESS	POSSIBLE VALUES
ModBUS Data Table Base Address	1000	1000 - 60,000 (default 40,000)

- For systems that use five-digit addressing, 4XXXX:
 - If the first digit is an internal system requirement and does not appear in the communications packet, write the value 1000 to address 41000. The base address is now 41000 and the first valid address is 41001.
 - If all five digits appear in the communications packet, the default base address is 40000 and the first valid address is 40001.

- For systems that use six-digit addressing, 4XXXXX:
 - The first digit is an internal system requirement and does not appear in the communications packet. The base address is 440000, and the first valid address is 440001.

Table 3-4. ModBUS Factory Configuration Data (Read Only)

DESCRIPTION	ADDRESS	POSSIBLE VALUES
Device Type	Base+1	3(Ultima X3 US) 4(Ultima X3 Europe)
Firmware Version	Base+2	0..32767 Integer, divide by 100 for range 00.00 to 99.99
Relays Option Installed	Base+3	0-Relays not installed, 1-Relays installed
Reserved for future use	Base+4	
Date of Mfg Year, Sensor 1	Base+5	20XX
Date of Mfg Month, Sensor 1	Base+6	1..12
Date of Mfg Day, Sensor 1	Base+7	1..31
Date of Mfg Year, Sensor 2	Base+8	20XX
Date of Mfg Month, Sensor 2	Base+9	1..12
Date of Mfg Day, Sensor 2	Base+10	1..31
Date of Mfg Year, Sensor 3	Base+11	20XX
Date of Mfg Month, Sensor 3	Base+12	1..12
Date of Mfg Day, Sensor 3	Base+13	1..31
Full Scale Range- Default Sensor 1	Base+14	Single Precision Float
Full Scale Range- Default Sensor 2	Base+16	Single Precision Float
Full Scale Range- Default Sensor 3	Base+18	Single Precision Float

Table 3-5. ModBUS User Configuration Data (Read/Write)

DESCRIPTION	ADDRESS	POSSIBLE VALUES
ModBUS Slave Address	Base+101	1..247
Baud Rate Code	Base+102	0 - 1200, 1 - 2400 2 - 4800, 3 - 9600 4 - 19200 (default)
Parity Code	Base+103	0 - Even (default) 1 - Odd 2 - None
For future use	Base+104	
For future use	Base+105	
For future use	Base+106	
Full Scale Range, Sensor 1	Base+107	Single Precision Float
Full Scale Range, Sensor 2	Base+109	Single Precision Float
Full Scale Range, Sensor 3	Base+111	Single Precision Float
Span Gas Value, Sensor 1	Base+113	Single Precision Float
Span Gas Value, Sensor 2	Base+115	Single Precision Float
Span Gas Value, Sensor 3	Base+117	Single Precision Float
Alarm 1 Setpoint, Sensor 1	Base+119	Single Precision Float
Alarm 1 Setpoint, Sensor 2	Base+121	Single Precision Float
Alarm 1 Setpoint, Sensor 3	Base+123	Single Precision Float
Alarm 2 Setpoint, Sensor 1	Base+125	Single Precision Float
Alarm 2 Setpoint, Sensor 2	Base+127	Single Precision Float
Alarm 2 Setpoint, Sensor 3	Base+129	Single Precision Float
Alarm 3 Setpoint, Sensor 1	Base+131	Single Precision Float
Alarm 3 Setpoint, Sensor 2	Base+133	Single Precision Float
Alarm 3 Setpoint, Sensor 3	Base+135	Single Precision Float
Alarm Function Word 1	Base+137	0..32767, See detail below
Alarm Function Word 2	Base+138	0..32767, See detail below
Average Time Interval	Base+139	1,8 or 24
Current Date - Year	Base+140	20XX
Current Date - Month	Base+141	1..12
Current Date - Day	Base+142	1..31
Current Time -Hour	Base+143	1..24
Current Time - Minute	Base+144	0..59
Current Time - Second	Base+145	Read Only
Gas Table Number Sensor 1 (XIR)	Base+146	1 Methane, 2 Propane 3 Ethane, 4 Butane 5 Pentane, 6 Hexane 7 Cyclopentane, 8 Ethylene
Gas Table Number Sensor 2 (XIR)	Base+147	Same as above
Gas Table Number Sensor 3 (XIR)	Base+148	Same as above

**Table 3-6. Alarm Function Codes - Word 1
(Read/Write at Address Base+137)**

NAME	BITS	FUNCTION DESCRIPTION
Alarm 1 Enable, Sensor 1	0	1-Enable, 0-Disable
Alarm 1 Enable, Sensor 2	1	1-Enable, 0-Disable
Alarm 1 Enable, Sensor 3	2	1-Enable, 0-Disable
Alarm 2 Enable, Sensor 1	3	1-Enable, 0-Disable
Alarm 2 Enable, Sensor 2	4	1-Enable, 0-Disable
Alarm 2 Enable, Sensor 3	5	1-Enable, 0-Disable
Alarm 3 Enable, Sensor 1	6	1-Enable, 0-Disable
Alarm 3 Enable, Sensor 2	7	1-Enable, 0-Disable
Alarm 3 Enable, Sensor 3	8	1-Enable, 0-Disable
Alarm 1 Direction, Sensor 1	9	1-Increasing, 0-Decreasing
Alarm 1 Direction, Sensor 2	10	1-Increasing, 0-Decreasing
Alarm 1 Direction, Sensor 3	11	1-Increasing, 0-Decreasing
Alarm 2 Direction, Sensor 1	12	1-Increasing, 0-Decreasing
Alarm 2 Direction, Sensor 2	13	1-Increasing, 0-Decreasing
Alarm 2 Direction, Sensor 3	14	1-Increasing, 0-Decreasing
Not used	15	

**Table 3-7. Alarm Function Codes - Word 2
(Read/Write at Address Base+138)**

NAME	BITS	FUNCTION DESCRIPTION
Alarm 3 Direction, Sensor 1	0	1-Increasing, 0-Decreasing
Alarm 3 Direction, Sensor 2	1	1-Increasing, 0-Decreasing
Alarm 3 Direction, Sensor 3	2	1-Increasing, 0-Decreasing
Alarm 1 Latch Status, Sensor 1	3	0 - Non-Latching, 1 - Latching
Alarm 1 Latch Status, Sensor 2	4	0 - Non-Latching, 1 - Latching
Alarm 1 Latch Status, Sensor 3	5	0 - Non-Latching, 1 - Latching
Alarm 2 Latch Status, Sensor 1	6	0 - Non-Latching, 1 - Latching
Alarm 2 Latch Status, Sensor 2	7	0 - Non-Latching, 1 - Latching
Alarm 2 Latch Status, Sensor 3	8	0 - Non-Latching, 1 - Latching
Alarm 3 Latch Status, Sensor 1	9	0 - Non-Latching, 1 - Latching
Alarm 3 Latch Status, Sensor 2	10	0 - Non-Latching, 1 - Latching
Alarm 3 Latch Status, Sensor 3	11	0 - Non-Latching, 1 - Latching
Relay State- without alarm condition	12	1 - Normally Energized, 0 - Normally De-Energized
Relay State- without alarm condition	13	1 - Normally Energized, 0 - Normally De-Energized
Relay State- without alarm condition	14	1 - Normally Energized, 0 - Normally De-Energized
Not used	15	

Table 3-8. ModBUS Device Status (Read only)

DESCRIPTION	ADDRESS	POSSIBLE VALUES
General Status Bits	Base+201	0..32767, See details below
Fault Status Bits	Base+202	0..32767, See details below
Reserve	Base+203	
Gas Type - Sensor 1	Base+204	See TABLE 3-14 for details
Gas Type - Sensor 2	Base+205	See TABLE 3-14 for details
Gas Type - Sensor 3	Base+206	See TABLE 3-14 for details
Gas Level - Sensor 1	Base+207	Single Precision Float
Gas Level - Sensor 2	Base+209	Single Precision Float
Gas Level - Sensor 3	Base+211	Single Precision Float
Engineering Units - Sensor 1	Base+213	See TABLE 3-15 for details
Engineering Units - Sensor 2	Base+214	See TABLE 3-15 for details
Engineering Units - Sensor 3	Base+215	See TABLE 3-15 for details
Calibration Step	Base+216	0. 30 Sec Countdown to Start Zero 1. Waiting for Zero 2. 30 Sec Countdown to Start SPAN 3. Waiting for SPAN 4. Calibration Aborted 5. Zero Cal Fault 6. Span Cal Fault 7. Calibration Completed Successfully
Temperature - Sensor 1	Base+217	Signed Integer
Temperature - Sensor 2	Base+218	Signed Integer
Temperature - Sensor 3	Base+219	Signed Integer
Min Gas Reading over average Interval - Sensor 1	Base+220	Single Precision Float
Min Gas Reading over average Interval - Sensor 2	Base+222	Single Precision Float
Min Gas Reading over average Interval - Sensor 3	Base+224	Single Precision Float
Max Gas Reading over average Interval - Sensor 1	Base+226	Single Precision Float
Max Gas Reading over average Interval - Sensor 2	Base+228	Single Precision Float
Max Gas Reading over average Interval - Sensor 3	Base+230	Single Precision Float
Avg Gas Reading over average Interval - Sensor 1	Base+232	Single Precision Float
Avg Gas Reading over average Interval - Sensor 2	Base+234	Single Precision Float
Avg Gas Reading over average Interval - Sensor 3	Base+236	Single Precision Float
Date of Last Cal Year, Sensor 1	Base+238	20XX

Date of Last Cal Month, Sensor 1	Base+239	1..12
Date of Last Cal Day Sensor 1	Base+240	1..31
Date of Last Cal Year, Sensor 2	Base+241	20XX
Date of Last Cal Month, Sensor 2	Base+242	1..12
Date of Last Cal Day, Sensor 2	Base+243	1..31
Date of Last Cal Year, Sensor 3	Base+244	20XX
Date of Last Cal Month, Sensor 3	Base+245	1..12
Date of Last Cal Day, Sensor 3	Base+246	1..31
Drift counter- Sensor 1	Base+247	0..20
Drift counter- Sensor 2	Base+248	0..20
Drift counter- Sensor 3	Base+249	0..20
Internal Error Code - Ultima X	Base+250	For future implementation
Internal Error Code - Sensor 1	Base+251	For future implementation
Internal Error Code - Sensor 2	Base+252	For future implementation
Internal Error Code - Sensor 3	Base+253	For future implementation
Information Flags 1	Base+254	See TABLE 3-16
Information Flags 2	Base+255	See TABLE 3-17
Information Flags 3	Base+256	See TABLE 3-18
Information Flags 4	Base+257	See TABLE 3-19
Alternate Gas Reading Sensor 1	Base+258	See TABLE 3-20
Alternate Gas Reading Sensor 2	Base+259	See TABLE 3-20
Alternate Gas Reading Sensor 3	Base+260	See TABLE 3-20

**Table 3-9. ModBUS General Status Bits
(Read Only at address Base+201)**

NAME	BIT	FUNCTION DESCRIPTION
Device Fault (any fault)	0	Set for all fault conditions
Calibration Active - Sensor 1	1	Set during calibration
Calibration Active - Sensor 2	2	Set during calibration
Calibration Active - Sensor 3	3	Set during calibration
Warm up Mode	4	Set during startup
Low Alarm Active	5	Set while alarm relay is active N/A Horn Relay Software
Mid Alarm Active	6	Set while alarm relay is active
High Alarm Active	7	Set while alarm relay is active
For future use	8	
For future use	9	
For future use	10	
For future use	11	
For future use	12	
For future use	13	
For future use	14	
Not used	15	

**Table 3-10. ModBUS Fault Status Bits
(Read Only at address Base+202)**

NAME	BIT	FUNCTION DESCRIPTION
Fault Relay Active	0	Set when any fault is detected
Sensor Missing - Sensor 1	1	Set when this fault is detected
Sensor Missing - Sensor 2	2	Set when this fault is detected
Sensor Missing - Sensor 3	3	Set when this fault is detected
Calibration Fault - Sensor 1	4	Set when this fault is detected
Calibration Fault - Sensor 2	5	Set when this fault is detected
Calibration Fault - Sensor 3	6	Set when this fault is detected
Power Fail Fault - Sensor 1	7	Set when this fault is detected
Power Fail Fault - Sensor 2	8	Set when this fault is detected
Power Fail Fault - Sensor 3	9	Set when this fault is detected
Power Fail Fault - Main Unit +5VDC	10	Set when this fault is detected
Sensor End of life - Sensor 1	11	Set when this fault is detected
Sensor End of life - Sensor 2	12	Set when this fault is detected
Sensor End of life - Sensor 3	13	Set when this fault is detected
Ultima X Configuration Reset	14	Set when a datasheet reset occurs
Not used	15	

Table 3-11. Control Words (Read/Write)

DESCRIPTION	ADDRESS	POSSIBLE VALUES
Command Word 1	Base+301	0 to 32767, See TABLE 3-12
Command Word 2	Base+302	0 to 32767, See TABLE 3-13

**Table 3-12. ModBUS Command Word 1
(Read at address Base+301/Write Coils 1 through 16)**

NAME	BITS	COIL	FUNCTION DESCRIPTION
Start Full ICAL Calibration - Sensor 1	0	1	Rtn's fault if any Calibration in progress
Start Full ICAL Calibration - Sensor 2	1	2	Rtn's fault if any Calibration in progress
Start Full ICAL Calibration - Sensor 3	2	3	Rtn's fault if any Calibration in progress
Start Standard Full Calibration - Sensor 1	3	4	Rtn's fault if any Calibration in progress
Start Standard Full Calibration - Sensor 2	4	5	Rtn's fault if any Calibration in progress
Start Standard Full Calibration - Sensor 3	5	6	Rtn's fault if any Calibration in progress
Start Standard Zero Calibration Sensor 1	6	7	Rtn's fault if any Calibration in progress
Start Standard Zero Calibration Sensor 2	7	8	Rtn's fault if any Calibration in progress
Start Standard Zero Calibration Sensor 3	8	9	Rtn's fault if any Calibration in progress
Start UCAL Calibration - Sensor 1	9	10	Rtn's fault if any Calibration in progress
Start UCAL Calibration - Sensor 2	10	11	Rtn's fault if any Calibration in progress
Start UCAL Calibration - Sensor 3	11	12	Rtn's fault if any Calibration in progress
Step UCAL	12	13	1 to step
Abort Calibration (any)	13	14	1 to abort
Reserved for future use	14	15	
Not used	15	16	

**Table 13-13 ModBUS Command Word 2
(Read at address Base+302/Write Coils 17 through 32)**

NAME	BIT	COIL	FUNCTION DESCRIPTION
Sensor Swap Delay	0	17	1-Enable, 0-Disable
Alert Option Enable	1	18	1-Enable, 0-Disable
Acknowledge or Reset Latched Alarms(ACK)	2	19	1 to initiate (same functionality as Push-button or IR command)
Reset Main Board and sensors	3	20	1 to initiate
For future use	4	21	
For future use	5	22	
Reset Data Sheet - Sensor 1	6	23	1 to initiate
Reset Data Sheet - Sensor 2	7	24	1 to initiate
Reset Data Sheet - Sensor 3	8	25	1 to initiate
Disable Sensor 1	9	26	1 to Disable
Disable Sensor 2	10	27	1 to Disable
Disable Sensor 3	11	28	1 to Disable
Reserved for future use	12	29	
Reserved for future use	13	30	
Reserved for future use	14	31	
Not used	15	32	

Table 3-14. Sensor Type

SENSOR TYPE VALUE	SENSOR TYPE
13	COMB-1S 100% LEL, 1% LEL, 25% LEL (0.6% Propane)
257	CO 100 PPM, 1 PPM, MSA 25E/F, 60 PPM
258	CO 500 PPM, 1 PPM, MSA 25E/F, 300 PPM
259	SO ₂ 25 PPM, 1 PPM, CTL 7ST/F, 10 PPM
260	H ₂ S 10.0 PPM, 0.1 PPM, MSA HS25B, 5.0 PPM
261	H ₂ S 50.0 PPM, 0.1 PPM, MSA HS25B, 40 PPM
262	H ₂ S 100 PPM, 1 PPM, MSA HS25D, 40 PPM
263	NO 100 PPM, 1 PPM, CTL 7NT, 50 PPM
264	NO ₂ 10.0 PPM, 0.1 PPM, MSA ND25C, 5.0 PPM
265	CL ₂ 5.0 PPM, 0.1 PPM, MSA CL25B, 2.0 PPM
266	HCN 50 PPM, 1 PPM, MSA HN25C, 10 PPM
267	HCL 50 PPM, 1 PPM, MSA HL25C, 40 PPM
12	O ₂ 25.0%, 0.1%, MSA 10019727, 20.8%
14	COMB-1S 100%LEL, 1% LEL, 40% LEL

15	COMB-1S 100%LEL, 1% LEL, 55% LEL
16	COMB-1S-NL 100%LEL, 1% LEL, 25% LEL
17	COMB-1S-NL 100%LEL, 1% LEL, 40% LEL
18	COMB-1S-NL 100%LEL, 1% LEL, 55% LEL
275	CLO ₂ 3.0 PPM, 0.1 PPM, MSA 7CLH, 1.0 PPM
276	NH ₃ 100 PPM, 1 PPM, SENSORIC, 25 PPM
277	H ₂ , 1000 PPM, 10 PPM, CTL 7HYT, 300 PPM
279	PHOSPHINE, 2.0 PPM, 0.1 PPM CTL 7SH, 0.5 PPM
280	ARSINE, 2.0 PPM, 0.1 PPM, CTL 7SH, 1.0 PPM
281	SILANE, 25 PPM, 1 PPM, CTL 7SH, 5 PPM
282	GERMANE, 3.0 PPM, 0.1 PPM, CTL 7SH, 2.5 PPM
283	DIBORANE, 50 PPM, 1 PPM, CTL 7SH, 15 PPM
284	FLUORINE, 5.0 PPM, 0.1 PPM, MSA 7CLH, 4.0 PPM
285	HF
286	BROMINE, 5.0 PPM, 0.1 PPM, MSA 7CLH, 2.5 PPM
287	ETO, 10.0 PPM, 0.1 PPM, 5 PPM
288	O ₂ 10.0%, 0.1% MSA 10019727, 5.0%
2	IRIS
19	COMB-1S-100% LEL, 10% LEL, 31% LEL
20	COMB-1S-100% LEL, 1% LEL, 49% LEL
21	COMB-1S-100% LEL, 1% LEL, 68% LEL
22	Tankerguard
290	CLO ₂ 0.02 resolution
289	NH ₄ 1000
291	H ₂ S 500
3	Custom IRIS 0-10000 PPM
101	IRIS - start
to	IRIS - cont.
150	IRIS - finish

Table 3-15. Sensor Engineering Units

UNIT LABEL VALUE	UNIT LABEL
0	None
1	% LEL
2	%
3	PPM
4	Future Expansion

**Table 3-16. Information Flags Word #1 –
(Read at address Base+254)**

NAME	BITS	FUNCTION DESCRIPTION
Sensor # 1 Disabled	0	0 = enabled, 1 = disabled
Sensor # 2 Disabled	1	0 = enabled, 1 = disabled
Sensor # 3 Disabled	2	0 = enabled, 1 = disabled
Alarm # 1 Sensor # 1	3	0 = clear, 1 = set
Alarm # 2 Sensor # 1	4	0 = clear, 1 = set
Alarm # 3 Sensor # 1	5	0 = clear, 1 = set
Alarm # 1 Sensor # 2	6	0 = clear, 1 = set
Alarm # 2 Sensor # 2	7	0 = clear, 1 = set
Alarm # 3 Sensor # 2	8	0 = clear, 1 = set
Alarm # 1 Sensor # 3	9	0 = clear, 1 = set
Alarm # 2 Sensor # 3	10	0 = clear, 1 = set
Alarm # 3 Sensor # 3	11	0 = clear, 1 = set
Cal Fault Condition Sensor #1	12	0 = Zero, 1 = Span
Cal Fault Condition Sensor #2	13	0 = Zero, 1 = Span
Cal Fault Condition Sensor #3	14	0 = Zero, 1 = Span
Not Used	15	

**Table 3-17. Information Flags Word #2
(Read at address Base+255)**

NAME	BITS	FUNCTION DESCRIPTION
Configuration Reset	0	Set if TRUE
Fault RAM Main	1	Set if TRUE
FAULT FLASH MAIN	2	Set if TRUE
EEPROM WRITE ERROR	3	Set if TRUE
MUX FAULT	4	Set if TRUE
FAULT INCOMPATIBLE SENSOR #1	5	Set if TRUE
FAULT INCOMPATIBLE SENSOR #2	6	Set if TRUE
FAULT INCOMPATIBLE SENSOR #3	7	Set if TRUE
Quick under range sensor #1	8	Set if TRUE
Quick under range sensor #2	9	Set if TRUE
Quick under range sensor #3	10	Set if TRUE
Under range Sensor #1	11	Set if TRUE
Under range sensor #2	12	Set if TRUE
Under range sensor #3	13	Set if TRUE
Atex Enabled	14	0 = Disabled, 1 = Enabled
Swap Delay	15	0 = Disabled, 1 = Enabled

**Table 3-18. Information Flags Word #3
(Read at address Base+26)**

NAME	BITS	FUNCTION DESCRIPTION
Overrange Flag sensor #1	0	Set if TRUE
Overrange Flag sensor #2	1	Set if TRUE
Overrange Flag sensor #3	2	Set if TRUE
LOC Flag sensor #1 1	3	Set if TRUE
LOC Flag sensor #2 1	4	Set if TRUE
LOC Flag sensor #3 1	5	Set if TRUE
Parameter Fault Sensor #1	6	Set if TRUE
Parameter Fault Sensor #2	7	Set if TRUE
Parameter Fault Sensor #3	8	Set if TRUE
Warm up Sensor #1 1	9	Set if TRUE
Warm up Sensor #2 1	10	Set if TRUE
Warm up Sensor #3 1	11	Set if TRUE
Sensor Configuration Reset #1	12	Set if TRUE
Sensor Configuration Reset #2	13	Set if TRUE
Sensor Configuration Reset #3	14	Set if TRUE
Not Used	15	

**Table 3-19. Information Flags Word #4
(Read at address Base+257)**

NAME	BITS	FUNCTION DESCRIPTION
Underrange Average Interval S1	0	Set if TRUE
Underrange Average Interval S2	1	Set if TRUE
Underrange Average Interval S3	2	Set if TRUE
Overrange Average Interval S1	3	Set if TRUE
Overrange Average Interval S2	4	Set if TRUE
Overrange Average Interval S3	5	Set if TRUE
Sensor Warning Sensor #1	6	Set if TRUE
Sensor Warning Sensor #2	7	Set if TRUE
Sensor Warning Sensor #3	8	Set if TRUE
Not Used	9	
Not Used	10	
Not Used	11	
Not Used	12	
Not Used	13	
Not Used	14	
Not Used	15	

**Table 3-20. Alternate Gas Readings
(Read/Write at address Base+258 to Base+260)**

DESCRIPTION	VALUE
Normal Gas Detection	400-2000
Fault	230
Overrange	2110
Suppressed	305
Disabled	0