



Chillgard[®] LS Refrigerant Monitor

Instruction Manual

▲ WARNING

THIS MANUAL MUST BE CAREFULLY READ BY ALL INDIVIDUALS WHO HAVE OR WILL HAVE THE RESPONSIBILITY FOR USING OR SERVICING THE PRODUCT. Like any piece of complex equipment, this instrument will perform as designed only if it is used and serviced in accordance with the manufacturer's instructions. OTHERWISE, IT COULD FAIL TO PERFORM AS DESIGNED AND PERSONS WHO RELY ON THIS PRODUCT FOR THEIR SAFETY COULD SUSTAIN SEVERE PERSONAL INJURY OR DEATH.

The warranties made by Mine Safety Appliances Company with respect to the product are voided if the product is not used and serviced in accordance with the instructions in this manual. Please protect yourself and others by following them. We encourage our customers to write or call regarding this equipment prior to use or for any additional information relative to use or repairs.

IN NORTH AMERICA: 1-800-MSA-INST. or FAX (724) 776-9783

IN CANADA: 1-800-267-0672 or FAX (416) 663-5908

MSA INTERNATIONAL (412) 967-3354 or FAX (412) 967-3373

© MINE SAFETY APPLIANCES COMPANY 2009 - All Rights Reserved

This manual is available on the internet at www.msanet.com

Manufactured by

MSA NORTH AMERICA

P.O. Box 427, Pittsburgh, Pennsylvania 15230

(L) Rev 7

10035164



Chillgard LS Diffusion Refrigerant Monitor



Chillgard LS Pumped Refrigerant Monitor

MSA Permanent Instrument Warranty

- 1. Warranty-** Seller warrants that this product will be free from mechanical defect or faulty workmanship for a period of two years from date of shipment, provided it is maintained and used in accordance with Seller's instructions and/or recommendations. This warranty does not apply to expendable or consumable parts whose normal life expectancy is less than one (1) year such as, but not limited to, non-rechargeable batteries, filament units, filter, lamps, fuses etc. The Seller shall be released from all obligations under this warranty in the event repairs or modifications are made by persons other than its own or authorized service personnel or if the warranty claim results from physical abuse or misuse of the product. No agent, employee or representative of the Seller has any authority to bind the Seller to any affirmation, representation or warranty concerning the goods sold under this contract. Seller makes no warranty concerning components or accessories not manufactured by the Seller, but will pass on to the Purchaser all warranties of manufacturers of such components.

THIS WARRANTY IS IN LIEU OF ALL OTHER WARRANTIES, EXPRESSED, IMPLIED OR STATUTORY, AND IS STRICTLY LIMITED TO THE TERMS HEREOF. SELLER SPECIFICALLY DISCLAIMS ANY WARRANTY OF MERCHANTABILITY OR OF FITNESS FOR A PARTICULAR PURPOSE.
- 2. Exclusive Remedy-** It is expressly agreed that Purchaser's sole and exclusive remedy for breach of the above warranty, for any tortious conduct of Seller, or for any other cause of action, shall be the repair and/or replacement at Seller's option, of any equipment or parts thereof, which after examination by Seller is proven to be defective. Replacement equipment and/or parts will be provided at no cost to Purchaser, F.O.B. Seller's Plant. Failure of Seller to successfully repair any non-conforming product shall not cause the remedy established hereby to fail of its essential purpose.
- 3. Exclusion of Consequential Damage-** Purchaser specifically understands and agrees that under no circumstances will seller be liable to purchaser for economic, special, incidental or consequential damages or losses of any kind whatsoever, including but not limited to, loss of anticipated profits and any other loss caused by reason of non-operation of the goods. This exclusion is applicable to claims for breach of warranty, tortious conduct or any other cause of action against seller.

WARNINGS

1. Each instrument described in this manual must be installed, operated, and maintained in strict accordance with its labels, cautions, warnings, instructions, and within the limitations stated.
2. These monitors must not be installed in outdoor areas or in areas or locations where explosive concentrations of combustible gases or vapors might occur in the atmosphere: Class 1, Group A, B, C, and D areas as defined by the NEC. Because the monitors are not explosion-proof, they must be located in non-hazardous areas.
3. The Chillgard LS Refrigerant Monitor is designed to detect refrigerant gases in the air. It cannot measure the concentration of these gases in a steam type atmosphere.
4. As with all gas detection instruments of this type, high levels of or long exposure to certain compounds in the tested atmosphere contaminate the sensor. In atmospheres where the monitor may be exposed to such materials, calibration must be performed frequently to ensure that system operation is dependable and its indications accurate.
5. The Chillgard LS Refrigerant Monitor must not be painted. Painting will interfere with the sampling process of the instrument. If painting is being done in an area where the instrument is located, care must be exercised to insure that paint is not put or splashed on the instrument.
6. The only absolute method to assure the proper overall operation of a gas detection instrument is to check it with a known concentration of the gas for which it has been calibrated. Consequently, a calibration check must be included as part of the routine inspection of the system.
7. The sensor is a sealed unit. Do not attempt to modify or adjust the sensing cell.
8. Use only genuine MSA replacement parts when performing any maintenance procedures provided in this manual. Failure to do so may seriously impair instrument performance. Repair or alteration of the Chillgard LS Refrigerant Monitor, beyond the scope of these maintenance instructions or by anyone other than an authorized MSA service person, could cause the product to fail to perform as designed, and persons who rely on this product for their safety could sustain serious personal injury or death.
9. Ensure that the Chillgard LS Refrigerant Monitor is installed in a clean and dry area as possible. Install splash or rain shields on the instrument to keep water and other contaminants away from the instrument. If you fail to follow this warning, equipment damage can occur.

10. Ensure that the Chillgard LS Refrigerant Monitor and the area the instrument is monitoring is at the same temperature before operation of the instrument; otherwise, condensation will form and possibly clog or fill the gas sensor in the instrument rendering the instrument inoperable.
11. Protect the Monitor from vibration and heating; otherwise, improper operation may result, which can result in personal injury or death.

**FAILURE TO FOLLOW THE ABOVE WARNINGS CAN RESULT IN SERIOUS
PERSONAL INJURY OR DEATH.**

Table of Contents

Chapter 1 General Information1-1

Figure 1-1. Identification Label Location	1-1
Terminology Used in this Manual	1-2
General Description	1-3
Applications	1-3
Table 1-1. General Operating Specifications for all Models	1-4
Table 1-2. Typical Chillgard LS / R-11 Cross-Sensitivity Response Data	1-5
Table 1-3. Typical Chillgard LS / R-12 Cross-Sensitivity Response Data	1-5
Table 1-4. Typical Chillgard LS / R-22 Cross-Sensitivity Response Data	1-6
Table 1-5. Typical Chillgard LS / R-123 Cross-Sensitivity Response Data	1-6
Table 1-6. Typical Chillgard LS / R-134 A Cross-Sensitivity Response Data	1-7

Chapter 2 Installation and Set-up2-1

Unpacking the System	2-1
Initial Inspection	2-1
Sensor Location	2-1
Pumped Units	2-1
Diffusion Units	2-2
▲ CAUTION	2-2
Mounting the Unit	2-3
Five rules for proper mounting	2-3
Mounting	2-3
▲ WARNING	2-3
Figure 2-1. Diffusion Style Mounting Dimensions ..	2-4
Figure 2-2. Four-Point Pumped Style Mounting Dimensions	2-5

Wiring Connections	2-6
Opening the Unit	2-6
Wiring	2-6
▲ CAUTION	2-6
▲ CAUTION	2-6
Figure 2-3. Diffusion Style Electrical Connections ..	2-7
Figure 2-4. Four-Point Pumped Style Electrical Connections	2-7
For 24 V DC or AC Wiring	2-8
For 110/220 VAC Wiring	2-8
Figure 2-5. Sensor Board Connections	2-8
Analog Signal Output Wiring	2-9

Chapter 3 Start-up and Initial Adjustments 3-1

Operation	3-1
Start-Up	3-1
General Calibration (All Models)	3-1
Introduction	3-1

Chapter 4 Calibration 4-1

Figure 4-1. Calibration Equipment	4-1
▲ WARNING	4-1
Diffusion Version Calibration	4-1
Calibration Equipment - (FIGURE 4-1)	4-1
Initial Calibration Procedures	4-2
Preparation for Calibration	4-2
Initial Calibration	4-2
▲ CAUTION	4-2
▲ CAUTION	4-2
Figure 4-2. Applying Calibration Gas to the Chillgard LS Refrigerant Monitor	4-3
Calibration Guidelines	4-4
Calibration Equipment	4-4
Calibration Check Procedure	4-5
Applying Calibration Gases to the Instrument	4-5

▲ CAUTION	4-5
Four-Point Pumped Version Calibration	4-6
Introduction	4-6
Calibration Equipment	4-6
▲ CAUTION	4-6
Figure 4-3. Kit Components	4-7
▲ CAUTION	4-7
Table 4-1. RP Calibration Gases	4-8
Calibration Procedures	4-8
Preparation for Calibration	4-8
▲ CAUTION	4-8
▲ WARNING	4-8
▲ CAUTION	4-8
Initial Calibration	4-9
Calibration Guidelines	4-9
Calibration Equipment	4-10
Calibration Check Procedure	4-10
Zeroing the Monitor	4-10
▲ WARNING	4-10
Figure 4-4. Using Zero Scrubber for Zero Calibration	4-11
Figure 4-5. Using Zero Gas Cylinder for Zero Calibration	4-11
Figure 4-6. Span Calibration	4-12
▲ CAUTION	4-12
▲ CAUTION	4-13

Chapter 5

Service and Replacement Parts5-1

Troubleshooting Guidelines	5-1
Table 5-1. Troubleshooting Guidelines	5-1
Table 5-2. Calibration Accessories Parts List	5-2
Table 5-3. Replacement Parts List	5-3
Service and Assistance	5-4

Appendix A
Installation Outline DrawingsA-1

Figure A-1. Diffusion Style Chillgard LS
Installation DrawingA-1

Appendix B
RS-485 OutputB-1

Table B-1. Dip Switch PositionsB-1
Table B-2. Sensor Unit Register AddressesB-2

Chapter 1

General Information

The Chillgard LS Refrigerant Monitor provides a continuous indication of a refrigerant concentration in air. It is capable of monitoring a refrigerant from 0 to 1000 parts per million (ppm). Each instrument is factory-calibrated to a certain full-scale value of a specific refrigerant.

All Chillgard LS Refrigerant Monitors use infrared photo-acoustic sensors. These sensors give an indication of refrigerant levels without requiring oxygen to be present. Also, the sensors are not poisoned or degraded in the presence of most silicon or sulfur compounds.

Each Chillgard LS Refrigerant Monitor is placed in an area where a refrigerant is anticipated or must be controlled. The Monitor operates in either the Diffusion style (gas diffuses into the sensor through the opening located at the bottom of the unit) or the Pumped style (an internal pump draws the sample into the sensor from a remote location). The gas sensor determines the refrigerant concentration and outputs an electrical analog signal proportionate to the concentration.

The Chillgard LS Refrigerant Monitor contains all components necessary to properly sample an area or duct for a refrigerant.

This manual describes all of the various Chillgard LS Refrigerant Monitors, although your monitor may not be equipped with all of the options available.

To help determine what options are on your unit, see the identification label on the side of the instrument (FIGURE1-1).

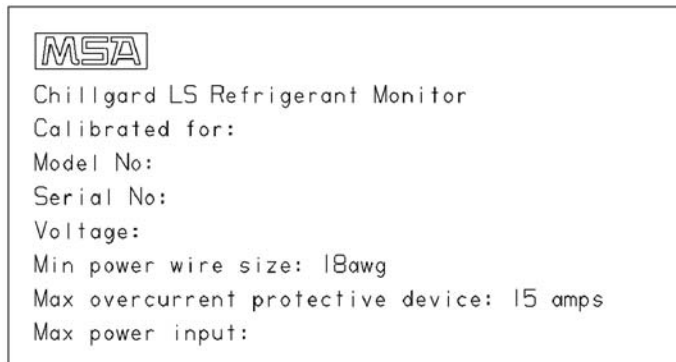

Figure 1-1. Identification Label Location

This label contains:

- model number
- the refrigerant that the unit will detect
- information concerning proper voltages and frequency required to power the unit

Terminology Used in this Manual

FLOW RATE:

Volume of gas drawn through the sample line per minute.

EXHAUST GAS:

Sample gas after it passes through the sensor.

FRESH AIR:

Air that has no possibility of containing refrigerant gas. Contamination with refrigerant gas would interfere with the calibration and the flushing of the instrument.

ZERO:

A zero (0) output usually indicates ambient air present or no refrigerant gases present.

SCRUBBER:

An activated carbon filter which removes and cleans the span gas in the calibration operation prior to exhausting excess gas to ambient air.

ZEROING:

The process of placing a zero indication on the output of the instrument.

SPAN:

A full-scale or up-scale reading on the output of the instrument.

SPANNING:

The process of placing a full-scale or up-scale output of the instrument.

SPAN GAS VALUE:

The gas “concentration” that gives the instrument a full-scale or up-scale output; this value is usually printed on the gas cylinder.

General Description

The Chillgard LS Refrigerant Monitor:

- provides a continuous indication of a refrigerant gas concentration
- operates on the photo acoustic principle, and measures the concentration of a refrigerant in a complex mixture of background gases.

In the photo acoustic principle, sample gas is delivered to an enclosed chamber which is periodically bombarded with infrared (IR) radiation. If the target gas is present, it absorbs IR with each pulse of light. These pulses are miniature sound waves which are picked up by a microphone. The sound level is directly proportional to the target gas concentration present in the gas chamber.

- is capable of measuring a refrigerant 0 to 1000 ppm full scale
- is housed in a rugged plastic enclosure
- has a standard 4 to 20 mA and RS-485 output
- has five LEDs to indicate power, fault and alarm conditions
- is highly selective to enable operation in areas with varying humidity or in areas containing other contaminants. It may be used for applications requiring long-term stability and low maintenance.

Applications

The Chillgard LS Refrigerant Monitor is factory-calibrated for a refrigerant and can be used for applications such as:

- ventilation control
- ambient air monitoring for health and safety purposes.

Table 1-1. General Operating Specifications for all Models

PERFORMANCE SPECIFICATIONS

LINEARITY	20 to 100 ppm	±5 ppm
	100 to 1000 ppm	±6% of reading
REPEATABILITY	±8 ppm	
WARM-UP TIME	10 minutes	
RESPONSE TIME	50% of a step-change in < 70 seconds	
OPERATING TEMP.	0 to 40°C (32 to 104°F)	
TEMP. EFFECT	< 4% / 10° C	
RELATIVE HUMIDITY	0 to 95%, RH non-condensing	
RH EFFECT	R11: less than 3% full scale Other refrigerants: less than 1.5% full scale	

OPERATING SPECIFICATIONS

POWER REQUIREMENTS	24 VDC, +10%, -0%, .85A	
	24 VAC, ±10%, 50/60 Hz, .80A	
	100 to 240 VAC, 50/60, Hz, .3A	
ANALOG OUTPUT	4 to 20 mA, non-isolated, sourcing	
DEFAULT ALARM VALUES	R123: 50, 150, 300 ppm	
	Other applications: 50, 150, 1000 ppm	
MAX. OUTPUT SIGNAL LOAD	500 ohms	
DIMENSIONS	7.1" high x 10" wide x 4.25" deep	
DIFFUSION VERSION	(188 mm high x 110 mm wide x 70 mm deep)	
DIMENSIONS	14.7" high x 11.2" wide x 5" deep	
PUMPED VERSION	(373 mm high x 284 mm wide x 127 mm deep)	
WEIGHT DIFFUSION VERSION	3.7 pounds (1.678 kg.)	
WEIGHT PUMPED VERSION	9.5 pounds (4.308 kg.)	
SAMPLE FLOW RATE	Typically 1.5 LPM; .	
PUMPED VERSION	.75 LPM with maximum tubing length	
MAX. SAMPLE TUBING LENGTH PUMPED VERSION	300 feet with 1/8" ID tubing	
MAX. EXHAUST TUBING LENGTH PUMPED VERSION	30 feet with 1/4" ID tubing	

TRANSPORT AND STORAGE CONDITIONS

TEMP.	-40 to 60° Centigrade (-40 to 140°F)
HUMIDITY	0 to 99% relative humidity
POLLUTION DEGREE AND INSTALLATION CATEGORY	2
ALTITUDE	2000 meters maximum

Table 1-2. Typical Chillgard LS / R-11 Cross-Sensitivity Response Data

GAS	CONCENTRATION (PPM)	EQUIVALENT PPM R-11
Acetone	100	14
Methyl Ethyl Ketone	100	32
Methanol	1000	130
iso-Propanol	500	400
Methylene Chloride	100	0
Xylene	100	0
Ammonia	50	0
R-113	100	25
R-11	100	100
R-22	100	30
R-12	983	490
R-134 A	100	20
R-123	100	3
Propane	0.6%	18
Ethylene	500	20

TEST CONDITIONS: Calibrated 0-1000 PPM R-11 in N₂; Temperature: 25°C

Table 1-3. Typical Chillgard LS / R-12 Cross-Sensitivity Response Data

GAS	CONCENTRATION (PPM)	EQUIVALENT PPM R-12
Acetone	100	3
Methyl Ethyl Ketone	1000	25
Methanol	1000	2
Methylene Chloride	1000	14
Trichloroethylene	1000	167
Ethyl Acetate	1000	22
Xylene (ortho-Xylene)	1000	5
R-113	100	35
R-11	100	5
R-22	100	1
R-12	100	100
R-134 A	100	2
R-114	100	45

TEST CONDITIONS: Calibrated 0-1000 PPM R-12 in N₂; Temperature: 25°C

Table 1-4. Typical Chillgard LS / R-22 Cross-Sensitivity Response Data

GAS	CONCENTRATION (PPM)	EQUIVALENT PPM R-22
Acetone	100	<1
R-11	100	16
R-123	100	35
R-134 A	100	25
R-132 A	100	40
R-22	100	100
R-113	100	39

TEST CONDITIONS: Calibrated 0-1000 PPM R-22 in N₂; Temperature: 25°C

Table 1-5. Typical Chillgard LS / R-123 Cross-Sensitivity Response Data

GAS	CONCENTRATION (PPM)	EQUIVALENT PPM R-123
Acetone	100	22
Methyl Ethyl Ketone	500	48
Methanol	100	2
iso-Propanol	100	5
Methylene Chloride	1000	14
Trichloroethylene	1000	4
Ethyl Acetate	100	42
Xylene (ortho-Xylene)	1000	5
Ammonia	910	7
Natural Gas	1000	5
R-113	100	80
R-11	100	<1
R-22	100	4
R12	100	8
R-134 A	100	140
R-123	100	100

TEST CONDITIONS: Calibrated 0-1000 PPM R-123 in N₂; Temperature: 25°C

Table 1-6. Typical Chillgard LS / R-134 A Cross-Sensitivity Response Data

GAS	CONCENTRATION (PPM)	EQUIVALENT PPM R-134 A
Acetone	100	15
Methyl Ethyl Ketone	500	30
Methanol	100	1
iso-Propanol	100	3
Methylene Chloride	1000	10
Trichloroethylene	1000	3
Ethyl Acetate	100	28
Xylene (ortho-Xylene)	1000	3
Ammonia	910	5
Natural Gas	1000	3
R-113	100	55
R-11	100	<1
R-22	100	3
R12	100	6
R-134 A	100	100
R-123	100	70

TEST CONDITIONS: Calibrated 0-1000 PPM R-134 A in N₂. Temperature: 25°C

Chapter 2 Installation and Set-up

Unpacking the System

To unpack the Chillgard LS Refrigerant Monitor:

- Carefully remove the unit from its shipping container(s) to prevent damage to sensitive electrical and gas sensing components.
- Search through packing material and inside of the containers to prevent inadvertently discarding usable or valuable parts.
- Remove the plastic screws holding the cover to the enclosure.
- Remove the front cover from the Chillgard LS Refrigerant Monitor to expose the electrical printed circuit board.

Initial Inspection

With the front cover open, carefully inspect the components and assemblies inside the enclosure. If damage or shortage is noted, promptly make the proper claim with the carrier.

Sensor Location

Pumped Units

Pumped units use an internal sample pump to pull refrigerant gas from a remote location(s). The visual indication for the unit is located on the front of the unit. Other outputs are available on the device which can be used to provide indication of gas concentration, alarm status, and instrument status.

Refrigerants concentrate near the floor. In typical mechanical equipment room applications, sampling 12-18 inches above the floor is sufficient for early warning and to provide adequate protection for someone working close to the floor. If it is expected that an occupant's breathing zone may be less than 12-18 inches off the floor, locate the sampling point accordingly.

NOTE: Select sampling locations that result in the shortest possible line length in order to reduce transport time.

Consider the following guidelines when selecting the location for the sampling point(s).

1. Most refrigerants are heavier than air and sink to the floor or accumulate in low areas.
2. Place the end of the sampling line in an area that provides the instrument with a representative sample; ventilation Smoke Tubes (P/N 458480) are useful in determining air flow patterns in ambient sampling areas.
3. Properly exhaust the instrument to a safe area or to outside atmosphere.
4. Ensure the sampling area is free of particulate matter and condensing moisture; ensure sample lines will not draw moisture up into the line.

NOTE: The sample gas must be adequately filtered before entering the instrument. End-of-sample-line filters must be used with the unit. These filters must be installed at the end of all sample lines.

5. Ensure the end of the sampling line is unobstructed to allow the sample to flow freely to the instrument.
6. Keep sample lines as short as possible to reduce transport time.

⚠ CAUTION

Ensure that tubing radii are wide enough to prevent kinking or bending. Otherwise, an obstruction may occur, preventing the instrument from sampling the intended area.

7. DO NOT:

- back-pressure the exhaust line or
- connect it to a vacuum source or
- install a flow meter in the exhaust line.

ALWAYS :

connect an exhaust line that is vented to a safe area or an outside atmosphere.

Diffusion Units

Diffusion units sample the refrigerant gas located at the base of the refrigerant monitor. The visual indication for the unit is located on the front of the unit. Other outputs are on the device can be used to provide gas concentration, alarm status, and instrument status indications.

Consider the following guidelines when selecting the location for the sampling point(s):

1. Most refrigerants are heavier than air and sink to the floor or accumulate in low areas.
2. Place the instrument in an area that provides it with a representative sample; ventilation Smoke Tubes (P/N 458480) are useful in determining air flow patterns in ambient sampling areas.
3. Ensure that the area around the instrument is unobstructed to allow the sample to flow freely to the instrument.
4. If the unit's visual indication is used to alert workers of potential gas hazards, mount the instrument in a clearly visible location.

NOTE: The diffusion unit is appropriate for applications where the indication panel is clearly visible with the unit mounted 12-18 inches off the floor; otherwise, a pumped unit located at eye level with sensor points located 12-18 inches off the floor may be more appropriate.

Mounting the Unit

Five Rules for Proper Mounting

1. Do not mount the unit to structures subject to vibration and shock.
2. Do not locate the unit near an excessive heat source.
3. For proper cooling, allow at least three inches of clearance around all surfaces, except for the mounting surface.
4. Do not mount the unit where it will be exposed to direct solar heating, rain and splashing water.
5. Mount the unit where it is accessible for maintenance.

Mounting

WARNING

Do not mount more than one pumped unit to the same mounting structure. Mechanical vibration produced from one unit can cause improper gas readings on another unit.

Do not locate these units in an area that may contain a flammable mixture of gas and air; otherwise, an explosion may occur.

Install the Chillgard LS Refrigerant Infrared Monitor in the area where a refrigerant is anticipated or control of the gas is desired.

Ventilation Smoke Tubes (P/N 458480) are useful in determining air flow patterns in ambient sampling areas.

1. Open the unit by removing the plastic screws securing the lid to the enclosure.
2. Using #10 mounting screws or bolts (FIGURES 2-1 and 2-2), securely mount the Chillgard LS Refrigerant Monitor to a wall or flat mounting surface via the four holes that run through the enclosure base.

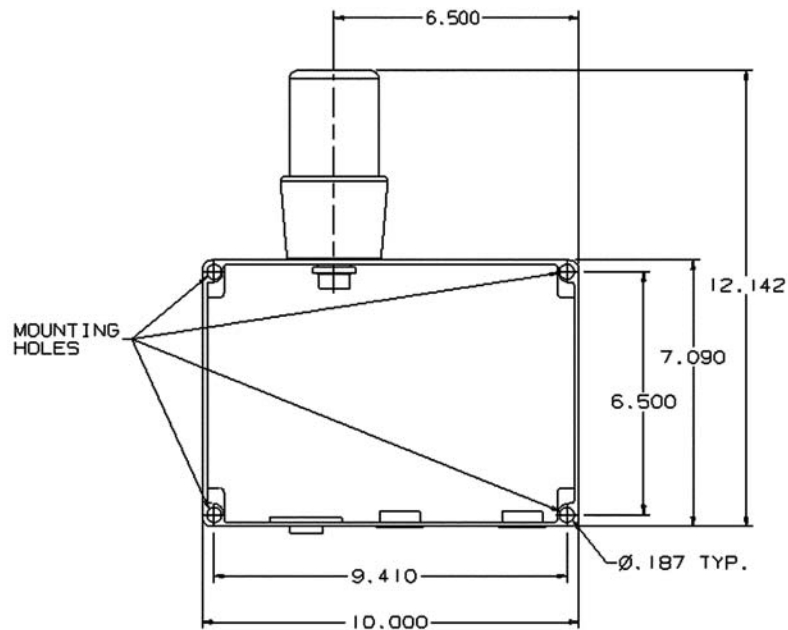

Figure 2-1. Diffusion Style Mounting Dimensions

3. When applying an external sample line to the pumped unit, use the fittings provided at the bottom of the enclosure. Do not place any restriction on the exhaust port located on the right side of the enclosure. Do not place greater than 30 feet of tubing on the exhaust port located on the bottom right of the enclosure.
4. Reinstall the cover to the unit.

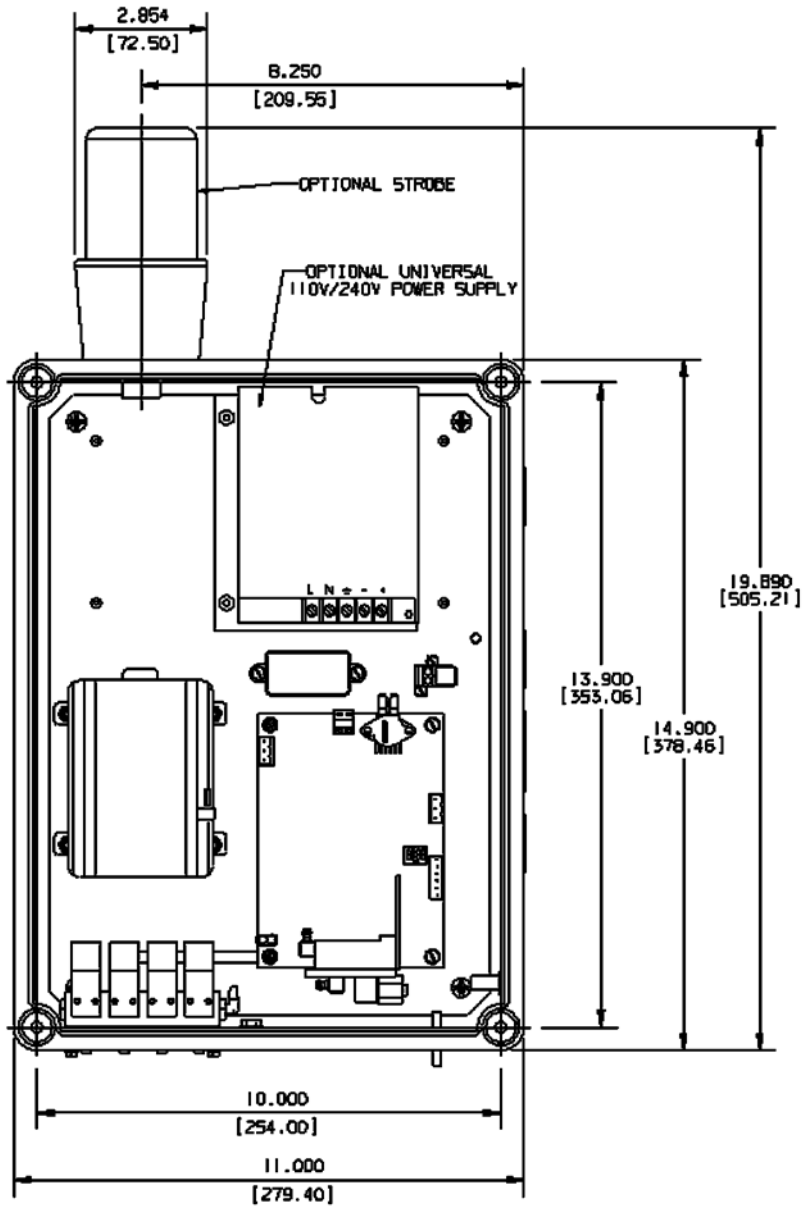

Figure 2-2. Four-Point Pumped Style Mounting Dimensions

Wiring Connections

Opening the Unit

See Appendix A, "Installation Outline Drawings" for wire entry hole locations.

CAUTION

Do not open the cover unless the monitor is protected from splashing, spraying, or dripping water; otherwise, damage to the internal components may result.

Wiring

The Chillgard LS Refrigerant Monitor is factory-wired with either a universal power supply for 110/220 VAC operation or no power supply for 24 V AC/DC operation. Refer to FIGURE 1-1 to determine power requirement for the unit.

The following steps outline the procedure for connecting the wiring:

1. Determine the power supply for your Chillgard LS Refrigerant Monitor (FIGURE 1-1).

CAUTION

If unsure of the power voltage available, contact your facility engineer or safety officer. Instrument damage may occur if incorrect power voltage is applied to the instrument.

NOTE: External overcurrent shall be included in the building installation, shall be in close proximity to the equipment and within easy reach of the operator, and shall be marked as the disconnecting device for the equipment.

All power wiring is connected to the terminal block (FIGURE 2-2 and FIGURE 2-3).

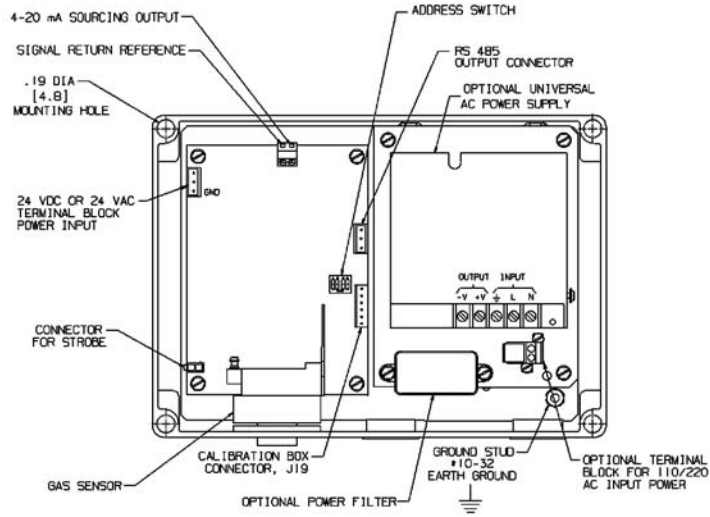

Figure 2-3. Diffusion Style Electrical Connections

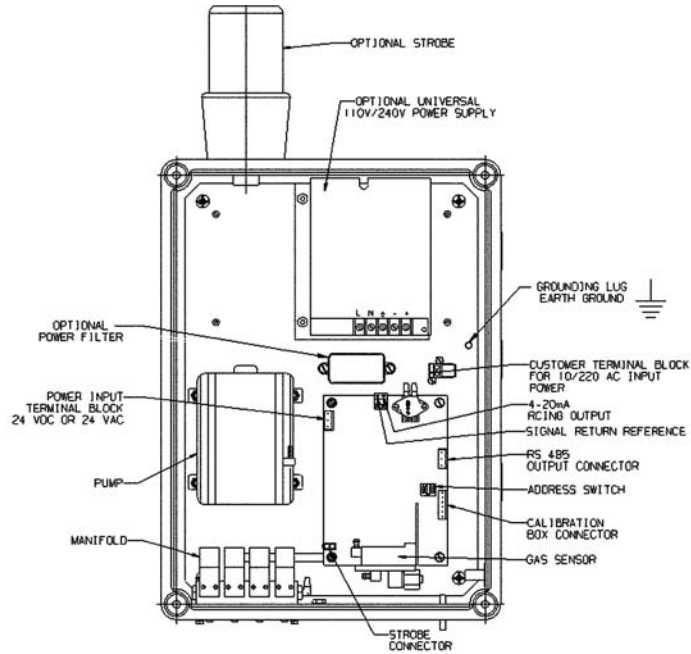

Figure 2-4. Four-Point Pumped Style Electrical Connections

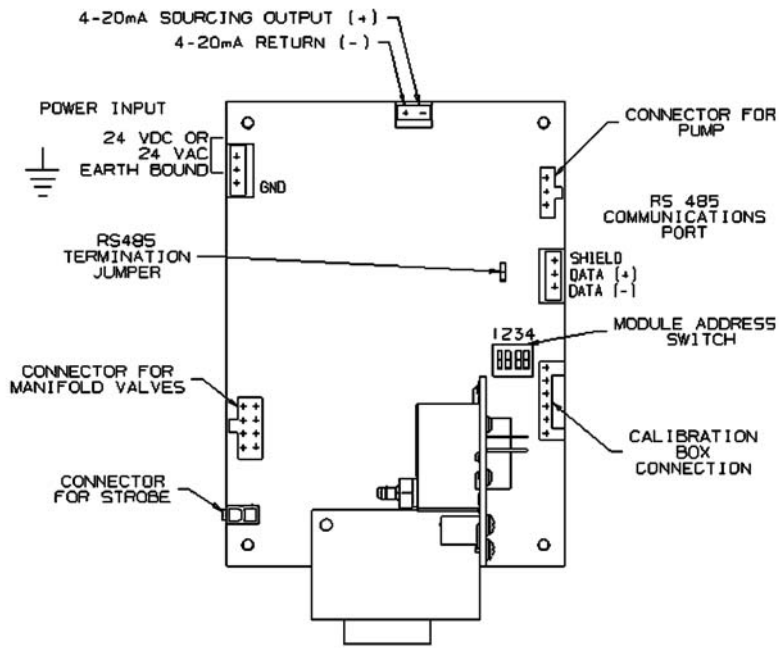

Figure 2-5. Sensor Board Connections

For 24 V DC or AC Wiring

NOTE: The 24-volt power source used with this equipment must be separated from mains by double or reinforced insulation.

All power wiring is connected to the terminal block for 24 V DC/AC input shown in FIGURE 2-5.

For 110/220 VAC Wiring

All power wiring is connected to the two-position terminal block shown in FIGURES 2-3 or 2-4.

2. Connect the "HOT" AC wire to the terminal with the black wire (or brown wire for instruments with a line filter).
3. Connect the "NEUTRAL" AC wire to the terminal with the white wire (or blue wire for instruments with a line filter).

4. Connect a ground wire on the ground stud (FIGURE 2-4). Supply earthground is installed on lug first, and all component earthgrounds are connected afterward.
5. Route the power wiring and the ground wire through electrical entry holes in the case bottom.

NOTE: Separate power wiring from output signal wiring.

The 24-volt power source used with this equipment must be separated from mains by double or reinforced insulation.

Analog Signal Output Wiring

The Chillgard LS Refrigerant Monitor is factory-configured with an analog output. The analog output for your Chillgard LS Refrigerant Monitor (FIGURE 1-1) is 4-20 mA, current sourcing type (standard) (4 mA = 0 ppm gas, 20 mA = 1000 ppm gas).

The output connections are located on the sensor board. Terminals (+) and (-) are available for the signal output and ground (FIGURE 2-3).

Chapter 3 Start-up and Initial Adjustments

Operation

This section describes the following procedures for Chillgard LS Refrigerant Monitor operation:

- Startup procedures
- Placing the system into operation
- Initial instrument calibration.

Start-Up

The following steps outline the procedures to power ON the Chillgard LS Refrigerant Monitor:

1. Before applying power to the unit, verify proper power will be applied to the unit.
2. Turn the instrument ON at the circuit breaker or fuse that supplies power to the instrument. (The instrument does not have a power switch.)

NOTE: A green LED indicates that power is ON.

After power ON, allow for unit stabilization (about two hours) before checking calibration of instrument.

General Calibration (All Models)

Introduction

The calibration procedure should be performed regularly and a log kept of calibration adjustments. Increase the calibration frequency when any calibration differs as much as 10% from the test concentration. More frequent calibrations may be required when the Chillgard LS Refrigerant Monitor is new. Calibration frequency depends on the operating time and chemical exposures of the instrument.

Also perform the calibration procedure when installing or changing the power source of the control instrumentation.

If this calibration procedure cannot be performed at any step:

- See Section 5, "Troubleshooting"
- Localize the problem
- Replace the inoperative component.

Calibrate newly installed instruments on a frequency until calibration records prove instrument stability. Calibration frequency is then reduced in accordance with a schedule established by the safety officer or facility manager.

Chapter 4 Calibration

Diffusion Version Calibration

Calibration Equipment - (FIGURE 4-1)

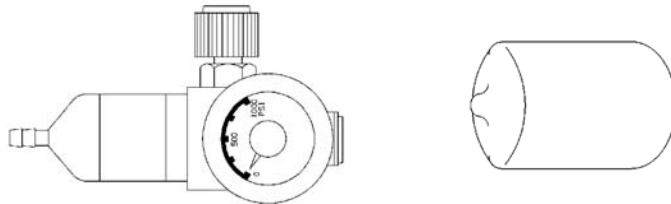

0.25 LPM Flow Controller P/N 478359

Calibration Adapter P/N 10034395

Figure 4-1. Calibration Equipment

Calibration of the monitor requires a supply of:

- **ZERO GAS** (air or nitrogen) It may be possible to use ambient air if you are sure it does not contain any possible interferant gases or contaminants.
- **SPAN GAS** (A known refrigerant concentration) that measures approximately 10% of the full-scale calibration of the unit. See TABLE 5-2 for available refrigerant gas cylinders.

Relative humidity may have a small effect on the output of the unit. If dry gas is used, Nafion Tubing (P/N 813628) can be used to humidify the sample stream going to the monitor.

Both ZERO gas and SPAN gas must be carefully applied to the unit to avoid pressurizing the internally mounted optical bench. See TABLE 5-2, Calibration Accessories Parts List for the appropriate calibration parts and calibration gases available for the Chillgard LS Refrigerant Monitor.

⚠ WARNING

Exercise care during the span calibration to ensure that the unit can accurately detect refrigerant gas. Improper calibration can cause improper readings across the full-scale range of the monitor.

Initial Calibration Procedures

During the initial calibration procedures, alarm relays of any connected control instrumentation may activate. Disconnect or disable any equipment or alarms.

The following equipment is required for initial calibration:

- Tubing Assembly with calibration adapter (FIGURE 4-1)
- Calibration Gas
- Flow Controller (0.25 LPM) (FIGURE 4-1)
- Meter capable of monitoring the output in milliamps
- Calibration box (P/N 10035292)
- Nafion[®] Tubing (P/N 813628) (optional).

Preparation for Calibration

To verify the instrument is operating properly and to make initial calibration adjustments, perform the following:

1. Remove the light gray cover to open the enclosure.

⚠ CAUTION

Do not remove the cover unless the instrument is protected from splashing, spraying, or dripping water; otherwise, damage to the internal components may result.

2. Deactivate the equipment connected to the outputs, or disconnect the wiring to the outputs.

⚠ CAUTION

If any control instruments connected to the Chillgard LS Refrigerant Monitor are wired to external devices (e.g., horns, exhaust fans, and fire suppression systems), these devices may activate while adjustments or repairs are performed during the following procedures.

To prevent activating these devices while adjusting the Chillgard LS Refrigerant Monitor, disconnect the wiring from the relay. Return all wiring to the relay when the calibration procedure is completed.

Initial Calibration

1. Using the tubing and calibration adapter, place zero gas on the unit for a minimum of five minutes as shown in FIGURE 4-2.

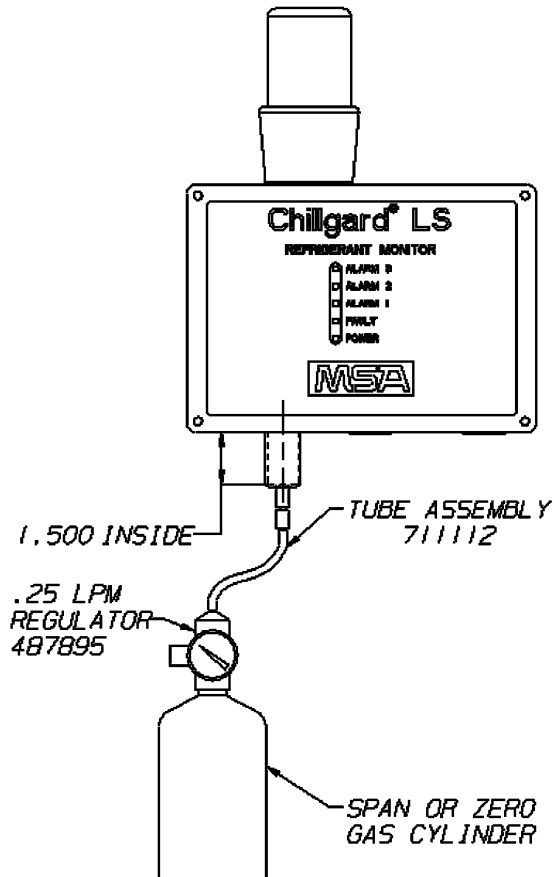

Figure 4-2.
Applying Calibration Gas
to the Chillgard LS Refrigerant Monitor

2. Using a multimeter to read the 4-20 mA output, use the Calibration Box to move the zero up or down, until the unit output reads 4 mA ± 0.1 mA with the zero gas applied.
3. Close the regulator valve and remove the zero gas cylinder from the sample tubing.
4. Apply span gas to the unit for a minimum of five minutes.
5. Using a multimeter to read the 4-20 mA output, use the Calibration Box to move the span up or down, until the unit output reads 5.6 ± 0.1 mA with the 100 ppm span gas applied.

6. Close the regulator valve and remove the span gas cylinder from the sampling tubing.
7. Remove the calibration cap and the calibration box from the unit to return to normal operation.
8. Replace lid on the enclosure.

Calibration Guidelines

Once the Chillgard LS Refrigerant Monitor is operating, perform periodic calibration checks to ensure proper instrument operation.

Perform calibration to monitor long-term changes (drift) in both the ZERO and SPAN readings. If there is an unacceptable change in either of these readings, make adjustments to obtain proper readings.

When routine calibration does not restore proper readings, perform the procedures outlined under "Initial Calibration."

If following Calibration procedures fails to restore proper readings of the instrument, see Section 5, "Troubleshooting Guidelines" for guidelines to correct the instrument.

Keep written records of the calibration readings obtained and any adjustments made. Analysis of these records enables review and control of the time between checks.

Check a new Chillgard LS Refrigerant Monitor installation at least once a week by performing the steps outlined in the following section.

Calibration Equipment

Calibration of the monitor requires a supply of:

- **ZERO GAS** (nitrogen) It may be possible to use ambient air if you are sure it does not contain any possible interferant gases or contaminants.
- **SPAN GAS** (A known gas concentration that measures approximately 10% of the full-scale calibration of the unit.

Carefully apply both ZERO gas and SPAN gas to the unit to avoid pressurizing the internally mounted sensing cell. See TABLE 5-2, "Calibration Accessories Parts List" for the appropriate calibration parts and calibration gases available for the Chillgard LS Refrigerant Monitor.

The following equipment is required to calibrate the unit:

- Calibration Gas
- Meter capable of monitoring the output, in milliamps.

Calibration Check Procedure

The calibration procedure involves checking the SPAN and ZERO readings on the instrument.

During the calibration check procedure, any control instrumentation connected to the Chillgard LS Refrigerant Monitor may activate. Disconnect or disable any equipment or alarms connected to the monitor during the calibration procedure.

Applying Calibration Gases to the Instrument

Arrange Span and Zero gas cylinders with regulator, tubing, and cal cap as shown in FIGURE 4-2.

1. Connect the mA current meter to the instrument output, terminals (+) and (-).

CAUTION

During calibration, the Chillgard LS Refrigerant Monitor is not sampling and monitoring the intended area. Exercise caution in the area as appropriate.

2. Connect the ZERO gas cylinder to the sample tubing.
3. Open the regulator valve to allow the ZERO gas to flow freely to the instrument. Supply the instrument with gas for at least five minutes. If the reading on the multimeter differs significantly from the zero (4.0 mA) reading obtained during the initial calibration procedure, perform the "Initial Calibration" procedure again.
4. Close the regulator valve and remove the ZERO gas cylinder from the sample tubing.
5. Connect the 100 ppm gas cylinder to the sample tubing.
6. Open the regulator valve to allow the SPAN gas to flow freely to the instrument. Supply the instrument with gas for at least five minutes. If the reading on the multimeter differs significantly from 100 ppm (5.6 mA), perform the "Initial Calibration" procedure again.
7. Close the regulator valve and remove the SPAN gas cylinder from the sample tubing.
8. Remove tubing and calibration cap from the sensing cell on the unit.

9. Re-connect or enable all equipment and alarm devices connected to any control equipment monitoring the Chillgard LS Refrigerant Monitor.
10. Reinstall the light gray cover.

⚠ CAUTION

Do not leave any alarm device or equipment disabled or disconnected during normal operation of the instrument; otherwise, the instrument will not function as intended when it detects an alarm situation.

Four-Point Pumped Version Calibration

Introduction

As with any type of gas monitor, the only true check of its performance is to apply gas directly to the sensor. The frequency of the calibration gas test depends on the operating time and exposures of the sensors. New monitors should be calibrated more often until the calibration records prove stability. The calibration frequency can then be reduced to the schedule set by the safety officer or plant manager.

Perform the calibration procedure regularly and maintain a log of calibration adjustments. Calibration frequency may increase for a variety of reasons. If calibration cannot be performed at any step, STOP; consult MSA at 1-800-MSA-INST.

Calibration Equipment

Equipment needed:

- Calibration Kit (MSA ATO #50; FIGURE 4-3)
- A SPAN gas cylinder
- Optional ZERO gas cylinder.
 - A ZERO gas cylinder may not be needed.

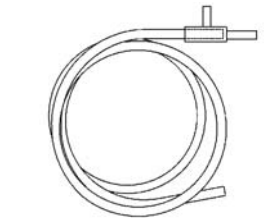

*Tube and Tee Assembly
(P/Ns 603806 and 636866)*

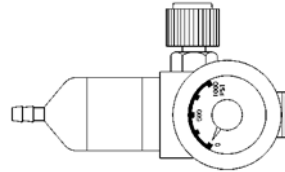

1.5 LPM Flow Controller (P/N 478358)



Connector Assembly (P/N 711533)

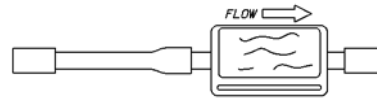

*Span Gas Scrubber (P/N 803874)
(Replace protective caps after use.)*

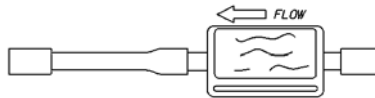

*Zero Gas Scrubber (P/N 803873)
(Replace protective caps after use.)*

Figure 4-3. Kit Components

The Calibration Kit contains a ZERO gas scrubber which can be used in place of a ZERO gas cylinder if the ambient air around the Chillgard LS contains little or no refrigerant.

Relative humidity may have a small effect on the output of the unit. If dry gas is used, Nafion Tubing (P/N 813628) can be used to humidify the sample stream going to the monitor.

⚠ CAUTION

The zero gas scrubber must be replaced periodically. The frequency of replacement depends on the concentration of the ambient refrigerant vapors.

The SPAN or ZERO cylinders (if needed) may be included with the Calibration Kit; cylinders shown in TABLE 4-1 are available from MSA.

Table 4-1. RP Calibration Gases

DESCRIPTION	CONCENTRATION	PART NO.
R-11 in Nitrogen	100 ppm	803499
R-12 in Nitrogen	100 ppm	804866
R-123 in Nitrogen	100 ppm	803498
R-134A in Nitrogen	100 ppm	803500
R-22 in Nitrogen	100 ppm	804868

Become familiar with the Calibration Kit components (FIGURE 4-3).

⚠ WARNING

Exercise care during the span calibration to ensure that the unit can accurately detect refrigerant gas. Improper calibration can cause improper readings across the full-scale range of the monitor.

Calibration Procedures

Preparation for Calibration

To verify the instrument is operating properly and to make initial calibration adjustments, perform the following:

1. Remove the light gray cover to open the enclosure.

⚠ CAUTION

Do not remove the cover unless the instrument is protected from splashing, spraying, or dripping water; otherwise, damage to the internal components may result.

2. Deactivate the equipment connected to the outputs, or disconnect the wiring to the outputs.

⚠ CAUTION

If any control instruments connected to the Chillgard LS Refrigerant Monitor are wired to external devices (e.g., horns, exhaust fans, and fire suppression systems), these devices may activate while adjustments or repairs are performed during the following procedures.

To prevent activating these devices while adjusting the Chillgard LS Refrigerant Monitor, disconnect the wiring from the relay. Return all wiring to the relay when the calibration procedure is completed.

Before calibrating the Chillgard Monitor, leak-check the sample line(s) connected to the monitor:

1. Temporarily block the sample inlet at the end-of-line filter(s) and verify that the monitor gives a Fault alarm.
2. After checking for leaks, remove the sampling line for the Chillgard inlet.
3. Attach the Calibration Kit connector assembly to the inlet.

Initial Calibration

1. Using the tubing and calibration adapter, place zero gas on the unit (FIGURE 4-4 or FIGURE 4-5). Allow five minutes for a stable reading.
2. Using a multimeter to read the 4-20 mA output, use the Calibration Box to move the zero up or down, until the unit output reads 4 mA \pm 1 mA with the zero gas applied.
3. Close the regulator valve and remove the zero gas from the sampling tubing.
4. Apply 100 ppm span gas to the unit for a minimum of five minutes (FIGURE 4-6).
5. Using a multimeter to read the 4-20 mA output, use the Calibration Box to move the span up or down, until the unit output reads 5.6 \pm 1 mA with the 100 ppm span gas applied.
6. Close the regulator valve and remove the span gas from the sampling tubing.
7. Remove all calibration accessories from the unit to return to normal operation.

Calibration Guidelines

Once the Chillgard LS Refrigerant Monitor is operating, perform periodic calibration checks to ensure proper instrument operation.

Perform calibration to monitor long-term changes (drift) in both the ZERO and SPAN readings. If there is an unacceptable change in either of these readings, make adjustments to obtain proper readings.

When routine calibration does not restore proper readings, perform the procedures outlined under "Initial Calibration."

If following Calibration procedures fails to restore proper readings of the instrument, see Section 5, "Troubleshooting Guidelines" for guidelines to correct the instrument.

Keep written records of the calibration readings obtained and any adjustments made. Analysis of these records enables review and control of the time between checks.

Check a new Chillgard LS Refrigerant Monitor installation at least once a week by performing the steps outlined in the following section.

Calibration Equipment

Calibration of the monitor requires a supply of:

- **ZERO GAS** (nitrogen) It may be possible to use ambient air if you are sure it does not contain any possible interferant gases or contaminants.
- **SPAN GAS** (A known gas concentration that measures approximately 10% of the full-scale calibration of the unit.

Carefully apply both ZERO gas and SPAN gas to the unit to avoid pressurizing the internally mounted sensing cell. See TABLE 5-2, "Calibration Accessories Parts List" for the appropriate calibration parts and calibration gases available for the Chillgard LS Refrigerant Monitor.

The following equipment is required to calibrate the unit:

- Calibration Gas
- Meter capable of monitoring the output, either milliamps or volts.

Calibration Check Procedure

The calibration procedure involves checking the SPAN and ZERO readings on the instrument. During the calibration check procedure, any control instrumentation connected to the Chillgard LS Refrigerant Monitor may activate. Disconnect or disable any equipment or alarms connected to the monitor during the calibration procedure.

Zeroing the Monitor

When zero gas is required, attach a zero gas scrubber or zero gas cylinder to the connector as shown in FIGURES 4-4 and 4-5.

⚠ WARNING

If the sampling line is not re-attached, the monitor cannot sample from the remote location.

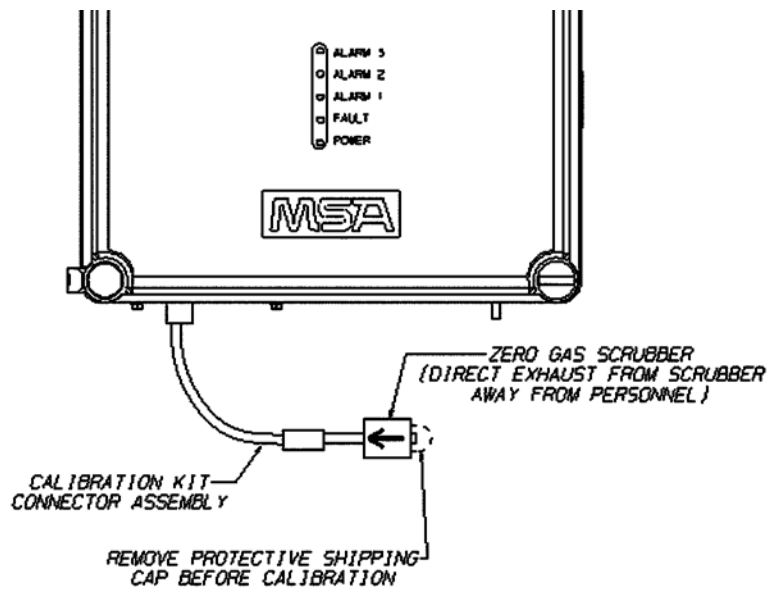

Figure 4-4. Using Zero Scrubber for Zero Calibration

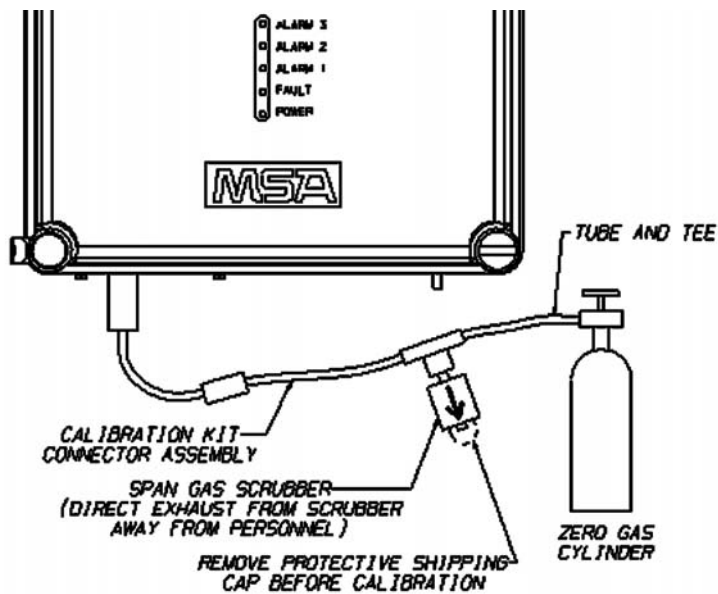

Figure 4-5. Using Zero Gas Cylinder for Zero Calibration

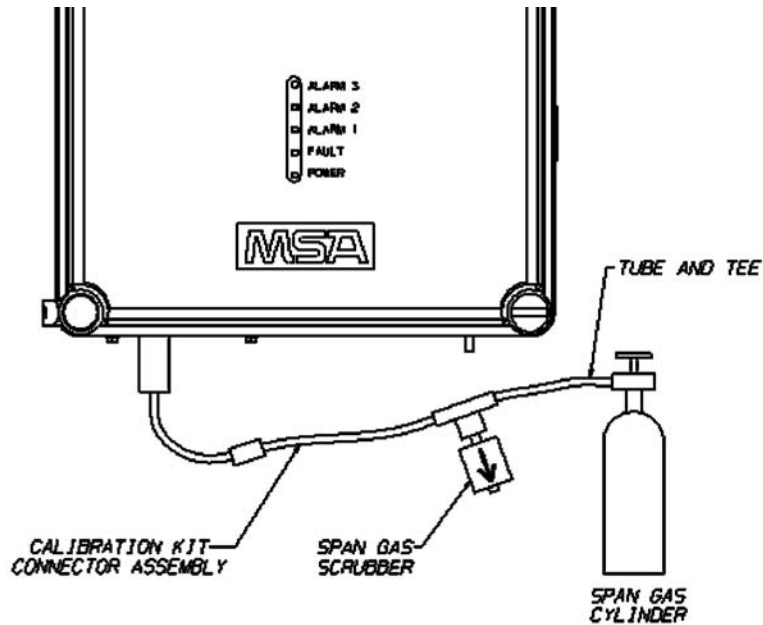

Figure 4-6. Span Calibration

1. Connect the mA current meter to the instrument output, terminals (+) and (-).

⚠ CAUTION

During calibration, the Chillgard LS Refrigerant Monitor is not sampling and monitoring the intended area. Exercise caution in the area as appropriate.

2. Connect the ZERO gas cylinder (if used) to the sample tubing.
3. Open the regulator valve to allow the ZERO gas to flow freely to the instrument. Supply the instrument with gas for at least five minutes. If the reading differs significantly from zero (4.0 mA), perform the "Initial Calibration" procedure again.
4. Close the regulator valve and remove the ZERO gas cylinder from the sample tubing.
5. Connect the 100 ppm SPAN gas cylinder to the sample tubing. Ensure the tee is located between the cylinder and the sensing cell.

6. Open the regulator valve to allow the SPAN gas to flow freely to the instrument. Supply the instrument with gas for at least five minutes. If the reading differs significantly from 100 ppm (5.6 mA), perform the "Initial Calibration" procedure again.
7. Close the regulator valve and remove the SPAN gas cylinder from the sample tubing.
8. Remove tubing from the sensing cell on the unit.
9. Re-connect or enable all equipment and alarm devices connected to any control equipment monitoring the Chillgard LS Refrigerant Monitor.
10. Reinstall the light gray cover.

⚠ CAUTION

Do not leave any alarm device or equipment disabled or disconnected during normal operation of the instrument; otherwise, the instrument will not function as intended when it detects an alarm situation.

Chapter 5 Service and Replacement Parts

Troubleshooting Guidelines

The Chillgard LS Refrigerant Monitor is designed to provide long and trouble-free monitoring.

If repairs are indicated, it is possible the user can diagnose and correct the problem using the following:

- Troubleshooting Guidelines (TABLE 5-1)
- Accessories Parts Lists (TABLE 5-2)
- Replacement Parts List

Table 5-1. Troubleshooting Guidelines

SYMPTOM	SOLUTION
No Output/ Power LED does not Light	Check and correct input power.
	Check wiring.
	Replace power supply.
	Replace LED board
Beacon will not Light When in Alarm 3	Check that plug is connected to circuit board
	Replace beacon assembly
No Analog Output	Check connection on board to 4-20 mA output
	Check board output with meter
	Replace circuit board
No RS-485 Communication	Check connection and polarity on board to RS-485 output
	Check and correct dip switch address and repower unit
	Replace circuit board
Calibration Box Does Not Communicate with Unit	Check connection to circuit board
	Replace calibration box

Table 5-1. Troubleshooting Guidelines (cont.)

SYMPTOM	SOLUTION
Noisy Output	Check input power
	Check tubing connection between optical bench and sound dampening element
	Replace optical bench
Calibration has Significantly Changed from Previous Reading	Check that gas is properly applied
	Clear inlet of particle matter
	Replace optical bench
Pump Not Running	Cycle the power and observe the pump; the FAULT light should be OFF
	Replace pump and cycle power; FAULT light should be OFF
	Replace the circuit board
FAULT Light Turns ON	Check the IR bench lamp; it must be flashing
	Replace optical bench
	For the unit equipped with pump, check the in-line filter, check tubing for leaks, and check for adequate flow rate
	Check if pump is electronically connected
	Check if pump is running
	Remove tubing from inlet and outlet
	Check if Sequencer manifold (if applicable) is electronically connected
	Check if the inlet line or filters are blocked

***▲ WARNING: Exercise caution as potential shock hazard exists**

Table 5-2. Calibration Accessories Parts List

COMPONENT/ASSEMBLY	PART NO.
REFRIGERANT CALIBRATION GAS (IN AIR)	
100 ppm R123	803498
100 ppm R11	803499
100 ppm R12	804866
100 ppm R22	804868
100 ppm R134a	803500
ZERO Air	801050
Calibration Box	10035292

Table 5-3. Replacement Parts List

COMPONENT/ASSEMBLY		PART NO.
Diffusion R-11	Optical Bench	10052377
Diffusion R-12	Optical Bench	10052378
Diffusion R-22	Optical Bench	10052379
Diffusion R-123	Optical Bench	10052380
Diffusion R-134 A	Optical Bench	10052421
Diffusion Sound Dampening Element		10032706
Calibration Cap		10034395
Power Supply		10034190
Power Filter		10034402
Diffusion Sensor PCB Assembly		10031467
LED Display		10039025
LED Cable Assembly		10034517
Four-Point Manifold Assembly		10033554
Strobe		634674
External Filter		711561
Pump Sound Dampening Element		10037529
Pump		10037963
Pumped Sensor Printed Circuit Board Assembly		10035346
Pumped R-11 Optical Bench		10052422
Pumped R-12 Optical Bench		10052423
Pumped R-22 Optical Bench		10052424
Pumped R-123 Optical Bench		10052425
Pumped R-134 A Optical Bench		10052426
In-Line Filter		10037357
Tubing Assembly		10037896
Pressure Sensor		10032335

Service and Assistance

When ordering replacement parts or to obtain assistance regarding any problem with the Chillgard LS Refrigerant Monitor, please provide the following information (found on a label located on the side of the instrument):

- serial number
- model number.

To obtain parts and/or assistance, contact the nearest MSA representative or write or call:

**Mine Safety Appliances Company
Sales Department
P.O. Box 427, Pittsburgh, PA 15230**

1-800-MSA-INST.

Appendix A Installation Outline Drawings

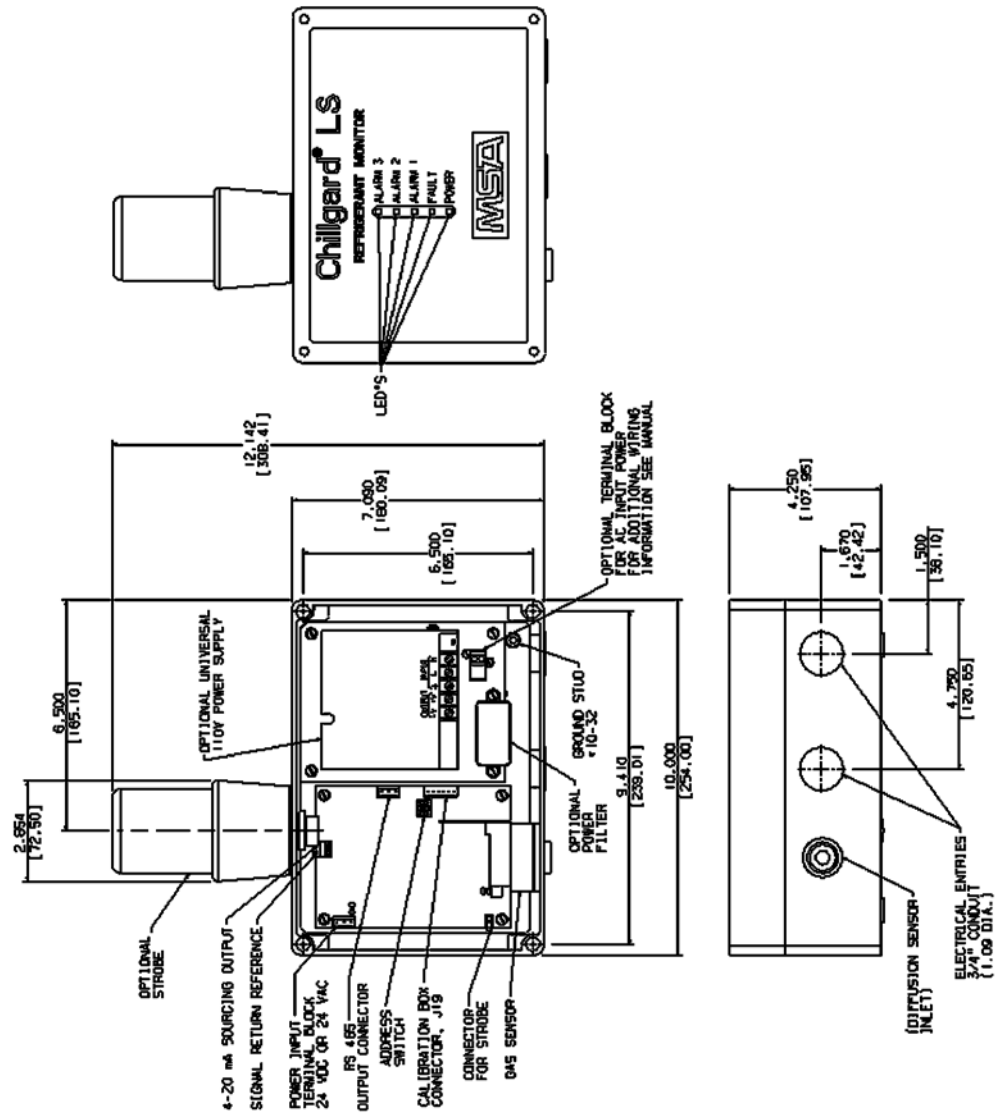

Figure A-1. Diffusion Style Chillgard LS Installation Drawing

**For Four-Point Pumped Style Chillgard LS Unit,
see:**

- **Mounting Dimensions** given in FIGURE 2-2
- **Electrical Connections** given in FIGURE 2-4.

Appendix B RS-485 Output

The sensor module uses an RS-485 serial interface with Modbus protocol. To communicate to the RS-485 output via a computer interface, an isolated RS-485 converter (such as P/N 10014359) should be used. The baud rate is 19,200 baud with RTU format sent. Each byte has eight bits with no parity and two stop bits. Each exchange has a two-byte CRC 16 check value.

The sensor unit has an ID range of 100 - 107. The dip switch positions 1 through 3 are binary encoded and read on startup.

Table B-1. Dip Switch Positions

ID	DIP SWITCH			
	1	2	3	4
100	0	0	0	-- *
101	1	0	0	--
102	0	1	0	--
103	1	1	0	--
104	0	0	1	-- *
105	1	0	1	--
106	0	1	1	--
107	1	1	1	--

NOTE: 1 indicates closed.

* indicates valid address for a four-point pumped unit.

Two functions are supported:

- Read Holding Registers - Function #3
- Preset Multiple Registers - Function #16

Table B-2. Sensor Unit Register Addresses

TITLE	REGISTER ADDRESS	READ/ WRITE	DEFINITION OF ENCODED DATA	
Fault & Module State	40001	R	Cal Sum	1 msb
			Under Range	2 msb
			Flow Loss	4 msb
			Under Voltage	8 msb
			Temperature	10 msb
			Prog Cksum	20 msb
			Lamp Fail	40 msb
			Warm Up	0 lsbJ
			Normal	1 lsb
			Cal/Setup	2 lsb
			Factory	4 lsb
			Trouble	8 lsb
			Gas Number	40002
Gas Concentration	40003	R	-20 to 1050	
Alarm State	40004	R	None	0 lsb
			Caution	1 lsb
			Warning	2 lsb
			Alarm	3 lsb
Module Zero	40006	R/W	-100 to 100	
Module Span	40007	R/W	500 to 2000	
Analog Range	40010	R/W	10 or 100% full scale	
MA Zero	40011	R/W	0 to 1000	
MA Span	40012	R/W	1000 to 3000	
Caution Level	40013	R/W	30 to 980	
Warning Level	40014	R/W	40 to 990	
Alarm Level	40015	R/W	50 to 1000	