

FOR DAISY-CHAIN (SERIES) WIRING OF ZGARD S SENSORS TO THE ZGARD C8P CONTROLLER AS SHOWN HERE, EACH SENSOR MUST BE UNIQUELY ADDRESSED VIA JUMPERS ON SENSOR CIRCUIT BOARD.

CABLE LENGTH FEET	No. OF SENSORS	4	6	8
1 TO 500	AWG #	22	22	22
501 TO 1,000	AWG #	22	20	20
1,001 TO 1,500	AWG #	20	18	18
1,501 TO 2000	AWG #	18	16	16

GAUGE (AWG#)	4-WIRE SHIELDED CABLE
22	ALPHA WIRE 5504
20	ALPHA WIRE 5514
18	ALPHA WIRE 5524
16	ALPHA WIRE 5534

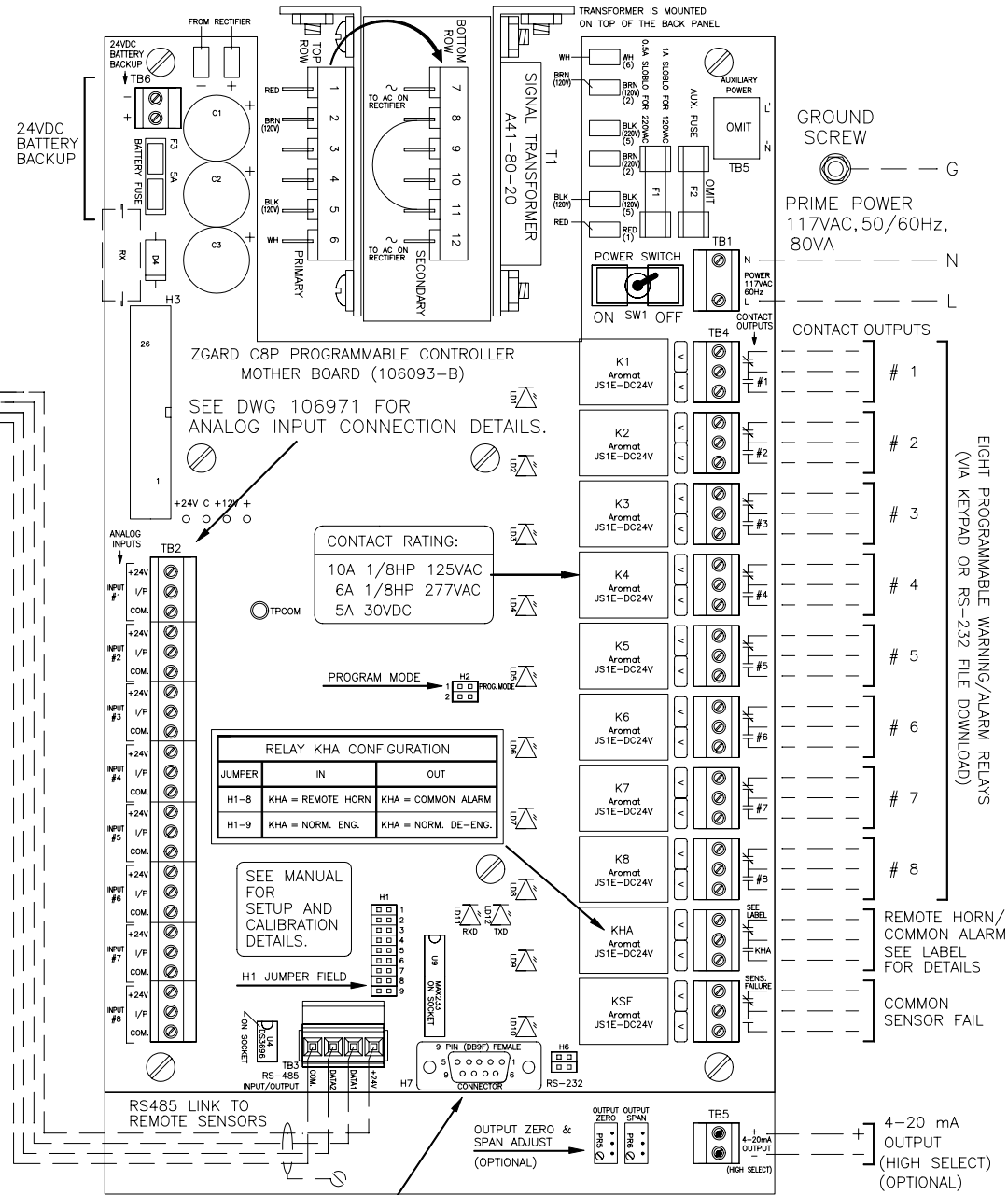
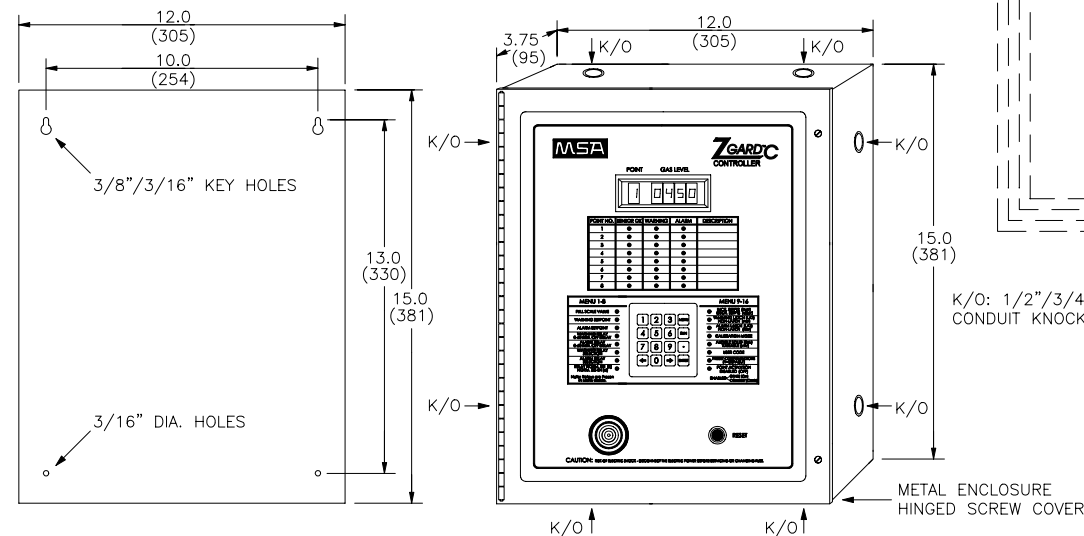

- NOTES:
- DIMENSIONS SHOWN IN INCHES (MILLIMETERS).
  - SYSTEM MAY CHANGE TO IMPROVE PERFORMANCE.

MSA

CHKD:	DATE: Feb. 02/05	DRN: KS
ZGARD C8P Programmable Controller Installation Outline for RS-485 Digital Signal Type Sensors		
DWG. NO.:	106972	REV. A