



Photoionization Detectors (PIDs)

[Theory, Uses and Applications for First Responders, Law Enforcement Agents, HazMat and Fire Service Professionals]

Photoionization Detectors (PIDs)

For years, fire departments, law enforcement agents, HazMat teams, and now more than ever First Responders, have been concerned about detecting and identifying hazardous compounds in emergency situations. Several techniques and technologies are used such as:

- Catalytic sensors
- Electrochemical sensors
- Gas chromatography
- Flame ionization
- Photoionization
- Ion Mobility Spectrometry
- Surface Acoustic Wave
- Color-changing detectors

While each of the above technologies have their advantages, photoionization detectors offer the ideal combination of speed-of-response, ease-of-use and maintenance, size, ability to detect low levels (in the ppm range) of many hazardous compounds, and affordability. PIDs are capable of effectively detecting and monitoring several hundred, if not thousands, of hazardous substances for maximum benefits and safety to users.

What Does Ionization Mean?

When the gas being sampled absorbs the energy from the PID lamp, it becomes “excited” and its molecular content is altered. The compound loses an electron (e-) and becomes a positively charged ion. Once this happens, the substance is considered to be “ionized.” This is what happens inside the PID.

Pictorially, we see photoionization at work in Figure 1.

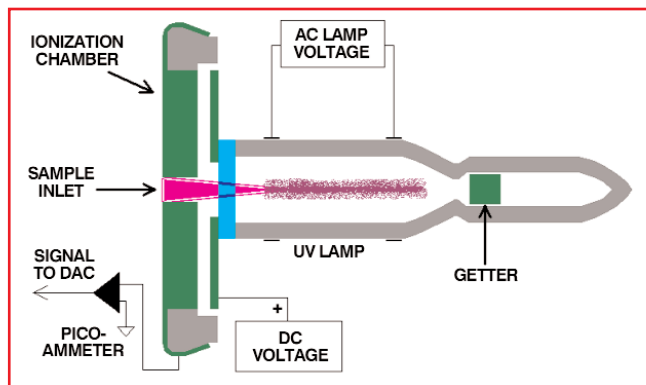

Figure 1. Block diagram of photoionization at work.

Theory of Operation

PIDs rely on ionization as the basis of detection. Most substances can be ionized; some more easily than others. The ability of a substance to be ionized is measured on an eV (electron volt) energy scale. The scale generally runs from a value of 7 to a value of approximately 16. Substances with an eV rating of 7 are very easy to ionize. Substances with an eV rating between 12 and 16 are extremely difficult to ionize. The eV ratings of some common substances include:

Substance	eV	Substance	eV
Benzene	9.24	Methyl ethyl ketone (MEK)	9.53
Hexane	10.18	Chlorine Dioxide	10.36
Toluene	8.82	Phosphine	9.87
Styrene	8.41	Ammonia	10.18

When chemicals being monitored have been ionized inside the instrument, a current is produced and the concentration of the compound is displayed as parts-per-million on the meter. PIDs utilize an ultraviolet (UV) lamp to ionize the compound to be monitored. The lamp, often the size of a common flashlight bulb, emits enough ultraviolet energy to ionize the compound.

There are different lamps available for PIDs. Two examples follow:

A 9.8 eV lamp puts out enough energy to ionize any compound whose eV rating is less than 9.6:



- Toluene 8.82 eV
- Benzene 9.25 eV
- Propylamine 8.78 eV
- Styrene 8.40 eV
- Vinyl acetate 9.19 eV

A 10.6 eV lamp puts out enough energy to ionize any compound that a 9.8 eV lamp can detect, plus any compound whose eV rating is less than 10.6.



- Propyl alcohol 10.22 eV
- Phosphine 9.96 eV
- Vinyl chloride 10.00 eV
- Acetaldehyde 10.22 eV

Substances that PIDs Can Detect

PIDs measure organic compounds such as benzene, toluene, and xylene, and also certain inorganics such as ammonia and hydrogen sulfide. As a general rule, if the compounds being measured or detected contain a carbon (C) atom, a PID can be used. However, this is not always the case, as methane (CH₄) and carbon monoxide (CO) cannot be detected with a PID.

Following are some of the common substances that a PID can detect and monitor:

- Benzene
- Toluene
- Vinyl chloride
- Hexane
- Ammonia
- Isobutylene
- Jet A fuel
- Styrene
- Allyl alcohol
- Mercaptans
- Trichloroethylene
- Perchloroethylene
- Propylene oxide
- Phosphine

Substances that PIDs Cannot Detect

PIDs cannot be used to measure the following common substances:

- Oxygen
- Nitrogen
- Carbon dioxide
- Sulfur dioxide
- Carbon monoxide
- Methane
- Hydrogen fluoride
- Hydrogen chloride
- Fluorine
- Sulfur hexafluoride
- Ozone

Response Factors

The optimal way to calibrate a PID to different compounds is by using a standard of the gas of interest. However, this is

not always practical as it requires that a number of different and sometimes hazardous gases be kept on hand for this purpose. To address this issue, response factors are used. A response factor is a measure of the sensitivity of a PID to a particular gas. With response factors, a user can measure a large number of compounds using a single calibration gas – typically isobutylene. The user simply multiplies the instrument reading (calibrated for isobutylene) by the response factor to get the corrected value for the compound of interest.

The instruction manuals for most PIDs list the response factors. Some PIDs have response factors for common gases programmed into the software of the unit so that all response factor calculations are performed automatically. If the compound at a test site is known, the instrument can be set to indicate a direct reading for the target compound.

Threshold Limit Values (TLVs) and Permissible Exposure Limits (PELs)

The default low and high alarm values are set for isobutylene. If the user wants to monitor a different gas, they must determine the TLVs for the gas and then change the instrument's alarm level accordingly. The instrument manual should be referenced to ensure correct instructions are followed. Chemical limit values can be found by referencing ACGIH, NIOSH, or OSHA.

Indicator Versus Analyzer

A common misconception about PIDs is that they are analyzers. Many expect that a PID will tell them exactly what the vapor is at a spill site. This is not true. While

PIDs are extremely sensitive and effective tools, they are not analyzers and cannot determine if the spill is benzene, jet fuel or iodine, for example. A PID can detect that something is present and can alert you to potentially hazardous situations, but additional steps will be necessary to properly identify what the substance is and how much of that substance is present.

Below is a sample procedure to identify the concentration of a substance at a spill site:

1. Set the PID to isobutylene
2. Detect and record a reading
3. Identify, via a placard or MSDS, what the specific substance is

If the placard or MSDS tells you that the substance is vinyl chloride, set the PID response factor to vinyl chloride so that you can get a direct reading of the actual vinyl chloride level.

PID Applications

Homeland Security

Potential terrorist chemical attacks may include industrial chemicals such as chlorine dioxide and ammonia. First Responders can use PIDs to confidently determine whether one of these chemicals is present and, if so, to accurately measure the concentration.

No single technology alone is adequate for First Responders to rely on completely, but PIDs used in conjunction with other tools such as SAW or IMS devices can assure that the most appropriate response is taken in a homeland security incident.

Three ways in which response factors are used with PIDs

Method	Example
<p>Method #1: Preprogrammed Response Factors</p> <p><i>Typically, PID detectors are calibrated for 100 ppm isobutylene. Other gases, for which there are hundreds, have corresponding correction values known as response factors. Numerous corresponding response factors are preprogrammed into the PID instrument. After a user selects the desired gas to measure from the instrument menu, the unit will automatically calculate the corrected gas concentration reading for the gas of interest. The direct reading will now measure the selected gas' concentration.</i></p>	<p>The instrument is calibrated to read in isobutylene equivalents, for a reading of 100 ppm with 10.6 eV lamp. Ethylbenzene is the target gas, with a response factor of 0.62. Select the pre-programmed response factor and the instrument now reads about 62 ppm when exposed to the same gas, reading directly in ethylbenzene concentration values.</p>
<p>Method #2: Customized Response Factors</p> <p><i>Typically, PID detectors are calibrated for 100 ppm isobutylene. If a user does not find a desired gas in the preprogrammed instrument menu list, the user can program a custom gas and response factor into the unit. If the user does not know the corresponding response factor, they can call MSA and request a customized response factor be calculated specific to their application.</i></p>	<p>Tetrahydrofuran is the target gas. The response factor for tetrahydrofuran is 2.1 with 10.6 eV lamp. When calibrating the instrument with 100 ppm isobutylene, enter 2.1 times 100, or 210, when prompted for the calibration gas concentration. The instrument now reads directly in tetrahydrofuran concentration values.</p>
<p>Method #3 Manually Calculated Response Factors</p> <p><i>Typically, PID detectors are calibrated for 100 ppm isobutylene. If a user chooses to read an isobutylene's direct reading for a different gas and does not want to utilize either the preprogrammed or customized response factors, the user may manually calculate the desired gas' direct reading. If the user knows the response factor of the desired gas, they can manually multiply the isobutylene reading by the known response factor. The result of this equation can be recorded externally to the instrument.</i></p>	<p>The instrument is calibrated with isobutylene to isobutylene equivalents, for a reading of 10 ppm with 10.6 eV lamp. Cyclohexanone is the target gas, with a correction factor of 0.82. Multiply 10 by 0.82 to produce an adjusted cyclohexanone concentration of 8.2.</p>

Leak Detection

Often the level of a leak is so small that it cannot be smelled by humans. PIDs are used to detect these low-level leaks. PIDs can detect compounds at levels below 1 ppm.

Not only can PIDs be used to detect leaks, they can also be used to locate sources of leaks. Higher concentrations of gases are found at or near the source of a leak. Once the user detects a substance, the user, wearing adequate personal protective equipment, should move in the direction of higher concentrations if trying to identify the source of the leak.

Perimeter Monitoring

At HazMat sites, perimeters are set to contain a hazardous area. PIDs can be used to set and, if necessary due to changing environmental conditions, change the perimeter line. For example, the concentration of toluene is 5 ppm at Perimeter Line A at 10:50 a.m. At 11:05 a.m., the reading at Line A changes to 10 ppm due to the wind direction. This tells the HazMat worker that the perimeter line may need extended.

Spill Delineation

Because water and foam are often used at HazMat sites, there can be a variety of liquids on the ground in addition to any material that was inadvertently spilled. A PID is effective in locating the hazardous substance while "ignoring" the foam and water. The PID will not respond to the water or foam.

Remediation

Often times, HazMat spills can contaminate bodies of water or soil, which poses long-term environmental concerns. PIDs are extremely useful in taking samples from soil to determine if remediation is necessary in conjunction with applicable environmental regulations.

Arson Investigation

PIDs are often used to detect accelerants at a post-fire scene. PIDs can detect low levels of substances used to accelerate fires. Once a reading is detected on the PID, a sample from that specific area can be taken to a laboratory to be analyzed. In this application, it is recommended that the PID be set to the isobutylene response factor for general-purpose indications.

Diesel Fuel TLV Monitoring

Marine chemists are now following new TLV limits for diesel fuel which have been determined by the ACGIH (American Conference of Governmental Industrial Hygienists). The presence of diesel fuel in the workplace and its associated exhaust has long been connected with being carcinogenic and a source of particulate pollution associated with lung disease. The new TLV is 15 ppm of diesel vapor. This is very conservative, and all marine chemists are expected to comply with this new TLV. Sampling for diesel fuel vapors and recording the results are important aspects of their inspections. Surveys are conducted in fuel tanks, cargo spaces and engine rooms.

Determining the Level of Personal Protective Equipment (PPE) Required

One of the most fundamental questions at a potential HazMat incident is, "What type of PPE should be used?" Is the site truly hazardous? Is Level A clothing or self-contained breathing apparatus (SCBA) necessary throughout the whole incident? A PID can help determine appropriate levels of PPE.

Decontamination

After the incident is over, PIDs can be used to help determine if any of the HazMat responders need to be decontaminated by checking the protective clothing for contamination. This can help HazMat teams decide if they can reuse a piece of clothing rather than discarding it – allowing a potentially significant cost savings to the HazMat team.

Conclusion

PIDs are extremely valuable tools for Homeland Security, Law Enforcement Agents, Fire Service and HazMat response. Their sensitivity, low levels of detection, and ability to detect many different compounds enable PIDs to be used in many different applications. Simply stated, PIDs can help make the difficult jobs of First Responders, Law Enforcement Agents, Fire Service and HazMat professionals easier.

Note: This Bulletin contains only a general description of the products shown. While uses and performance capabilities are described, under no circumstances shall the products be used by untrained or unqualified individuals and not until the product instructions including any warnings or cautions provided have been thoroughly read and understood. Only they contain the complete and detailed information concerning proper use and care of these products.

ID 0803-11/January 2004

©MSA 2004 Printed in U.S.A.



Corporate Headquarters:
P.O. Box 426, Pittsburgh, PA 15230 USA
e-mail info@MSAnet.com
www.MSAnet.com
www.MSAfire.com

U.S. Customer Service Center:
Phone 1-800-MSA-2222
Fax 1-800-967-0398

MSA Canada:
Phone 1-800-MSA-2222
Fax 905-238-4151

MSA Mexico:
Phone 52-55 2122-5770
Fax 52-55 359 4330

MSA International:
Phone (412) 967-3354
Fax (412) 967-3451

Offices and representatives worldwide

For more information:

