



Tankscope[®] Combustible Gas Indicator Model 62T

Instruction Manual

WARNING

THIS MANUAL MUST BE CAREFULLY READ BY ALL INDIVIDUALS WHO HAVE OR WILL HAVE THE RESPONSIBILITY FOR USING OR SERVICING THE PRODUCT. Like any piece of complex equipment, the Tankscope Model 62T will perform as designed only if it is used and serviced in accordance with the manufacturer's instructions. OTHERWISE IT COULD FAIL TO PERFORM AS DESIGNED AND PERSONS WHO RELY ON THIS PRODUCT FOR THEIR SAFETY COULD SUSTAIN SEVERE PERSONAL INJURY OR DEATH.

The warranties made by Mine Safety Appliances Company with respect to the product are voided if the product is not used and serviced in accordance with the instructions in this manual. Please protect yourself and others by following them. We encourage our customers to write or call regarding this equipment prior to use or for any additional information relative to use or repairs.

CAUTION

For safety reasons, this equipment must be operated by qualified personnel only. Read and understand the instruction manual completely before operating.

In the U.S., to contact your nearest stocking location, dial toll-free 1-800-MSA-2222. To contact MSA International, dial 1-412-967-3000 or 1-800-MSA-7777.

This manual pertains to instruments with 1000 series and higher Serial Numbers.

© MINE SAFETY APPLIANCES COMPANY 1998 - All Rights Reserved

Manufactured by
MSA INSTRUMENT DIVISION
P.O. Box 427, Pittsburgh, Pennsylvania 15230

(L) Rev 0

711291

Table of Contents

Chapter 1	
General Information	1-1
Introduction	1-1
General Description	1-1
General Specifications	1-1
Table 1-1. General Specifications	1-1
Serial Number Identification	1-2
Safety and General Limitations	1-2
▲ WARNING	1-2
GENERAL LIMITATIONS AND ▲ WARNINGS	1-2
Chapter 2	
Operation	2-1
Initial Inspection	2-1
Initial Checks	2-1
Figure 2-1. Location of Controls and Indicators	2-1
Operation	2-2
▲ CAUTION	2-3
Optional Sampling Equipment	2-4
Sampling Lines	2-4
▲ CAUTION	2-4
To Test the Atmosphere at a Remote Location:	2-4
Probes	2-4
▲ WARNING	2-5
Figure 2-2. Sampling Probe Connection	2-5
Line Trap	2-6

Section 3
Maintenance 3-1

- Periodic Maintenance 3-1
 - Instrument Cleaning 3-1
 - ▲ CAUTION 3-1
 - Sampling System Checks 3-1
 - Leak Checks 3-1
 - Figure 3-1. TC Filament Location 3-2
 - Figure 3-2. Cotton Filter Replacement 3-3
 - ▲ WARNING 3-4
- Troubleshooting 3-4
 - Table 3-1. Troubleshooting Guidelines 3-4
- Corrective Maintenance 3-6
 - TC Filament Replacement 3-6
 - Flashback Arrester Replacement 3-7
 - ▲ WARNING 3-7
 - Figure 3-3. Location of Parts in Filament Wells 3-8
 - Figure 3-4. Flashback Arrester Locations 3-9
 - Battery Replacement 3-10
 - Figure 3-5. Battery Removal 3-10
- Ordering Parts 3-11
 - Table 3-2. Parts List 3-11

Chapter 4
Calibration 4-1

- Introduction 4-1
- Calibration Procedure 4-1
 - Figure 4-1. Span Adjustment Location 4-2

Chapter 1

General Information

Introduction

This manual provides operation, maintenance and calibration information for the Tankscope® Model 62T Combustible Gas Indicator.

General Description

The Tankscope Model 62T Indicator is intended for use in shipboard oil transport applications. In this application, the instrument essentially operates in an inert atmosphere, where the inerting gases are diesel exhaust from the ship's power plant. For this application, a thermal conductivity (TC) combustible sensor is necessary for appropriate readings.

General Specifications

Table 1-1. General Specifications	
ELECTRICAL CHARACTERISTICS	
ACCURACY	Factory-calibrated to $\pm 4\%$ of full-scale on 8% Butane in an inert gas of 15% CO ₂ and 85% N ₂
POWER SUPPLY	8 carbon-zinc "D" cells (Eveready 950, Burgess 800, or equivalent)
POWER SUPPLY LIFE	24 hours minimum continuous usage with fresh batteries at normal ambient temperature
RANGE	0 to 25% Butane in inert background gas
PHYSICAL CHARACTERISTICS	
SAMPLE FLOW RATE	0.03 to 0.05 cfm (0.8 to 1.4 LPM)
CONSTRUCTION	Plastic case with stainless steel hardware
DIMENSIONS	6-1/2" x 7-1/4" x 4" (165 mm x 185 mm x 102 mm)
WEIGHT	5 lbs., 2 oz. (2.25 kg, 57 g)

Serial Number Identification

The Tankscope Model 62T is identified by a serial number on the inside-cover instruction label (see Chapter 2, FIGURE 2-1). Include this number with any correspondence with MSA concerning this unit.

Safety and General Limitations

▲ WARNING

The Tankscope Model 62T Indicator is an instrument of measurement without alarms. The operator must understand and monitor the readings to avoid being exposed to an explosive or unsafe atmosphere. All calibration and readings must be performed with the Tankscope Model 62T Indicator in the normal, upright position. If the unit is used in any other position, incorrect readings will result.

Changes or modifications to this unit not expressly approved by the party responsible for compliance could void the user's authority to operate the equipment.

GENERAL LIMITATIONS AND ▲ WARNINGS

The Tankscope Model 62T Indicator measures combustible gases and vapors. It cannot measure the presence of combustible:

- airborne mists such as lubricating oils
- airborne dusts such as grain or coal dust

When sampling with accessory sampling lines, the shortest possible length should be used to minimize the time needed to obtain a valid reading.

When sampling over liquids, the end of the sampling line must not touch the surface of the liquid. Otherwise, liquids may enter the instrument, causing internal damage. In addition, sample gas may be blocked from entering the line, and a false reading may occur.

Do not use MSA Lead Inhibitor Filters with this instrument. Loss of sensitivity may result.

Dispose of used batteries in accordance with local health and safety regulations.

A calibration check should be included as part of a routine inspection of this instrument to ensure it is operating properly and readings are accurate. See Chapter 4 for calibration procedure details.

Use only genuine MSA replacement parts when performing any maintenance procedures described in this manual. Substitution of components may seriously impair instrument performance, alter intrinsic safety characteristics, or void agency approvals.

Repair or alteration of the Tankscope Indicator, beyond the procedures described in this manual, could cause the instrument to fail to perform properly.

FAILURE TO FOLLOW THE ABOVE WARNINGS CAN RESULT IN SERIOUS PERSONAL INJURY OR DEATH.

Chapter 2 Operation

Initial Inspection

Remove instrument from the shipping container; if damage or shortage is noted, make the proper claim with the carrier.

Initial Checks (FIGURE 2-1)

To verify instrument operation and factory-calibration, perform the following procedure in an atmosphere free of combustible gases. If the proper indication cannot be obtained, please call our toll free number: **1-800-MSA-2222**.

To contact MSA International, please call:
1-412-967-3000 or 1-800-MSA-7777.

1. Open the cover and set the ON/OFF switch to ON.
 - READY indicator should turn ON within approximately four seconds

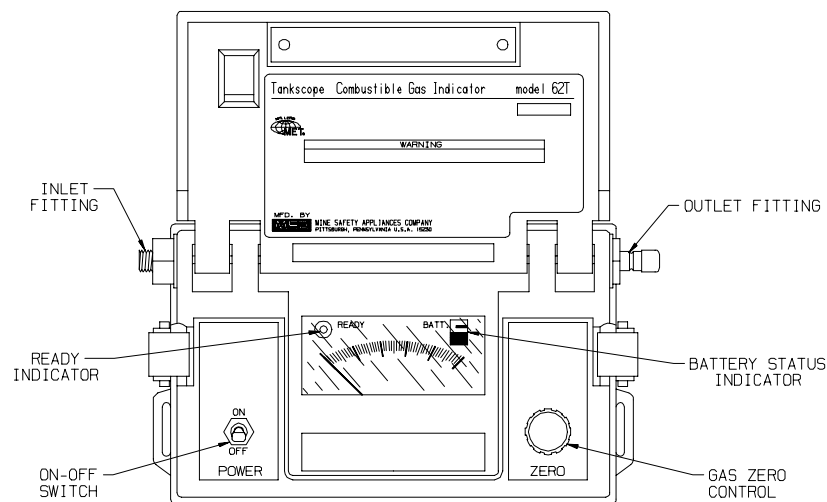

Figure 2-1. Location of Controls and Indicators

- BATT indicator pointer should be at least halfway into the white zone.
2. Squeeze the aspirator bulb eight to 10 times to purge the instrument with fresh air.
NOTE: Permit the bulb to completely inflate after each squeeze.
 3. While squeezing the aspirator bulb, lift and adjust the ZERO control to obtain a zero indication on the meter.
NOTE: To make any zero adjustments, lift and turn the outer sleeve on the ZERO control.
 4. Connect the Model R Calibration Check Kit to the calibration check gas cylinder [8% Butane, 15% CO₂ in N₂ (P/N 460345)].
 5. Connect the adapter hose between the flow control and the instrument inlet fitting.
 6. Turn the flow control valve counterclockwise to pass the gas through the instrument.
 - When the needle stabilizes, the meter should indicate between 7 and 9% Butane.
 7. Turn the valve clockwise to close.
 8. Disconnect the hose from the inlet fitting and remove the flow control from the gas cylinder.
 9. Squeeze the aspirator bulb eight to 10 times to purge the instrument with fresh air.
 10. If the meter does not indicate between 7% and 9%, perform the Chapter 4, "Calibration Procedure."

Operation (FIGURE 2-1)

To measure the concentration of the specific combustible gas for which the instrument is calibrated, perform the following:

NOTE: Leak, flow and calibration checks should be made periodically as described in Chapters 3 and 4.

1. Open the cover and set the ON/OFF switch to ON.
 - BATT indicator pointer should be well into the white zone
 - READY indicator should turn ON within approximately four seconds; if it does not turn ON, perform the Chapter 3, "Battery Replacement" procedure.

2. Squeeze the aspirator bulb eight to 10 times to purge the instrument with fresh air.

NOTE: Permit the bulb to completely inflate after each squeeze; if the bulb does not inflate within four seconds, perform the Chapter 3, "Sampling System Checks" procedure.

3. Lift and adjust ZERO control to obtain a zero indication on meter.
4. In the area to be tested, squeeze the aspirator bulb seven or eight times to draw the sample into the instrument.

- For sample line lengths up to 25 feet, 10 squeezes are recommended
- For sample line lengths between 25 and 50 feet, 15 squeezes are recommended
- When the needle stabilizes, the meter indicates the concentration (in percent by volume) of Butane in an inert background.

NOTE: Meter indications are valid only when the READY indicator is ON.

When using a sampling line, squeeze the aspirator bulb two additional times for each 10 feet of line.

When using a line trap, squeeze the aspirator bulb four additional times.

5. After the reading is taken:
 - a. Remove the probe.
 - b. Aspirate fresh air through the probe, sample line and instrument to flush out residual gas content and avoid confusion in future tests.

⚠ CAUTION

When sampling over liquids, ensure that the end of the sampling line does not touch the liquid surface. A closed-end probe tube or line trap should be used in this type of test to prevent liquid from being drawn into the instrument. Sampling dusty or smoky atmospheres may clog the flow system. If the instrument response time increases or the aspirator bulb does not inflate within two seconds, perform the Chapter 3, "Sampling System Checks" procedure.

Optional Sampling Equipment

Sampling Lines

Sampling lines permit samples to be taken at remote locations or inaccessible areas in order to test the atmosphere in areas such as:

- manholes
- sewers
- barholes.

Available sampling lines:

- range from five to 50 feet
- are made of synthetic material, specially compounded to resist absorption of combustible vapors.

⚠ CAUTION

Do not use sampling lines made of ordinary rubber or any synthetic material which absorbs solvent vapors; otherwise, the absorption will result in erroneous indications, usually lower than the actual value.

Always use the shortest possible length of sampling line to minimize the number of times the aspirator bulb must be squeezed to obtain a valid indication.

To Test the Atmosphere at a Remote Location:

1. Position the male coupling of the sampling line at the desired sampling point so that dirt particles do not clog the tube and liquids are not drawn into the instrument.
2. Connect the coupling on the other end of the line to the instrument inlet fitting (FIGURE 2-2).

NOTE: Make sure the connection is gas-tight (see Chapter 3, "Leak Checks").

- The gas concentration at the sampling point can then be measured by performing the procedure under Chapter 2, "Operation."

Probes

Probes permit samples to be taken in areas that cannot be reached with a sampling line. By connecting the probe to a

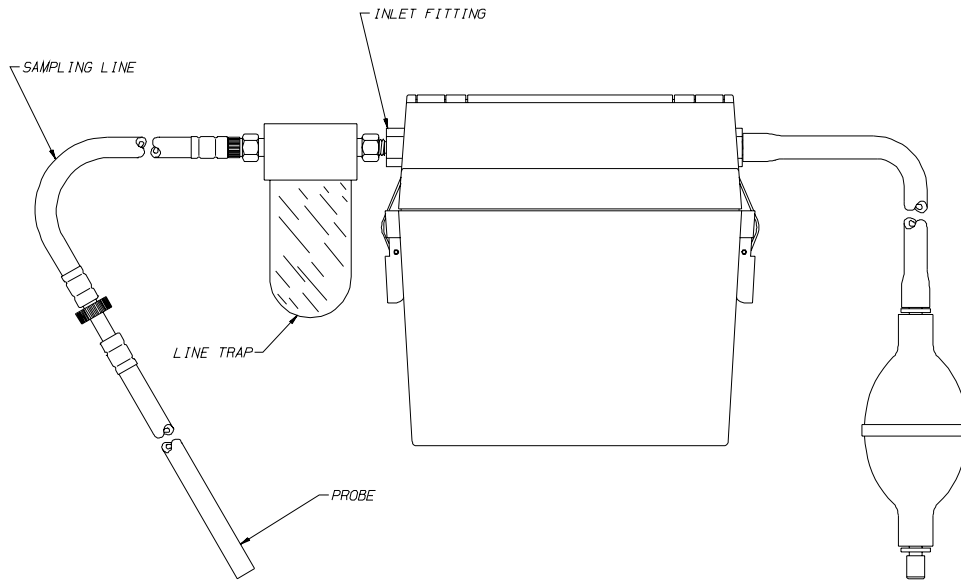

Figure 2-2. Sampling Probe Connection

sampling line, the user can examine barholes, manholes and sewers that are obstructed or accessible only through narrow openings (FIGURE 2-2).

Three probes are available for use with the Tankscope Indicator:

- four-foot, solid probe rod

[used to prevent liquids from entering the instrument if the open end of a sampling line inadvertently dips into a liquid in a tank or other vessel (see Chapter 3, TABLE 3-2)].

- three-foot, hollow-brass probe tube
- three-foot, dielectric, plastic probe tube.

⚠ WARNING

Do not use the brass probe tube where contact may be made with electrical equipment or power lines as a shock hazard exists. It is recommended to use the plastic probe tube where possibility of contact with electrical equipment or power lines exists. Using the brass probe in these situations may cause serious injury or death.

Line Trap

The line trap is primarily used to prevent liquids from being inadvertently drawn into the instrument when sampling atmospheres in tanks, sewers or sumps.

NOTE: Refer to instructions supplied with the line trap (FIGURE 2-2).

Section 3 Maintenance

Periodic Maintenance

Instrument Cleaning

The instrument case and meter face must be cleaned periodically with a soft, damp cloth.

⚠ CAUTION

Do not use compressed air to purge the instrument; otherwise, it may contain entrained oil and/or water, which may damage internal components.

Sampling System Checks

The Tankscope sampling system must be checked on a regular basis to verify a proper sample flow rate and that no leaks exist.

NOTE: The Tankscope Model 62T Indicator uses only the thermal conductivity (TC) filament (white base) to detect Butane. The catalytic filament plug (black base) is not used to detect Butane, but must be installed in the filament well to ensure proper gas flow across the TC filament.

Leak Checks

To check for sampling system leaks:

1. Seal the inlet fitting with a finger; squeeze the aspirator bulb.
2. Immediately seal the aspirator bulb outlet with a finger of the other hand.
3. Repeat steps 1 and 2, but do not seal aspirator outlet fitting. This will test the outlet valve for leaks.
 - The system is free of leaks if the bulb remains deflated while the inlet fitting and the bulb outlet are sealed.
 - The system is leaking if:
 - the aspirator bulb inflates

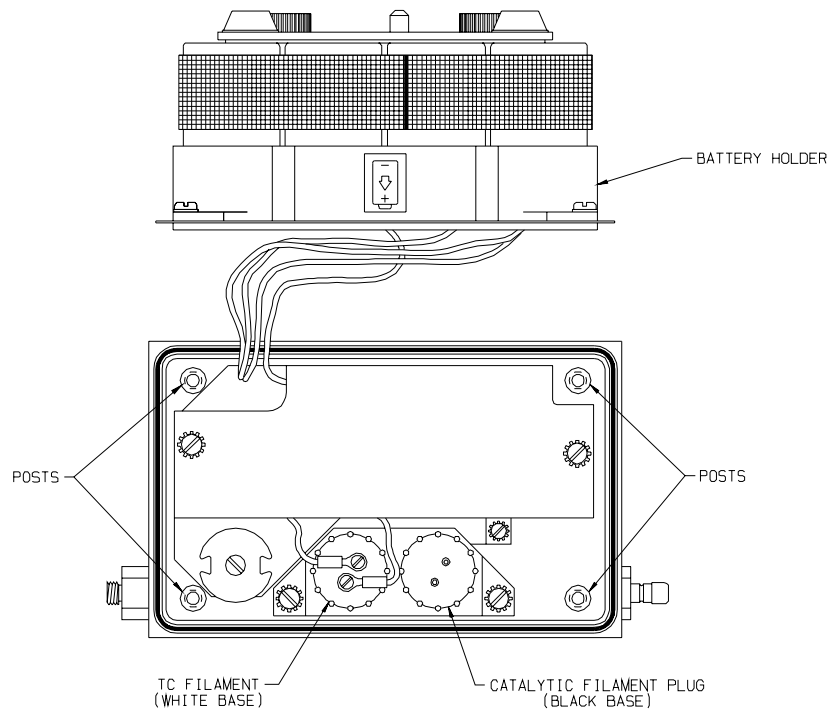

Figure 3-1. TC Filament Location

- a filament seal is leaking
 - the aspirator bulb or valve (outlet) is leaking
 - the instrument inlet or outlet fitting gasket is leaking
 - the tubing is leaking
 - "O" seals under the filament manifold leaking or missing
 - loose mounting screws on filament manifold.
4. If the system is leaking:
- a. Check the filament seals by opening the case and tightening both bases (FIGURE 3-1).
 - b. Repeat steps 1 and 2.

5. If the bulb still inflates, check the gaskets; then, check the aspirator bulb by sealing the inlet fitting with a finger and squeezing the bulb.
 - Replace the bulb if it inflates in less than six seconds.

Flow Rate Checks

A sample should flow through the instrument at 0.03 to 0.05 cubic feet per hour (0.8 to 1.4 LPM). To check for proper flow rate after a leak check:

1. Squeeze the aspirator bulb sealing the aspirator exhaust valve only).
2. Observe that bulb inflates completely in two to four seconds.
3. If it does not, replace the cotton filter:
 - a. Remove the inlet fitting and gasket.
 - b. Using tweezers, remove the filter (FIGURE 3-2).
 - c. Replace filter and reassemble.
4. Disconnect the aspirator bulb tubing from the outlet fitting.
5. Remove the flow regulating orifice (FIGURE 2-1) from the fitting to verify that it is open. Replace if necessary.

NOTE: If it is clogged, insert a #23 gauge (0.0225 in. diameter) wire through the opening. (DO NOT USE A DRILL BIT.)

6. Reassemble completely and reconnect the aspirator bulb.

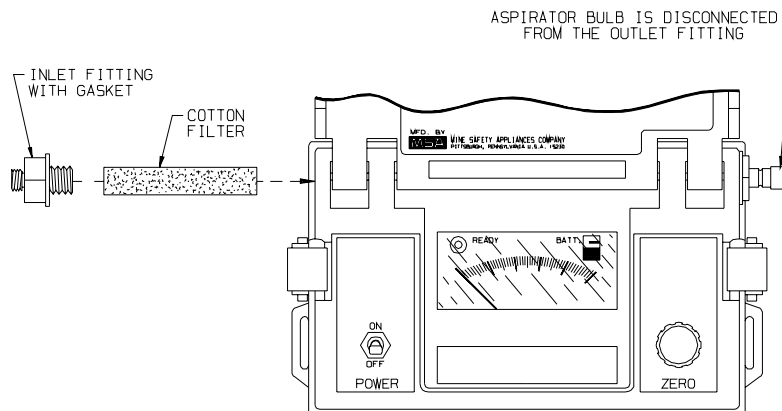

Figure 3-2. Cotton Filter Replacement

7. Repeat steps 1 and 2.
8. If the bulb still does not inflate within four seconds, perform the procedure given under "Flashback Arrester Replacement."
9. If the bulb still does not inflate within four seconds, return the instrument to MSA:

**MSA Instrument Division
Service Department
300 Walden Road
Cranberry Township, PA 16066**

10. If flow is corrected, perform the Chapter 4, "Calibration Procedure."

⚠ WARNING

Do not use the Tankscope 62T Indicator if the flow system has leaks; otherwise, inaccurate readings may occur, which may cause serious personal injury or death.

Troubleshooting

TABLE 3-1 lists the symptoms of the most commonly occurring problems, probable cause(s) and solutions. Refer to this table if the Tankscope 62T Indicator:

- cannot be calibrated by performing the Chapter 4 procedures
- does not operate properly.

Table 3-1. Troubleshooting Guidelines		
NOTE: Perform all troubleshooting in an area free of combustible gases.		
SYMPTOM	PROBABLE CAUSE	CORRECTIVE ACTION
Needle deflects below zero when the ON/OFF switch is set to ON. Meter cannot be zeroed with the ZERO control. READY indicator turns ON.	Loose connection to the white base TC (thermal conductivity) filament	Tighten screws securing the filament wires to the white base (FIGURE 3-1)
	Filament may be open	Perform "TC Filament Replacement" procedure
Needle deflects beyond the upper end of the scale.	TC filament terminals may be short circuited	Remove the short circuit between terminals (FIGURE 3-1)

Table 3-1. Troubleshooting Guidelines		
NOTE: Perform all troubleshooting in an area free of combustible gases.		
SYMPTOM	PROBABLE CAUSE	CORRECTIVE ACTION
Needle deflects away from zero when the ON/OFF switch is set to ON. The READY indicator does not turn ON. BATT status indicator may be near the red zone.	Power supply voltage is too low	Perform "Battery Replacement" procedure
The READY indicator does not turn ON when the ON/OFF switch is set to ON.	Battery contacts are loose	Tighten the nuts on the hex battery posts (FIGURE 3-5)
	Power supply voltage is too low	Perform "Battery Replacement" procedure
	Circuit malfunction	Return instrument to MSA
Aspirator bulb must be squeezed more than the directed number of times to obtain a stable meter indication.	Leak may be present in the sample flow system	Check the sample flow system for leaks by performing "Flow Rate Checks" procedure
	Cotton filter may be clogged	Replace cotton filter
	Flow regulating orifice may be clogged	Open the orifice with #23 gauge wire
	Flashback arresters may be clogged	Perform "Flashback Arrester Replacement" procedure

If the problem cannot be located or corrected by using these guidelines, return the instrument to MSA:

**MSA Instrument Division
Service Department
300 Walden Road
Cranberry Township, PA 16066**

Refer to "Corrective Maintenance" for the following replacement procedures:

- flashback arresters
- filaments
- batteries.

Corrective Maintenance

When an inoperative part is located by following the TABLE 3-1 Troubleshooting Guidelines, replace it according to one of the following procedures:

TC Filament Replacement

(FIGURE 3-1)

To replace the TC filament, perform the following procedure:

1. Lift the cover and loosen the clasps holding the case top and bottom sections together; close cover.
2. Turn the instrument upside down and set it on its cover.
3. Turn the instrument so the inlet and outlet fittings are positioned as shown in FIGURE 3-1.
4. Remove the four screws and lock washers holding the battery holder to the posts; lift off battery holder and place it on its side.
5. Remove the two screws holding the lugs on the orange and white wires connected to the TC filament (white base).
6. Remove the filament with the white base by turning the base counterclockwise until it is free of the well.
NOTE: Be sure to remove only the filament with the white base.
7. Insert the replacement filament (with a white base) into the well.
8. Tighten the filament in the well by turning the base clockwise until the gasket is firmly seated against the block.
9. Verify that the seal around the base does not leak:
 - a. Seal the inlet fitting with a finger.
 - b. Squeeze the aspirator bulb and immediately seal the bulb outlet with a finger of the other hand.
 - If bulb inflates, check the filament gasket and re-tighten the filament.
10. Using the two screws, secure the lugs on the orange and white wires to the white base.
11. Mount the battery holder on the posts and secure it with four screws and lock washers.
12. Perform the Chapter 4, "Calibration Procedure."

Flashback Arrester Replacement

To replace the flashback arrester in the catalytic and thermal conductivity wells, perform the following procedure:

1. Lift cover and loosen the clasps connecting the top and bottom case sections; close the cover.
2. Turn the instrument upside down and set it on its cover.
3. Lift off the bottom case section.
4. Turn the instrument so the inlet and outlet fittings are positioned as shown in FIGURE 3-1.
5. Remove the four screws and lock washers holding the battery holder to the posts; lift off battery holder and place it on its side.
6. Remove the two screws holding the lugs on the orange and white wires to the white base.
7. Remove the TC filament with the white base by turning the base counterclockwise until it is free of the well.
8. Remove the catalytic filament plug with the black base by turning the base counterclockwise until it is free of the well.
9. Loosen the screw holding the absorber (bowl-shaped part) in the TC filament well (FIGURE 3-3); remove absorber and screw.
10. Remove the flashback arresters (FIGURE 3-4) by grasping the pin with long-nose pliers and pulling the arrester out of the sleeve.
11. Insert replacement arresters in the sleeves.

WARNING

The flashback arresters must be installed in the instrument to prevent possible flame from the filament wells. Do not re-use a flashback arrester; otherwise, it will not fit properly in the sleeve and, therefore, cannot prevent flame propagation. Explosion, fire, injury or death could occur if both flashback arresters are not installed properly or if they are reused.

12. Place the absorber and screw in the well; tighten the screw.
13. Loosen the screw holding the deflector plate (disc-shaped) in the catalytic filament well (FIGURE 3-3); remove the deflector and screw.

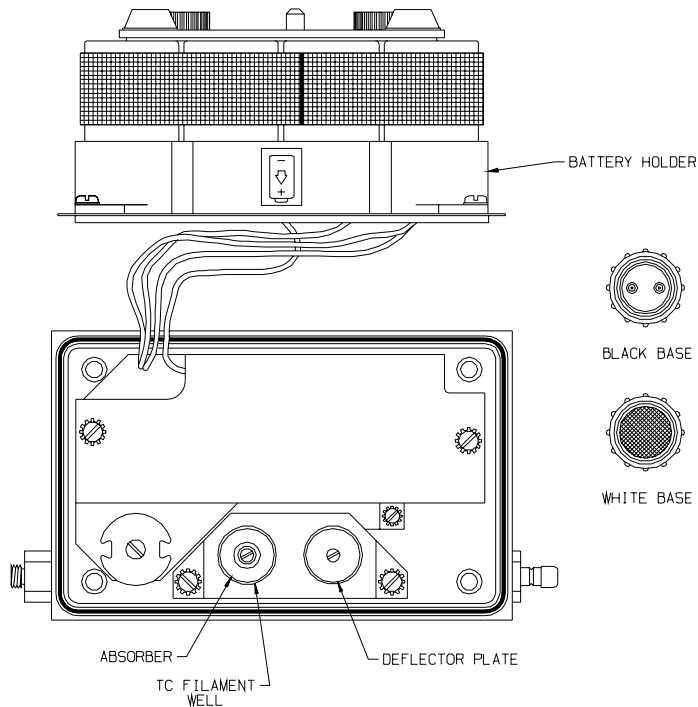

Figure 3-3. Location of Parts in Filament Wells

14. Repeat steps 10 and 11.
15. Align the spacer (FIGURE 3-4) over the center hole and place the deflector in the well.
16. Insert the screw through the hole in the deflector and spacer; secure the deflector by tightening the screws.
17. Insert the catalytic filament plug (with the black base) in the well nearest the outlet fitting; tighten the filament by turning the base clockwise until the gasket is firmly seated against the block.
18. Insert the TC filament (with the white base) in the remaining well; tighten the filament by turning the base clockwise until the gasket is firmly seated against the block.
19. Verify that the seal around both bases does not leak:

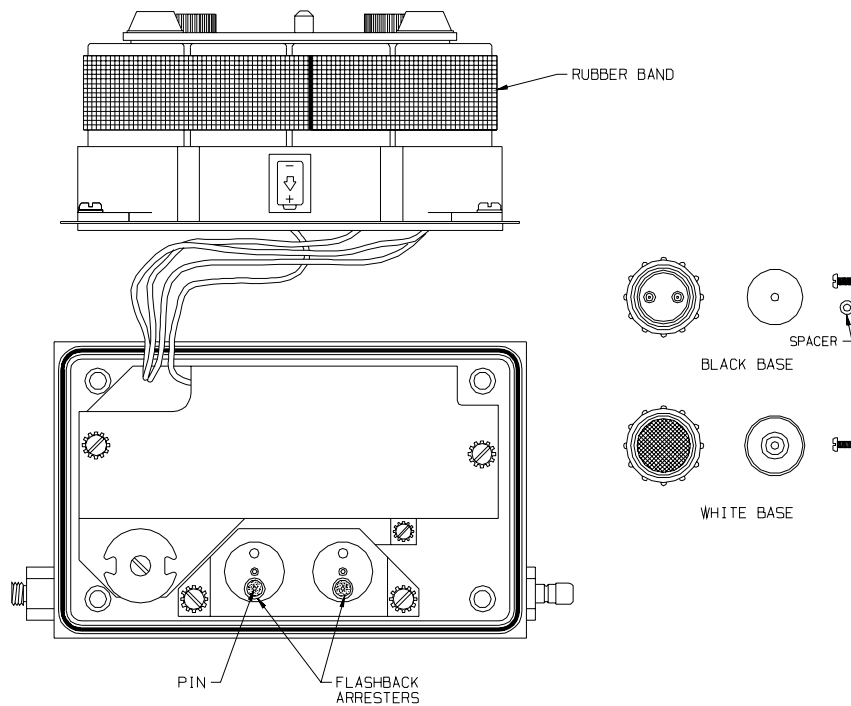

Figure 3-4. Flashback Arrester Locations

- a. Seal the inlet fitting with one finger.
 - b. Squeeze the aspirator bulb and immediately seal the bulb outlet with a finger of the other hand.
 - c. If the bulb inflates, check the filament gaskets and re-tighten the filaments.
 - d. Perform the "Flow Rate Checks" procedure.
20. Using the two screws, secure the white and orange wire lugs to the white base.
 21. Mount the battery holder on the posts and secure it with four screws and lock washers.
 22. Place the bottom section of the case on the instrument so its thumbscrews (FIGURE 3-2) are positioned away from the inlet and outlet fittings.

23. Open the cover and clasp the top and bottom case sections together.
24. Perform the Chapter 4, "Calibration Procedure."

Battery Replacement

1. Lift the cover and loosen the clasps holding the top and bottom case sections together; close the cover.
2. Turn the instrument upside down and set it on its cover.
3. Lift off the bottom case section.
4. Remove the battery retainer (FIGURE 3-4).
5. Remove the two nuts (FIGURE 3-5) and lift off the contact plate.
6. Remove all batteries from the holder and replace them with eight fresh Carbon-Zinc "D" cells (Eveready 950, Burgess 800 or equivalent).
NOTE: Install the batteries with the positive (+) pole down.
7. Replace the contact plate and secure it to the support posts with two nuts.

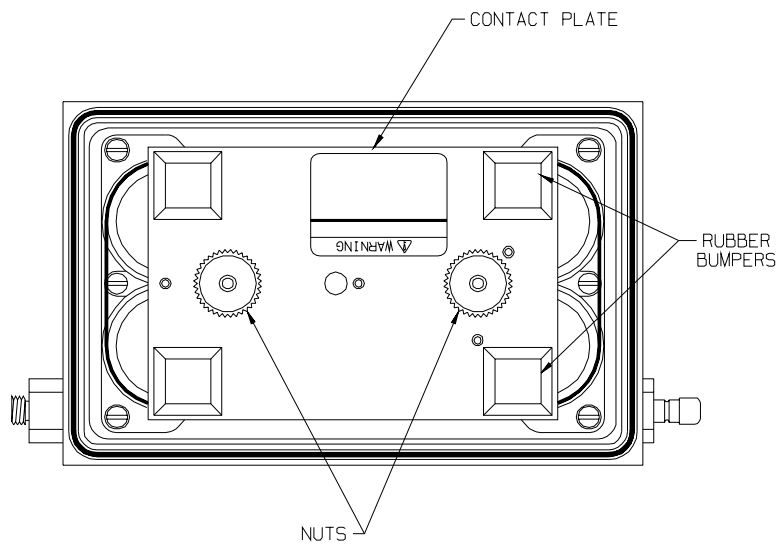

Figure 3-5. Battery Removal

NOTE: Firmly tighten the nuts to ensure good electrical contact between the plate and the negative (-) battery poles.

8. Place the rubber band around the batteries.
9. Place the bottom case section on the instrument so the thumbscrews (FIGURE 3-2) are placed away from the inlet and outlet fittings.
10. Open the cover; clasp the top and bottom case sections together.
11. Perform the Chapter 2, "Operation Check" procedures.

Ordering Parts

To obtain parts, service or information, send the order/inquiry to:

Mine Safety Appliances Company
Portable Instruments Sales Department
P.O. Box 426
Pittsburgh, PA 15230

PART	PART NO.
Battery Retainer	479581
Five-foot sampling line (complete with couplings)	11354
10-foot sampling line (complete with couplings)	11955
15-foot sampling line (complete with couplings)	11912
25-foot sampling line (complete with couplings)	11913
35-foot sampling line (complete with couplings)	11957
50-foot sampling line (complete with couplings)	11958
Four-foot solid probe tube	11960
Three-foot hollow brass probe tube	11961
Four-foot plastic probe tube	73743
Thermal conductivity filament (white base)	74730
Flashback arrester	15264
Detector block assembly (includes flashback arrester P/N 15264)	803761
Batteries, Eight Carbon-Zinc "D" Cells (Eveready 950, Burgess 800 or equivalent)	30052

Table 3-2. Parts List	
PART	PART NO.
Cotton filters, package of six	16499
Line trap (for use with MSA sampling lines)	74814
Line trap (for use with special sampling lines)	468428
Aspirator bulb (complete with check valves)	16839
Calibration Check Kit, Model R	
Flow control (1.5 LPM)	459948
Adapter hose	449482
Calibration check gas cylinder [8% Butane by volume in inert gas (85% Nitrogen, 15% Carbon Dioxide)]	460345
Meter, 0-25% Butane	711259
Main Circuit Board	711261
Power Supply Circuit Board	711260
Cable, 16-pin Ribbon	465468
Potentiometer Assembly	468429
Battery Contact Plate Assembly	465507
"O"-ring Manifold	633918
Tube, Aspirator	073839
Flow Orifice	046314
Panel and Cover Assembly	711484
Instruction Manual	711291

Chapter 4 Calibration

Introduction

- Read this entire chapter before making any Tankscope adjustments.
- This instrument is normally factory-calibrated with 8% Butane, 15% CO₂ in N₂.

Calibration Procedure

- The Tankscope 62T Indicator should be calibrated periodically by performing the following procedure in an atmosphere free of combustible gases.
- Also perform this procedure if the thermal conductivity filament or any other parts are replaced.
- If the instrument cannot be calibrated with this procedure, refer to Chapter 3, "Troubleshooting" or return to MSA for service.
 1. Open the cover and loosen the clasps connecting the top and bottom case sections.
 2. Remove the bottom case section and position the instrument on rubber bumpers so the meter can be seen (FIGURE 4-1).
 3. Set the ON/OFF switch to ON.
 - The meter needle should rest near zero
 - The READY indicator should turn ON; if it does not turn ON, refer to Chapter 3, TABLE 3-1.
 4. Squeeze the aspirator bulb eight to 10 times to purge the instrument with fresh air.

NOTE: Permit the bulb to completely inflate after each squeeze.
 5. Continue squeezing the aspirator bulb as you lift and adjust the 0-5 ZERO control to obtain a zero indication on the meter.
 6. Connect a source of 8% Butane, 15% CO₂ in N₂ to the inlet fitting.
 7. Pass the gas through the instrument.
 - The meter needle should rest on 8.

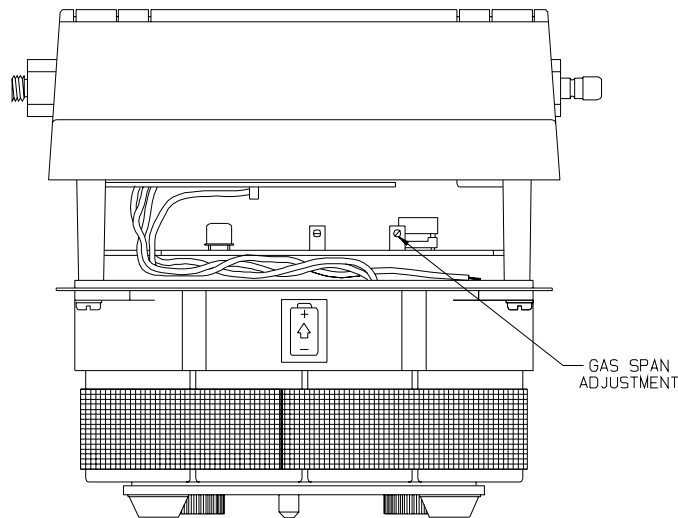

Figure 4-1. Span Adjustment Location

- If it does not read 8, turn the GAS span adjustment to obtain 8 on the meter (FIGURE 4-1).
 - If a meter reading of 8 cannot be obtained by turning the GAS span adjustment, refer to Chapter 3, "TC Filament Replacement" and repeat this procedure.
8. Disconnect the source of Butane, 15% CO₂ in N₂.
 9. Squeeze the aspirator bulb eight to 10 times to purge the instrument with fresh air.
 - The meter needle should indicate zero.
 - If it does not indicate zero, adjust the GAS ZERO control to obtain a zero reading and repeat steps 7 through 9.
 10. Place the instrument into the bottom case section and clasp the top and bottom sections together; close the cover.