

Duo-Flo™

**respirator
constant flow and
pressure demand types**

**instructions
parts lists**

⚠ WARNING

This manual, including the warnings and cautions inside, must be read and followed carefully by all persons who use or maintain this product, including those who have any responsibility involving its selection, application, service or repair. This respirator will perform as designed only if used and maintained according to the instructions. Otherwise, it could fail to perform as designed and persons who rely on this product could sustain serious personal injury or death.

The warranties made by MSA with respect to the product are voided if the product is not used and serviced according to the instructions in this manual. For any additional information relative to use or repair, call 1-800-MSA-2222 during regular working hours.

MSA MINE SAFETY APPLIANCES COMPANY
PITTSBURGH, PENNSYLVANIA, U.S.A. 15230

TAL 7012 (L) Rev. 2

© MSA 2007

Prnt. Spec. 10000005389 (F) Mat. 818369

Doc. 818369

Contents

NIOSH Approval Information	2
Special or Critical User Instructions	2
Instructions	3-10
Respirator Assemblies and Components	11-18

NIOSH APPROVAL INFORMATION

Cautions and Limitations

- A- Not for use in atmospheres containing less than 19.5 percent oxygen.
- B- Not for use in atmospheres immediately dangerous to life or health.
- C- Do not exceed maximum use concentrations established by regulatory standards.
- D- Air-line respirators can be used only when the respirators are supplied respirable air meeting the requirements of CGA G-7.1 Grade D or higher quality.
- E- Use only the pressure ranges and hose lengths specified in the user instructions.
- G- If airflow is cut off, switch to filter and/or cartridge and immediately exit to clean air.
- H- Follow established cartridge and canister change schedules or observe ESLI to ensure that cartridges and canisters are replaced before breakthrough occurs.
- I- Contains electrical parts that may cause an ignition in flammable or explosive atmospheres.
- J- Failure to use and maintain this product properly could result in injury or death.
- L- Follow the manufacturer's User Instructions for changing cartridges and/or filters.
- M- All approved respirators shall be selected, fitted, used, and maintained in accordance with MSHA, OSHA, and other applicable regulations.
- N- Never substitute, modify, add, or omit parts. Use only exact replacement parts in the configuration as specified by the manufacturer.
- O- Refer to User Instructions, and/or maintenance manuals for information on use and maintenance of these respirators.
- S- Special or critical user instructions and/or specific use limitations apply. Refer to User Instructions before donning.

S - Special or Critical User Instructions

▲ WARNING

1. This device does **NOT** supply oxygen. Use only in adequately ventilated areas containing at least 19.5 percent oxygen.
2. This respirator must be used in conjunction with the proper canister or filter for protection against specific contaminants.
3. Do not use when concentrations of contaminants are unknown or immediately dangerous to life or health (IDLH). (See the respirator NIOSH approval matrix to determine if this device can be used for escape from those concentrations.)
4. Do not use when appropriate exposure limit (OSHA, PEL, NIOSH REL, ACGIH TLV, etc.) is not known or when it is below the odor threshold or any other established warning level for the contaminant.

5. Leave area immediately if:
 - a. Breathing becomes difficult;
 - b. Dizziness or other distress occurs;
 - c. You taste or smell contaminant;
 - d. You experience eye, nose or throat irritation.
6. Use strictly in accordance with instructions, labels and limitations pertaining to this device.
7. This respirator may not provide a satisfactory seal with certain facial characteristics, such as beards or large sideburns, that prevent direct contact between the skin and the sealing surface of the facepiece. Do not use this facepiece if such conditions exist.
8. Never alter or modify this device.
9. This respirator is for use by trained and qualified personnel only.
10. Do not use for firefighting.
11. Do not use as an underwater device.
12. Thoroughly check out the apparatus on receipt prior to use.
13. The air delivered to the air supply hose of this device must be respirable and of a purity equal to at least Grade D Gaseous Air of Compressed Gas Association Commodity Specification for Air. G-7.1.
14. Do not use compressed oxygen with this device.
15. Use only the listed hose lengths and air pressure range.

Failure to follow these precautions can result in serious personal injury or death.

APPLICATION and OPERATING PRINCIPLE

The Duo-Flo Respirator is a combination air supplied respirator and air purifying respirator. It is approved by NIOSH for use with either a particulate filter or a chin style gas mask canister for respiratory protection against specific contaminants. See the Approval Matrix for specific protection provided.

The air supplied mode of operation enables the user to work for long periods of time in contaminated atmospheres without depleting the filter or canister. The air purifying mode of operation can be used for entry, egress, and moving from station to station in a contaminated atmosphere. It can also be used for continuous use when an air supply is not available. The Duo-Flo Respirator is not for use in atmospheres containing less than 19.5 percent oxygen. Also, the Duo-Flo Respirator is not for entry into immediately dangerous to life or health (IDLH) atmospheres.

Constant Flow Type (Advantage® 4000, Ultravue®, and Ultra Elite® Facepieces) — During use, the air supplied mode of operation prevails as long as the user is connected to an air source. The air purifying mode of operation is entered automatically if the air-line is disconnected or if the air source is lost for any reason.

Pressure Demand Type (Ultravue and Ultra Elite Facepieces) — During use, the D/PD exhalation valve must be in the FILTER/CANISTER position when using the respirator in the air purifying mode of operation. When the air-line is connected, the

user must switch the D/PD exhalation valve to the AIR-LINE position to use the respirator in the air supplied mode of operation. When the air-line is disconnected or if the air source is lost for any reason, the user must switch the D/PD exhalation valve back to the FILTER/CANISTER position to again use the respirator in the air purifying mode of operation.

Inhaled air enters the respirator either through the filter or canister or from the air-line. The inhaled air passes over the facepiece lens, keeping it free from fog, before it is taken into the lungs. Exhaled air leaves the facepiece through the exhalation valve and consequently is not rebreathed. A check valve prevents the exhaled air from passing out through the filter or canister.

Note: Training on the Pressure Demand Duo-Flo Respirator should include a brief familiarization period where the employee is allowed to use the device in both modes. This will allow the employee to recognize the higher breathing resistance associated with the air-line position of the D/PD exhalation valve and allow him/her to practice switching the valve from one position to the other.

Respirator Use Limitations

The wearer must comply with the following MSA respirator use limitations:

1. Maximum Use Concentration

Do not exceed ANY of the applicable maximum use concentrations listed below:

RESPIRATOR USE \ RESPIRATOR TYPE	RESPIRATORS WITH ULTRA FILTER® OR OPTIFILTER® XL FILTER CARTRIDGES		RESPIRATORS WITH CANISTERS
	FULL FACEPIECE	HALF MASK	FULL FACEPIECE ONLY
Routine Use in Air-Supplied Mode Only - including entry, continuous use and non-emergency egress	<ul style="list-style-type: none"> • 1,000 times Exposure Limit • IDLH 	<ul style="list-style-type: none"> • 10 times Exposure Limit • IDLH 	<ul style="list-style-type: none"> • 1,000 times Exposure Limit (combined for all contaminants present) • IDLH (for any contaminant present) • <u>Gas/Vapor Contaminants</u> • Canister Escape Limit • <u>Particulate Contaminants</u> • High Efficiency Filter: 1000 times Exposure Limit • Non-High Efficiency Filter: 100 times Exposure Limit
Routine use in air-purifying mode - including entry, continuous use, non-emergency egress and/or moving from station-to-station	<ul style="list-style-type: none"> • 100 times Exposure Limit • IDLH 	<ul style="list-style-type: none"> • 10 times Exposure Limit • IDLH 	<ul style="list-style-type: none"> • 100 times Exposure Limit • IDLH • Canister Escape Limit
Emergency Escape in Air-Purifying Mode	<ul style="list-style-type: none"> • Unlimited 	<ul style="list-style-type: none"> • Unlimited 	<ul style="list-style-type: none"> • <u>Gas/Vapor Contaminants</u> • Canister Escape Limit • <u>Particulate Contaminants</u> • Unlimited

2. The limitations outlined in the applicable NIOSH approval.
3. Any applicable limitation contained in a standard established by a regulatory agency (such as OSHA) with jurisdiction over the wearer.
4. Do not wear for protection against substances with poor warning properties or those which generate high rates of reaction with sorbent material in the canister.
5. Mixtures of Contaminants — NIOSH allows this respirator to be used for protection against a mixture of contaminants that are present simultaneously or alternately against one contaminant then another (using the same canister) if the mixture meets the following conditions:
 - a. The canister must be approved for all contaminants present.
 - b. NIOSH permits mixing of the following contaminants: organic vapors, acid gases, ammonia, chlorine dioxide, hydrogen sulfide, and carbon monoxide.
 - c. Particulates can be mixed with any other particulate or any gas or vapor for which the canister is approved.
 - d. Contaminants present simultaneously must be below IDLH levels for the specific contaminants. If any one contaminant in the mixture exceeds the IDLH concentration then the entire mixture must be treated as IDLH and the respirator cannot be used (except for escape).

Time Use Limitation

Canisters with an N95 filter shall be limited to 8 hours of use (continuous or intermittent) against particulates. [Service time can be extended by performing an evaluation in the specific workplace setting that demonstrates (a) that the extended use will not degrade the filter efficiency below 95% or (b) that the total mass loading of the filter is less than 200 mg.]

EXPOSURE LIMITS

A listing of acceptable exposure limits from the following sources is provided in MSA's *Response® Respirator Selector* (available online at www.msanet.com):

- American Conference of Governmental Industrial Hygienists (ACGIH)
- Occupational Safety and Health Administration (OSHA)
- National Institute for Occupational Safety and Health (NIOSH)
- American Industrial Hygiene Association (AIHA)

Contact MSA at 1-800-MSA-2222 for information.

Exposure Limits for Mixtures

The American Conference of Governmental Industrial Hygienists (ACGIH) publishes the following information to determine the TLV of a mixture.

First, determine the total concentration of the chemical mixture (C_{Mixture}) from the individual contaminant concentrations (C_1, C_2, C_3, \dots) using the following formula:

$$C_{\text{Mixture}} = C_1 + C_2 + C_3 + \dots$$

The TLV of the mixture is found by using the following formula where T_1, T_2, T_3, \dots are the individual contaminant TLVs and C_1, C_2, C_3, \dots are the individual contaminant concentrations:

$$T_{\text{Mixture}} = \frac{C_{\text{Mixture}}}{\frac{C_1}{T_1} + \frac{C_2}{T_2} + \frac{C_3}{T_3} + \dots}$$

Only use these equations if the contaminants present are actually mixed. Some substances do not mix and may be present separately, for example, in pockets or at different levels. In that case, the lowest TLV of the substances present must be used to determine the appropriate respirator category for protection against all contaminants present.

See MSA's Response Respirator Selector (available online at www.msanet.com) for additional information.

RESPIRATOR FIT TEST

A qualitative or quantitative respirator fit test must be carried out for each wearer of this respirator to determine the amount of protection it will provide. Respirator fit tests are explained fully in the American National Standard for Respiratory Protection, ANSI Z88.2, which is published by the American National Standards Institute, 11 West 42nd Street, New York, New York 10036.

Quantitative Test

If a quantitative fit test is used, a fit factor that is at least 1,000 for a full facepiece respirator and 100 for a half-mask respirator shall be obtained before that respirator is assigned to an individual.

Qualitative Test

If a qualitative fit test is used, only validated protocols are acceptable. The individual must pass a test designed to assess a fit factor of at least 1,000 for a full facepiece respirator and 100 for a half-mask respirator.

Duo-Flo Respirators must be qualitatively or quantitatively fit tested in a negative-pressure mode. This will cover use of the respirator in both air-purifying and air-supplied modes of operation.

⚠ WARNING

The user must perform a respirator fit test and follow all warnings and limitations specified. Failure to do so can result in serious personal injury or death.

BEFORE USE

1. Make sure certain conditions of exposure are (a) within the limits for which the device is approved (see appropriate NIOSH approval plate) or, (b) within the limits established by MSA for the particular cartridge (see cartridge label).

Do not use in areas which are not ventilated. Do not use in atmospheres containing less than 19.5 percent oxygen or in atmospheres immediately dangerous to life or health. If oxygen concentration sufficient to support life is questionable, use self-contained breathing apparatus only.

⚠ WARNING

DO NOT wear for protection against organic vapors with poor warning properties or those which generate high heats or reaction with sorbent materials in the canister. Failure to follow this warning can result in serious personal injury or death.

⚠ WARNING

DO NOT use the Advantage 4000 Facepiece w/chin canisters P/Ns 815993, 815995, 815996, 815998, 815999, and 816051. Failure to follow this warning can result in serious personal injury or death.

2. Wear impermeable protective clothing for exposure to gases and vapors which can poison by skin absorption.
3. Assure that a source of air is available which conforms to the requirements as specified in the “air-supply” section.
4. Assemble apparatus as follows:
 - a. Connect filter cartridge or canister to coupling nut on Duo-Flo adapter check valve.
 - b. Attach breathing tube between Duo-Flo adapter tee and facepiece.
5. Don and adjust in fresh air only as described in the “Fitting the mask” section. Check facepiece tightness as outlined in the “Test for Tightness” section.
6. If a canister is being used, remove the seal from the bottom before entering a contaminated atmosphere. See Replacing Filter/Canister section for replacement information.
7. If a filter is being reused, see Replacing Filter/Canister section.

DURING USE

When using Duo-Flo Respirator with air-line disconnected, the dust cover must be placed onto the air-line quick disconnect fitting (Foster steel or SnapTite fittings only).

Return to fresh air immediately if leakage is detected by smell, taste, or eye, nose or throat irritation, or any feeling of nausea, dizziness or ill being develops.

AFTER USE

1. Replace seals on canister, if reusable.
2. Check condition of apparatus. Clean and replace any necessary parts.
3. Store apparatus in clean, dry location.

FITTING THE MASK

Full Facepiece (All types)

Pull out headband straps, especially the “FRONT” or forehead strap, so that its end is at the buckle, then grip facepiece between thumb and fingers, insert chin well into the lower part of facepiece and pull headbands back over head. To obtain a firm and comfortable fit against the face at all points, adjust the headbands as follows:

1. See that straps lie flat against head.
2. Tighten lower or “Neck” straps.
3. Tighten the “SIDE” straps. (Do not touch forehead or “FRONT” strap).
4. Place both hands on headband pad and push it towards the neck.
5. Repeat operations 2 and 3.
6. Tighten forehead or “FRONT” strap a few notches if necessary.

Half-Facepiece (Comfo only)

Fit facepiece on nose bridge making sure that you are able to breathe through nose. Then swing bottom of facepiece into contact with the chin.

When using elastic or rubber headbands, position headbands with longest straps above the ears and over the crown of the head, and headbands with shortest straps below the ears and around nape of the neck. When using cradle headband, position cradle headband around the crown of the head, and bottom headbands below the ears and around the nape of the neck.

Then, adjust the straps for a comfortable fit by moving adjustment slides to lengthen or shorten straps. Adjust the straps just snug enough so that no air leaks around the facepiece. It is not necessary to pull the straps so tight that the the respirator digs into the face.

TEST FOR TIGHTNESS

The facepiece must be subjected to the following tightness test before each use. With air-line disconnected, test the apparatus facepiece for tightness by holding the hands tightly over the inlet(s) of the filter or canister. Inhale gently so that the facepiece collapses slightly and hold the breath for ten seconds. The facepiece will remain collapsed while the breath is held providing the assembly is gas tight. If any leakage is detected around the facial seal, readjust head harness straps and repeat test until there is no leakage. If other than facial seal leakage is detected, the condition must be investigated and corrected before another test is made. The facepiece must pass the tightness test before the user should attempt to enter any toxic atmosphere.

REPLACING FILTER/CANISTER (Air-Purifying Configurations)

The length of time the P100 filter or canister will give protection depends on the concentration of the contaminant and the rate of breathing while in the air-purifying mode of operation. The N95 filter is effective for 8 hours of use (continuous or intermittent). [Service time can be extended by performing an evaluation in the specific

workplace setting that demonstrates (a) that the extended use will not degrade the filter efficiency below 95%, or (b) that the total mass loading of the filter is less than 200mg.] Follow established filter and canister change schedules or observe ESLI to insure the filters and canisters are replaced before breakthrough occurs. User instructions should also reflect this change.

Remove the exhausted filter or canister and examine the gasket in the coupling nut making sure it is properly in place before attaching a suitable new canister.

▲ WARNING

Protection voided if sealing gaskets are not in their proper place. Failure to follow this warning can result in serious personal injury or death.

▲ CAUTION

The bottom seal on the canister should be replaced after each use.

S-Special or Critical Users Instructions

AIR-SUPPLY HOSE

1. Air Supply Hose - Any combination of the following air supply hoses which does not exceed 300 feet may be used:
 - Part No. 455020 - Hose, Neoprene, 15 ft., Brass, Model No. 7-665-1
 - Part No. 455021 - Hose, Neoprene, 25 ft., Brass, Model No. 7-665-1
 - Part No. 455022 - Hose, Neoprene, 50 ft., Brass, Model No. 7-665-1
 - Part No. 471511 - Hose, PVC, 15 ft., Brass, Model No. 7-664-1
 - Part No. 471512 - Hose, PVC, 25 ft., Brass, Model No. 7-664-1
 - Part No. 471513 - Hose, PVC, 50 ft., Brass, Model No. 7-664-1
 - Part No. 474043 - Hose, Coiled Nylon, 50 ft., Model No. 5-511-1
 - Part No. 481051 - Hose PVC, 8 ft., Brass
 - Part No. 481071 - Hose, Neoprene, 8 ft.

See Air Hose Connection Instruction Sheet P/N 995602 for possible assemblies which may be used to connect air supply hoses and valves.

The maximum number of hose sections that may be used in making up the maximum length of hose is as follows:

When connecting hoses using Locking Quick-Disconnects, only one section of 8 ft. or 15ft. hose may be used.

- 3/8" Low Pressure (10 psig - 15 psig) Constant Flow Assembly may use a maximum of 2 sections of 3/8" air supply hose in making up the maximum length of hose.
- 3/8" High Pressure (35 psig - 40 psig) Constant Flow Assembly may use a maximum of 12 sections of 3/8" non-coiled air supply hose in making up the maximum length of hose. A maximum of 6 sections of coiled hose may be used.

2. Pressure -
 - a. Constant Flow - Air must be supplied to the inlet end of the air hose under a pressure between 35-40 psig.
 - b. Pressure Demand (Ultravue and Ultra Elite Facepieces only) - Air must be supplied to the inlet end of the air hose under a pressure between 65-85 psig.
3. Air Source - The purity of the air supply is the responsibility of the user. The respirator is approved only when the air supplied meets the requirements of Compressed Gas Association Specification G-7.1 for type I, Class D Gaseous Air. This requires that the air contain no more than 20 parts per million (ppm) carbon monoxide, not more than 1000 parts per million (ppm) carbon dioxide, and not more than 5 milligrams per cubic meter of oil vapor or oil particulates.

CLEANING AND DISINFECTING

The facepiece (with the canister removed) should be cleaned and disinfected after every use with MSA's Confidence Plus® Cleaning Solution (P/N 10009971).

1. Make a solution following the instructions.
2. Immerse soiled equipment in the solution and clean gently with a soft brush until clean. Take care to clean the exhalation valve in the facepiece and all other parts that exhaled air contacts.
3. Rinse in plain warm water (maximum 110°F.) and then dry. None of the metal, plastic, rubber, leather, cloth, or glass parts will be adversely affected by the cleaning solution.

⚠ CAUTION

Cleaning and Disinfecting at or below 110°F will avoid possible overheating and distortion of parts of the respirator assembly, which would require replacement.

Instructions for Disassembling and Cleaning the D/PD Valve

1. Remove D/PD valve (Ultravue Facepiece only) by carefully pulling valve from rubber of facepiece.
2. Remove the three screws from around the outside of the valve. Do not attempt to remove the screw in the bottom of the valve. Remove plunger assembly and spring from the body assembly.
3. To clean, follow instructions above.
4. If any parts of the D/PD valve are cracked, torn, or in any way damaged, the valve must be replaced.
5. For reassembly:
 - a. Insert spring back into body assembly. Push plunger assembly into the body assembly and line up the grooves with the holes. Thread the three screws securely into the assemblies. Turn the D/PD valve between the in and out positions to see if the valve is functioning.
 - b. Install D/PD valve into the facepiece so that the groove on the valve is inserted into the exhalation valve hole under the chin cup of the facepiece. Make sure that the large portion of the valve is on the outside. Align the inside oval of the valve so that it does not interfere with the inlet assembly or chin cup.

MAINTENANCE

This apparatus must be kept in good condition to function properly. When any part shows evidence of excessive wear or damage, it must be replaced immediately with the proper part. Extra parts should be readily available.

This apparatus should be stored in a clean dry location when not in use.

⚠ WARNING

DO NOT enter any atmosphere with this respirator unless you know that:

- 1. You have read, understood and followed all instructions and warnings pertaining to the respirator.**
- 2. The respirator and conditions meet the requirements outlined.**
- 3. The canister is the proper type for the contaminant or contaminants present.**
- 4. The amount of oxygen is sufficient to support life (at least 19.5 percent oxygen by volume at sea level). Do not use if oxygen concentration sufficient to support life is questionable.**
- 5. Respirator does not leak (see Test for Tightness).**
- 6. Canister does not need replacing. Discard exhausted canister.**

Failure to follow this warning can result in serious personal injury or death.

Duo-Flo Constant Flow Respirator Assemblies

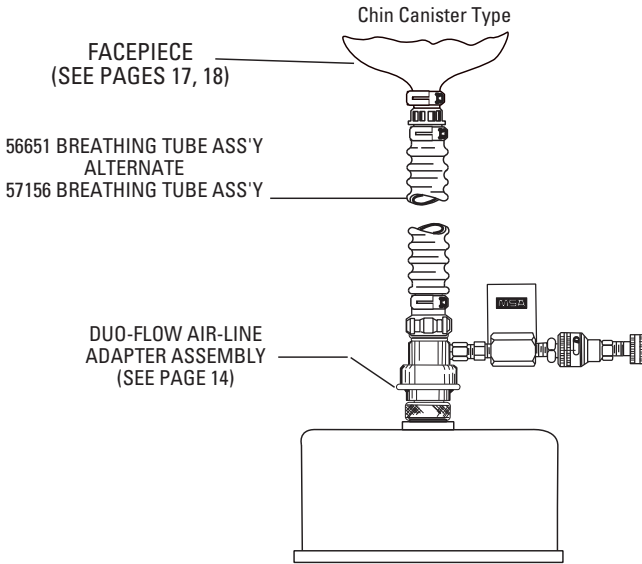

**Duo-Flow Constant Flow
Air-line Adapter
Assemblies Complete
Model 5-260
Part No.**

466077
476919
476920
466058
476918
476922
476921
476923
479114
479115

**Duo-Flow Constant Flow
Air-line Adapter
Assemblies Less
Quick Disconnect Socket
Part No.**

480022
480025
480026
480021
480024
480028
480027
480029
480030
480031

Type

Snap-Tite (AL)
Snap-Tite (Brass)
Snap-Tite (SST)
Foster (Steel)
Foster (Brass)
Hansen (Brass)
Hansen (SST)
Duff-Norton
Cejn, Locking
Snap-Tite (AL),
Locking

Duo-Flo Constant Flow Respirator Components

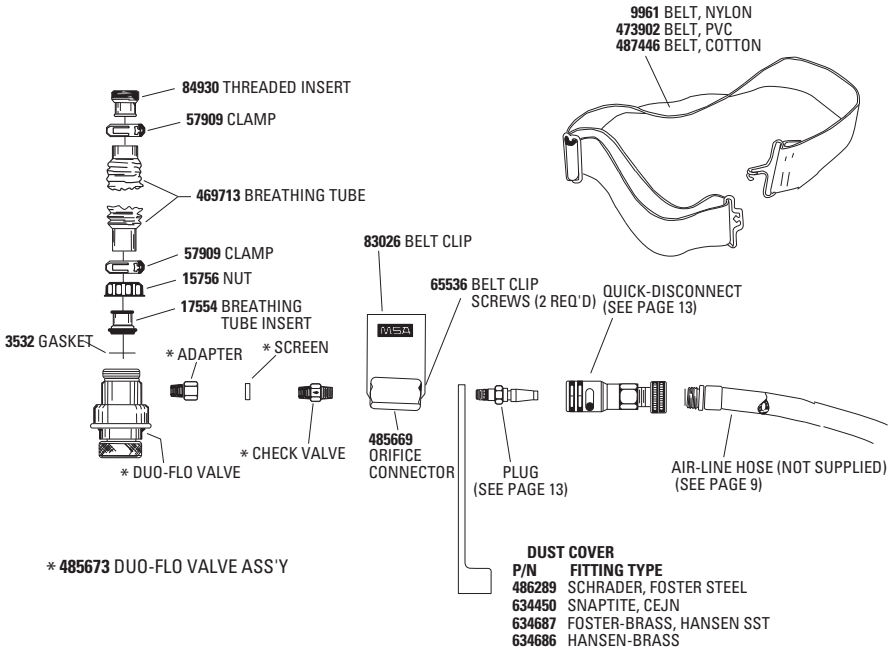

Duo-Flo Constant Flow Quick Disconnects for Flow Control Devices

CEJN — Chrome (C)

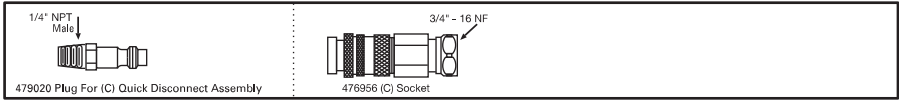

SNAP-TITE — Aluminum (AL)

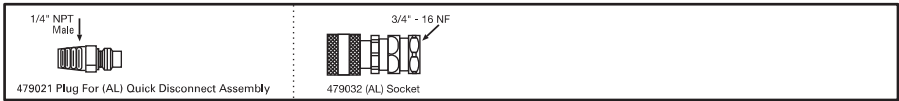

NON-LOCKING TYPES

SNAP-TITE — Aluminum (AL) Brass (BR) Stainless Steel (SST)

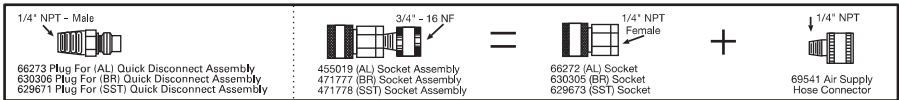

FOSTER — Steel (S)

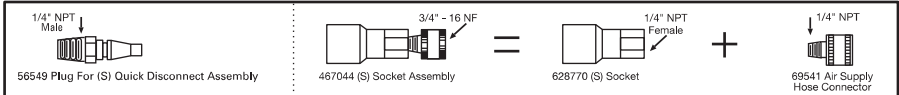

HANSEN — Brass (BR)

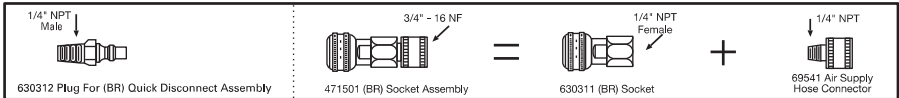

DUFF-NORTON — Brass (BR)

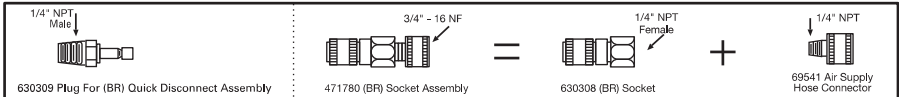

NON-LOCKING TYPES — WITH CHECK VALVE IN PLUG

FOSTER — Brass (BR)

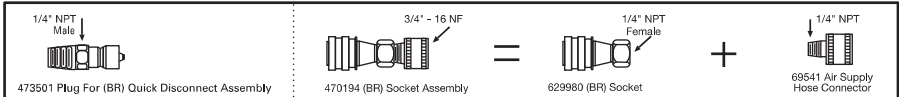

HANSEN — Stainless Steel (SST)

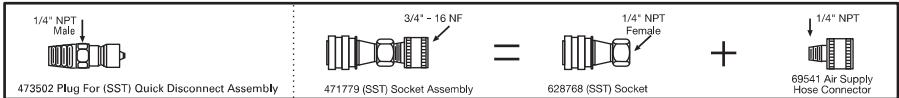

Duo-Flo Constant Flow Respirator Assemblies

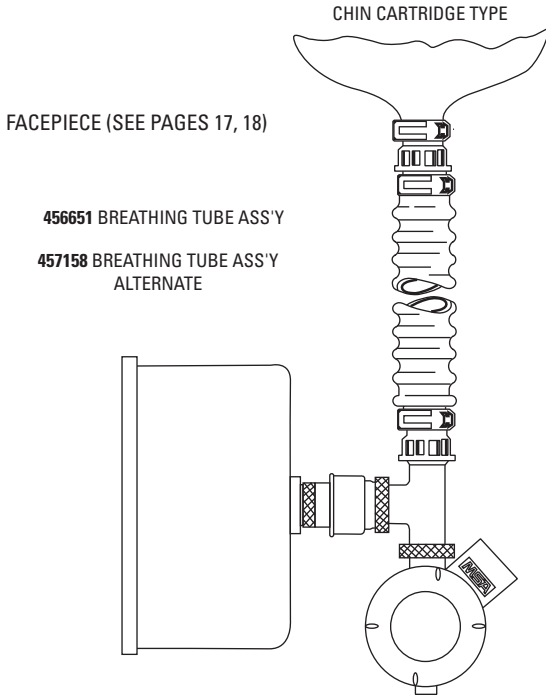

479118

480034

Hansen (SST),
Locking

**Duo-Flow Regulator
Assemblies Complete
Model 7-679-1
Part No.**

**Duo-Flow Regulator
Assemblies Less
Quick Disconnect Socket
Part No.**

Type

481934
481937
481938
481935
481936
481940
481939
481941
481943

481871
481873
481874
481870
481872
481876
481875
481877
481878

Snap-Tite (AL)
Snap-Tite (Brass)
Snap-Tite (SST)
Foster (Steel)
Foster (Brass)
Hansen (Brass)
Hansen (SST)
Duff-Norton
Cejin, Locking

Duo-Flo Pressure Demand Respirator Components

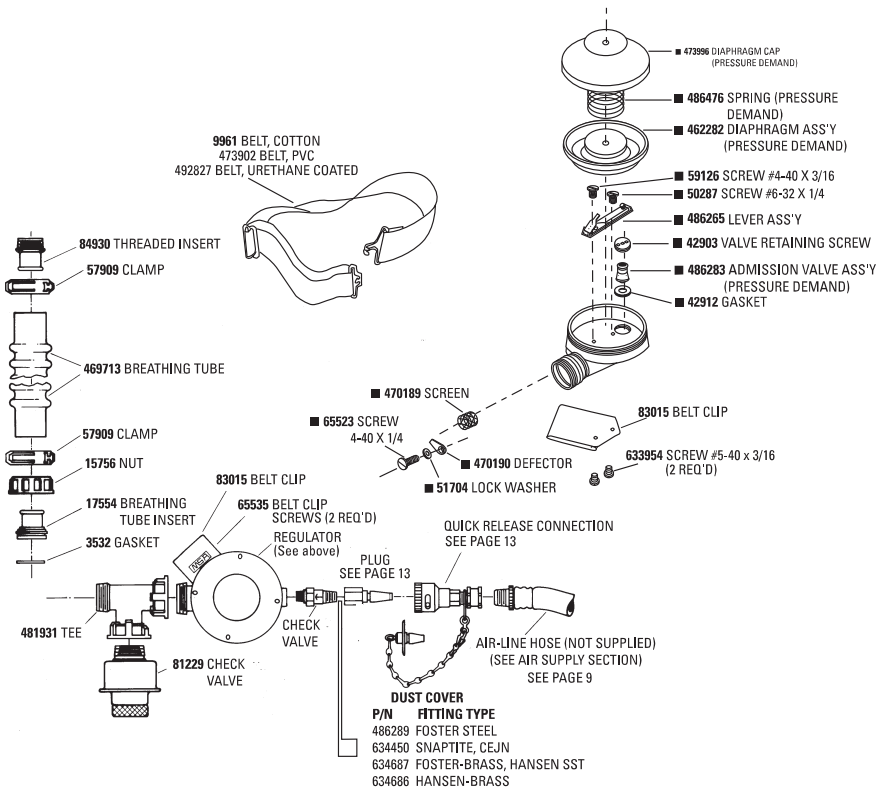

Duo-Flo Pressure Demand Quick Disconnects for Flow Control Devices

LOCKING TYPES

CEJN — Chrome (C)

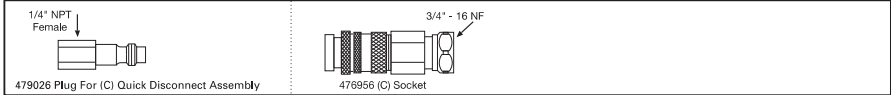

SNAP-TITE — Aluminum (AL)

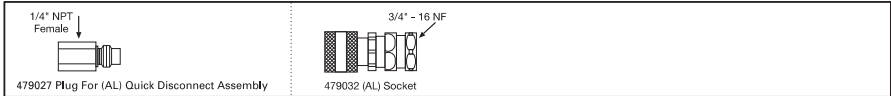

NON-LOCKING TYPES

SNAP-TITE — Aluminum (AL) Brass (BR)

Stainless Steel (SST)

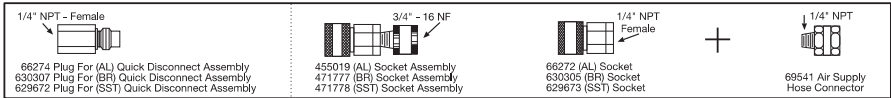

FOSTER — Steel (S) Stainless Steel (SST)

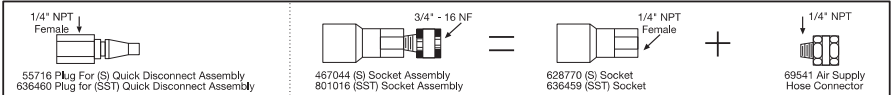

HANSEN — Brass (BR)

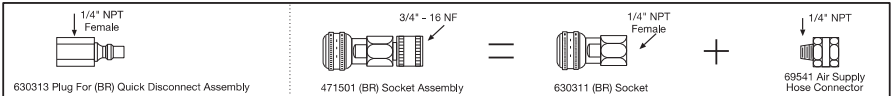

DUFF-NORTON — Brass (BR)

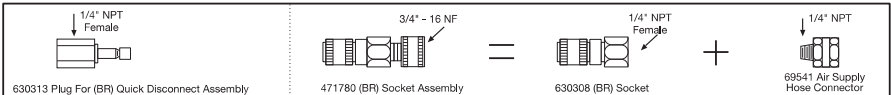

NON-LOCKING TYPES — WITH CHECK VALVE IN PLUG

FOSTER — Brass (BR)

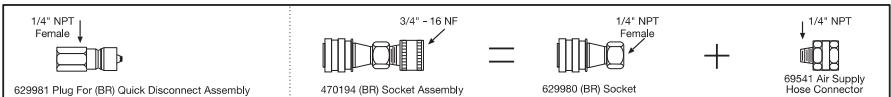

HANSEN — Stainless Steel (SST)

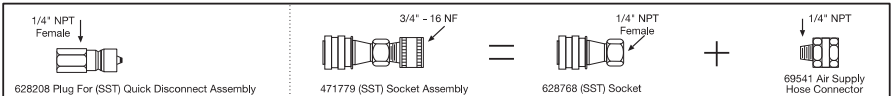

Ultravue® Demand Facepiece Facepiece Assemblies

SMALL — MODEL 7-203-2								MEDIUM — MODEL 7-203-1								LARGE — MODEL 7-203-3							
PART NUMBER	RUBBER		SPEAKING DIAPHRAGM				NOSECUP	PART NUMBER	RUBBER		SPEAKING DIAPHRAGM				NOSECUP	PART NUMBER	RUBBER		SPEAKING DIAPHRAGM				NOSECUP
	Black Hycar	Black Silicone	Green Hycar	With	Less	With			Less	Black Hycar	Black Silicone	Green Hycar	With	Less			With	Less	Black Hycar	Black Silicone	Green Hycar	With	
471218	•				•		•						•									•	
471219	•												•									•	
471220	•												•									•	
471221	•												•									•	
471222			•		•								•									•	
471223			•		•								•									•	
471224			•		•								•									•	
471225			•		•								•									•	
480251		•			•								•									•	
480252		•			•								•									•	
480253		•			•								•									•	
480254		•			•								•									•	
457126													•									•	
471209													•									•	
471212													•									•	
471213													•									•	
463872													•									•	
471211													•									•	
471214													•									•	
471215													•									•	
480247													•									•	
480248													•									•	
480249													•									•	
480250													•									•	
471230													•									•	
471231													•									•	
471232													•									•	
471233													•									•	
471234													•									•	
471235													•									•	
471236													•									•	
471237													•									•	
480255													•									•	
480256													•									•	
480257													•									•	
480258													•									•	

Facepiece Components

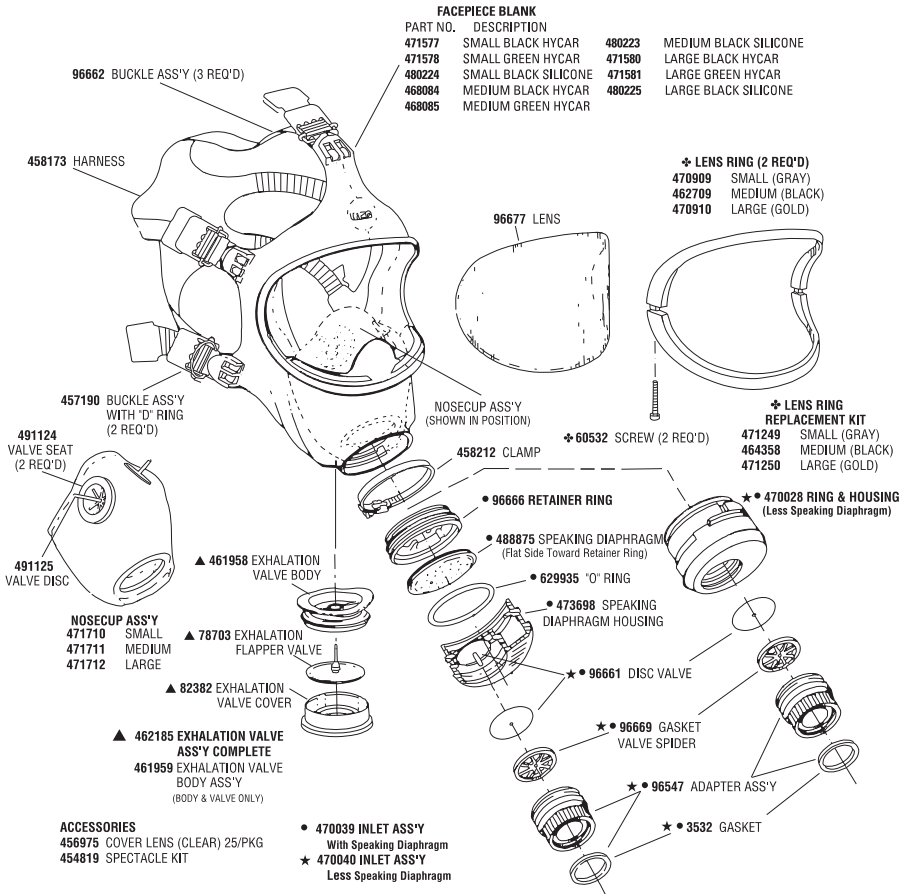

Ultravue® D/PD Facepiece

Facepiece Assemblies

SMALL — MODEL 7-753-2								MEDIUM — MODEL 7-753-1								LARGE — MODEL 7-753-3										
PART NUMBER	RUBBER			SPEAKING DIAPHRAGM		NOSECUP			PART NUMBER	RUBBER			SPEAKING DIAPHRAGM		NOSECUP			PART NUMBER	RUBBER			SPEAKING DIAPHRAGM		NOSECUP		
	Black Hycar	Black Silicone	Green Hycar	With	Less	With	Less	Black Hycar		Black Silicone	Green Hycar	With	Less	With	Less	Black Hycar	Black Silicone		Green Hycar	With	Less	With	Less			
484579	•			•		•		484562	•			•		•		484596	•			•		•				
484560	•					•		484563	•					•		484597	•					•				
484581	•					•		484564	•					•		484598	•					•				
484582	•					•		484565	•					•		484599	•					•				
484583				•		•		484566				•		•		484600				•		•				
484584				•		•		484567				•		•		484601				•		•				
484585				•		•		484568				•		•		484602				•		•				
484586				•		•		484569				•		•		484603				•		•				
484592		•				•		484575				•		•		484609				•		•				
484593		•				•		484576				•		•		484610				•		•				
484594		•				•		484577				•		•		484611				•		•				
484595		•				•		484578				•		•		484612				•		•				

Facepiece Components

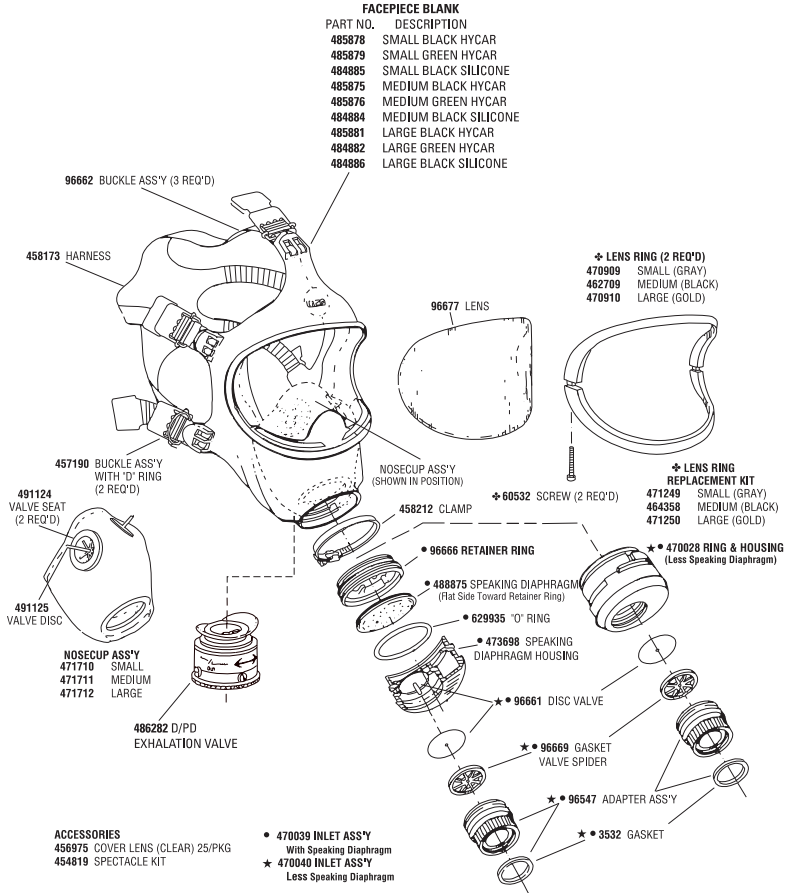

ADVANTAGE[®] 4000

ADVANTAGE 4000 ASSEMBLY	
PART NUMBER	DESCRIPTION
10083792	FACEPIECE ASSEMBLY SINGLE SILICONE MEDIUM
10083793	FACEPIECE ASSEMBLY SINGLE HYCAR MEDIUM
10083796	FACEPIECE ASSEMBLY SINGLE SILICONE SMALL
10083797	FACEPIECE ASSEMBLY SINGLE HYCAR SMALL
10083800	FACEPIECE ASSEMBLY SINGLE SILICONE LARGE
10083801	FACEPIECE ASSEMBLY SINGLE HYCAR LARGE

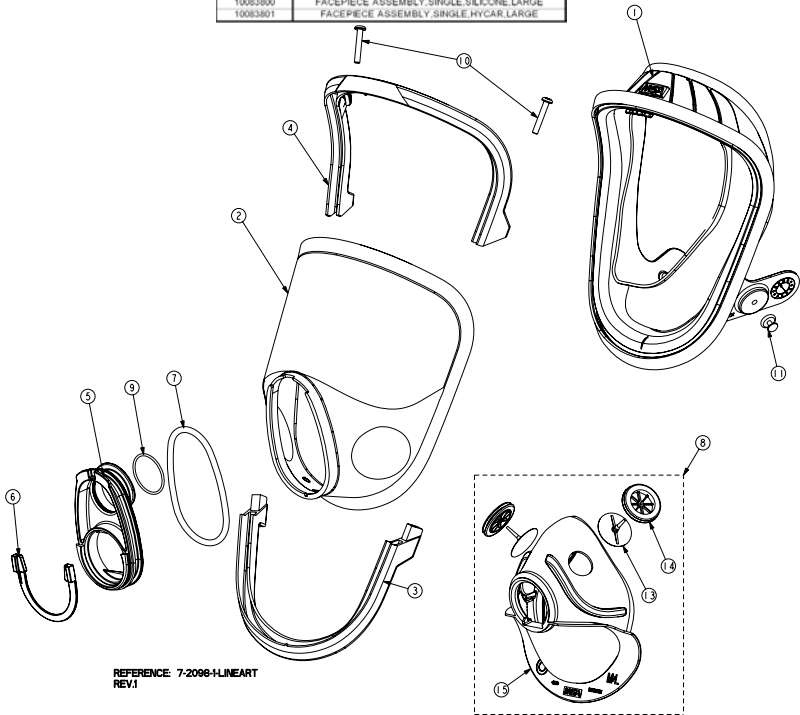

REFERENCE: 7-2098-1 LINEART
REV1

ADVANTAGE 4000 SINGLE PORT FACEPIECE COMPONENTS				ADVANTAGE 4000 SINGLE PORT FACEPIECE COMPONENTS (CONT.)			
ITEM NO.	PART NUMBER	QTY REQD	DESCRIPTION	ITEM NO.	PART NUMBER	QTY REQ	DESCRIPTION
1	10073455	1	FACEBLANK, HYCAR, SMALL	10	10026562	2	SCREW, SST.4M X 25MM LG. PHIL PAN HD
	10073457		FACEBLANK, HYCAR, LARGE	11	10025288	2	BUTTON, HEAD HARNESS
	10073459		FACEBLANK, HYCAR, MEDIUM	465008	1	BAG, DRAWSTRING	
	10083926		FACEBLANK, SILICONE, SMALL	10029294	1	COVER, LENS	
	10083927		FACEBLANK, SILICONE, LARGE	10075903	1	CLOTH HEAD HARNESS ASSEMBLY	
	10083925		FACEBLANK, SILICONE, MEDIUM	10075901	1	RUBBER HEAD HARNESS	
2	10074738	1	LENS, SINGLE PORT 4100-H	NOSECUP ASSEMBLY COMPONENTS (ITEM 8)			
	10084808		LENS, SINGLE PORT 4100-S	13	304787	2	DISC, VALVE
3	10073461	1	LENS RING, LOWER, BLACK	14	491124	2	SEAT, VALVE
4	10073460	1	LENS RING, UPPER, BLACK	15	10065305	1	NOSE CUP, MEDIUM/LARGE, TPE
5	10061973	1	HOUSING, INLET	10065306	1	NOSE CUP, SMALL, TPE	
6	10061966	1	UCLIP				
7	10025297	1	O-RING, HOUSING, SILICONE				
8	10065803	1	NOSECUP ASSEMBLY, MED/LG				
	10065804		NOSECUP ASSEMBLY, SMALL				
9	10084819	1	O-RING, SIZE, 2-024				

ADVANTAGE[®] 4000

ADVANTAGE 4000 ASSEMBLY	
PART NUMBER	DESCRIPTION
10065330	ADVANTAGE 4000 INLET ASSEMBLY,RD40

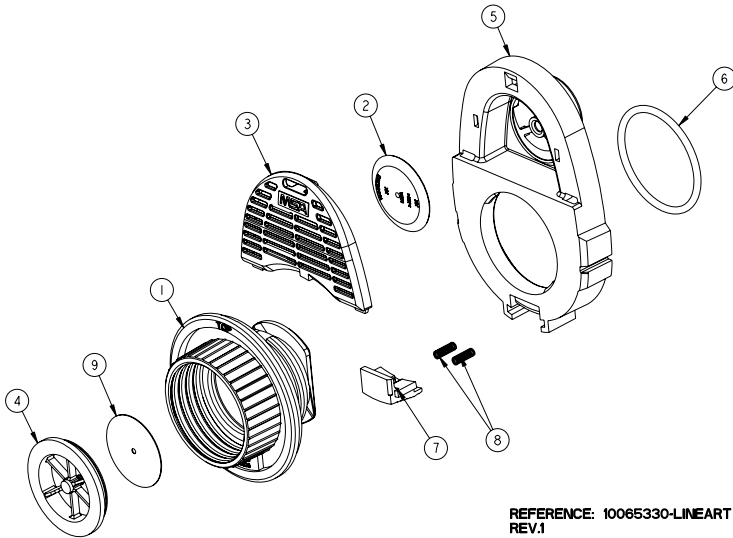

REFERENCE: 10065330-LINEART
REV.1

ADVANTAGE 4000 INLET ASSEMBLY,RD-40 COMPONENTS			
ITEM NO.	PART NUMBER	QTY REQD	DESCRIPTION
1	10065336	1	ADAPTER
2	10025295	1	VALVE, EXHALATION
3	10061974	1	COVER, EXHALATION
4	10025292	1	GASKET, SPIDER
5	10061975	1	HOUSING, COMPONENT
6	10065301	1	ORING, #128
7	10061976	1	BUTTON, LOCKING
8	10065303	2	SPRING
9	10065805	1	VALVE, INHALATION
NOT SHOWN	604070	-	LUBRICANT

