

# EVOLUTION<sup>®</sup> 5000 Thermal Imaging System

## OPERATION AND INSTRUCTIONS

### ▲ WARNING

THIS MANUAL MUST BE READ CAREFULLY BY ALL INDIVIDUALS WHO HAVE OR WILL HAVE THE RESPONSIBILITY FOR USING OR SERVICING THE PRODUCT. Like any piece of complex equipment, the unit will perform as designed only if it is used and maintained in accordance with the manufacturer's instructions. OTHERWISE IT COULD FAIL TO PERFORM AS DESIGNED AND RESULT IN SEVERE PERSONAL INJURY OR DEATH.

The warranties made by Mine Safety Appliances Company with respect to the product are voided if the product is not used and serviced in accordance with the instructions in this manual. Please protect yourself and others by following them. We encourage our customers to write or call regarding this equipment prior to use or for any additional information relative to use or repairs. During regular working hours, call 1-877-MSA-FIRE.

By order of the US Department of Commerce, in conjunction with the US Department of State and DOD, this Thermal Imaging Camera may not be resold, re-exported, transferred, or otherwise disposed of outside of the country named as the location of foreign end use, either in its original form or after being incorporated into other end items, without the prior written approval of the US Department of Commerce. Violation of this regulation may result in fine and/or imprisonment.

This manual is available on the internet at [www.msanet.com](http://www.msanet.com)



**MSA**

Be Sure.  
Choose MSA.

MINE SAFETY APPLIANCES COMPANY  
PITTSBURGH, PENNSYLVANIA, U.S.A. 15230

# Table of Contents

<b>BEFORE USE / DESCRIPTION</b> .....	<b>4</b>	Disposable Display Covers .....	11
INTRODUCTION .....	4	Custom Carrying Case .....	11
FEATURES AND BENEFITS .....	4	Mounting Bracket .....	11
DESCRIPTION .....	4	Tripod Mounting Adapter .....	11
ABOUT THE CAMERA .....	4	Tripod .....	11
Specifications .....	5	<b>Evolution 5000 Truck-Mounted</b>	
<b>WARNINGS AND CAUTIONS</b> .....	<b>6</b>	<b>Charging System Operation</b> .....	<b>12</b>
▲ WARNING .....	6	Power Status LED Indicators .....	12
▲ CAUTION .....	6	Battery LED Indicators .....	12
LIMITATIONS .....	6	<b>Evolution 5000 Truck-Mounted Charging System</b>	
<b>OPERATION</b> .....	<b>7</b>	<b>Installation</b> .....	<b>13</b>
OPERATION .....	7	Operation .....	13
Getting Started .....	7	Getting Started .....	13
TURNING THE CAMERA ON AND OFF .....	7	▲ WARNING .....	13
Normal Mode .....	7	What you will need: .....	13
Standby Mode .....	7	Installation Guidelines .....	13
Turning the Camera OFF .....	7	Mounting Hanging Channels .....	13
USER INTERFACE- INDICATORS AND WARNINGS .	7	Mounting the Truck-Mounted Charger to Channels ...	13
On-Screen Indicators .....	7	Electrical Connections .....	13
LED Indicators .....	8	Power Requirements .....	13
On-Screen Indicators .....	8	Electrical Specifications .....	13
LED Indicators .....	8	Installation .....	13
▲ WARNING .....	8	<b>WARRANTY AND SERVICE</b> .....	<b>14</b>
Additional Indicators .....	8	MSA EVOLUTION THERMAL IMAGING CAMERA	
Direct Video Connection .....	8	WARRANTY .....	14
<b>BATTERY CARE AND INSTALLATION</b> .....	<b>9</b>	<b>MAINTENANCE AND ADJUSTMENTS</b> .....	<b>15</b>
RECHARGEABLE BATTERIES .....	9	General Maintenance .....	15
BATTERY INSTALLATION AND CARE .....	9	Cleaning .....	15
BATTERY MAINTENANCE .....	9	▲ WARNING .....	15
STAND-ALONE BATTERY CHARGER .....	9	TROUBLESHOOTING THE TRUCK-MOUNTED	
▲ WARNING .....	9	CHARGING SYSTEM .....	15
OPERATION .....	9	Troubleshooting Guidelines .....	15
CHARGING THE BATTERY .....	9	▲ WARNING .....	15
<b>TIC Accessories</b> .....	<b>11</b>	▲ CAUTION .....	15
TIC Configurations and Accessories .....	11	SERVICE .....	15
Evolution 5000 TIC Standard Components .....	11	Field Repairs and Maintenance .....	16
Other Options .....	11	Internal PCB Fuse Replacement .....	16
Carrying Attachments .....	11	MSA FACTORY REPAIR & SERVICE POLICY CARD	17
Display Sun Shroud .....	11	<b>Evolution 5000 TIC SPARE PARTS LIST</b> .....	<b>18</b>
Reflective Trim Kit .....	11		

# BEFORE USE / DESCRIPTION



**Figure 1. The Evolution<sup>®</sup> 5000 TIC**

## INTRODUCTION

Congratulations on the purchase of your new MSA Evolution 5000 Thermal Imaging System! This hand-held unit provides advanced thermal imaging technology backed by years of MSA quality, dedication, and service.

The Evolution 5000 Thermal Imaging Camera (TIC) is designed to assist firefighters to see in low visibility conditions of smoke and darkness. This high definition thermal imaging camera provides the latest in available thermal imaging technology for the fire service.

## FEATURES AND BENEFITS

The Evolution 5000 Thermal Imaging Camera (TIC) can be used to aid firefighting in scenarios such as:

- Search and rescue missions
- Initial size-up/Scene assessment
- Locating the seat of the fire
- Locating fire extension
- Identifying potential flashover situations
- Determining entry and ventilation points
- Hazmat situations
- Response vehicle navigation (darkness or heavy smoke)
- Preplanning/Fire code inspections
- Overhaul
- Assistance for law enforcement

## DESCRIPTION

The Evolution 5000 TIC is a highly sophisticated piece of electronic equipment. The unit was designed to withstand the firefighting conditions of heat, driving spray, and frequent impact normally seen by a firefighter. Extension beyond these demands may damage the camera and render it inoperable. It is not recommended that

the camera run for extended periods in high-heat conditions.

The Evolution 5000 TIC is intended as an aid to fire and rescue operations in conditions of poor visibility created by smoke and darkness. It is not a replacement for standard firefighting techniques and precautions. Users must ensure that the fire department's standard operating procedures are followed while using the camera.

## ABOUT THE CAMERA

The Evolution 5000 TIC is:

- equipped with a state-of-the-art 160 x 120 microbolometer thermal detector to provide the clearest high-definition images available in fire and non-fire environments
- equipped with a large screen, high definition display to allow for multiple firefighters to view the action
- ergonomically designed for the firefighting environment
- available with desk top and truck mounted charging options
- designed with the most ergonomically correct balance, with the center of gravity located in the users hand
- dust and water-resistant to withstand short-term immersion in up to three feet of water in accordance with IP67 specifications
- Available with multiple carrying and attachment options to suit user preferences - the Evolution 5000 TIC is a tool
- The Evolution 5000 TIC detects thermal energy radiated/generated from surrounding objects and converts this energy into a visual image.
  - Hot objects appear white.
  - Cold objects appear black.



**Figure 2.**

<b>Specifications</b>		
<b>CONSTRUCTION</b>		Flame retardant (material passes simulated NFPA direct flame exposure test). IP67 [withstands immersion to 3 feet (1 meter)]
<b>APPROXIMATE DIMENSIONS</b>	<b>HEIGHT</b>	10.8 inches (275 mm)
	<b>WIDTH</b>	8.1 inches (205 mm)
	<b>LENGTH</b>	4.4 inches (112 mm)
<b>SENSOR</b>		Uncooled VOX microbolometer
<b>ARRAY SIZE</b>		160 X 120
<b>WEIGHT</b>		2.9 lbs.
<b>POWER SOURCE</b>		Rechargeable Li Ion batteries
<b>POWER USAGE</b>	<b>AT 72°F (22°C)</b>	Less than 6.0 W nominal
<b>OPERATING TIME</b>	<b>1 Li Ion PACK</b>	2 hours at nominal 72°F (22°C)
<b>FIELD OF VIEW</b>		63° diagonal; 50° horizontal
<b>NET EQUIVALENT TEMPERATURE DIFFERENCE</b>	<b>HIGH SENSITIVITY</b>	.050°C, 50 mk
	<b>LOW SENSITIVITY</b>	.389°C, 389 mk
<b>VIDEO OUTPUT</b>		RS-170

This device complies with part 15 of the FCC Rules. Operation is subject to the following two conditions: (1) This device may not cause harmful interference, and (2) this device must accept any interference received, including interference that may cause undesired operation.

# WARNINGS AND CAUTIONS

## ⚠ WARNING

1. The user must be trained and thoroughly familiar with the proper operation and limitations of the thermal imaging system prior to use. Use in controlled live-burn exercises is suggested before using the equipment in actual emergency situations. Improper use of the equipment in a hazardous atmosphere could result in serious personal injury or death.

2. Do not rely on the thermal imaging system as the sole means of navigation or deviate from standard fire-fighting navigational practices during use. Although the system provides an image in dark and smoky environments, the user may become disoriented or lost in such environments if the system becomes inoperative.

Most electronic devices will cease to operate at certain high temperature extremes. Tests on the Evolution 5000 TIC indicate that it will provide an acceptable image when subjected to an ambient temperature of approximately 120°C (248°F) for about ten minutes. Exposure to conditions exceeding these will result in deterioration and loss of image.

3. Thermal energy is **not** transmitted through glass or underwater and may be reflected off of smooth surfaces. Disorientation may occur if the user is unaware of these properties.
4. This thermal imaging system is not rated as "Intrinsically Safe." Do not use the system in environments or atmospheres where static or sparks may cause an explosion.
5. Before entering a hostile environment, test the thermal imaging system as specified in the instructions to ensure that it is functional. After each use, inspect the system to determine if servicing is required.
6. Exposure to high temperature environments for an extended period of time may cause degradation or loss of thermal image. Avoid heat saturation or over exposure of the equipment. If degradation of the thermal image is observed, immediately remove the equipment from the high heat environment and allow it to cool until the thermal image returns to normal; otherwise, the system may become inoperative.
7. Replacement batteries must exactly match the ratings and configuration of those supplied

with the equipment. Use of unapproved batteries may render the system inoperative.

8. Do not remove the thermal imaging camera cover or casing as the system operates on high voltage. Only authorized personnel may service the unit.

**FAILURE TO FOLLOW THE ABOVE WARNINGS CAN RESULT IN SERIOUS PERSONAL INJURY OR DEATH.**

## ⚠ CAUTION

1. Ensure battery is fully charged before use. If not fully charged, the system will not operate for the specified amount of time. Monitor battery level during use and immediately exit the hazardous area when a low battery warning is observed.
2. Electromagnetic radiation (radio transmissions) may cause interference. Minimize nearby radio transmissions if excessive interference occurs.
3. To avoid lens fogging, the user may coat the lenses and view finder with MSA anti-fog material (MSA P/N 13016).
4. Do not point the thermal imaging camera directly at the sun; otherwise, damage to the detector may occur.
5. Do not drop the thermal imaging camera. Although the camera is designed to withstand normal impacts that occur in fire service, such impacts may alter the focus or damage the unit.

**FAILURE TO FOLLOW THE ABOVE CAUTIONS CAN RESULT IN PERSONAL INJURY OR EQUIPMENT DAMAGE.**

## LIMITATIONS

1. Although the Evolution 5000 TIC is IP67 waterproof, the system does not provide underwater thermal images.
2. The Evolution 5000 TIC does not provide images through glass, water, or shiny objects; these surfaces act like mirrors to the system.
3. The Evolution 5000 TIC does not improve impaired vision. Users with impaired vision should continue to use ophthalmic devices while using the system.

# OPERATION

## OPERATION

### Getting Started

The rechargeable batteries supplied with the Evolution 5000 TIC must be fully charged before use. Also, periodically check and replace the battery in an actively-used imager.

- See "Battery Care and Installation" later in this manual.

### TURNING THE CAMERA ON AND OFF

#### Normal Mode

1. To turn the camera ON, press the POWER (green) button on the TIC handle (see FIGURE 3) and hold for approximately one second.
2. Wait approximately five seconds for the infrared sensor electronics to self-test.
  - The green POWER LED (located near the display) lights.
  - After several seconds, the thermal image appears on the screen.
3. Verify the camera is functioning by aiming at an object or person until the thermal image appears in the camera viewer.
  - The thermal imaging camera is now ready for use.



Figure 3. ON/OFF Button

**NOTE:** The Evolution 5000 POWER button has a momentary pushbutton switch that requires deliberate, one-second activation to activate. Rapid repeated depression of the POWER button may cause the TIC start-up software to lock, and a picture will not display (LEDs may still activate). If this condition occurs, simply turn the TIC OFF and back ON using slow, deliberate button presses.

#### Standby Mode

To conserve battery consumption, the camera is equipped with a Standby Mode feature.

4. To activate, press the POWER button until:

- The display shuts OFF.
  - The system STATUS LED begins to flash green.
5. To return to Normal Mode from Standby Mode, press the POWER (green) button until:
    - The display immediately reactivates without warm-up time.
    - The system STATUS LED turns to solid green.

#### Turning the Camera OFF

6. To turn the camera OFF, press and hold the green POWER button in for four seconds.
  - As a safety feature to avoid inadvertent power-OFFs, the green POWER button must be held for four seconds to turn OFF the camera.
  - The green STATUS LED flashes during the power-off countdown to confirm effective button press.
  - When all LED indicators shut OFF, the user may release the green POWER button.
    - The camera is now OFF.

### USER INTERFACE- INDICATORS AND WARNINGS

The Evolution 5000 TIC comes standard with five LED Indicators for System Status, Battery Life and Overtemp status. When the TIC is turned OFF, all LEDs are darkened. Also, the TIC has on-screen indicators for low sensitivity, shutter and optional quick-temp (FIGURE 4).

#### On-Screen Indicators

- A Low sensitivity firefighting mode indicator
- B Shutter indicator
- C Optional Quick - Temp Indicator and Digital Temperature Measurement

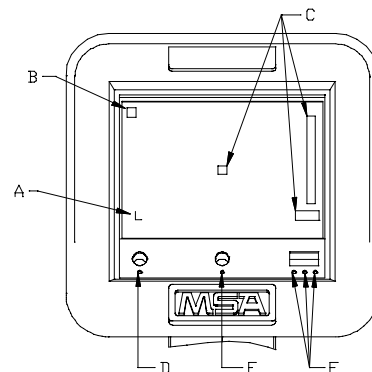

Figure 4. Evolution 5000 User Interface

## LED Indicators

- D Over - Temperature Warning
- E System Status Indicator
- F Battery Status Indicators.

## On-Screen Indicators

**A - Low Sensitivity Mode Indicator** - An on-screen sensitivity indicator ("L") informs the user when the camera is in the low sensitivity (Firefighting) mode.

- This mode occurs when the thermal imager senses an environment above 150°C.
- Dynamic Range is extended while in this mode to provide greater image details of the surroundings.

In high-heat conditions, the TIC will automatically enter the Low Sensitivity (or Firefighting) mode. While in Low Sensitivity mode, the TIC's dynamic range is extended, thereby allowing the user to make better distinction of objects and people within a higher temperature range. When the Evolution 5000 TIC is in Low Sensitivity mode, the letter "L" appears in the lower left corner of the display.

**B - Shutter Indicator** - An on-screen indicator that tells the user when the TIC is shuttering appears as a green square in the upper left corner of the display.

While the TIC is in operation, it is periodically necessary for the TIC to refresh the focal plane in order to operate properly. This occurs via an internal shutter mechanism. When the TIC shutters, the image on the display temporarily freezes for about one second. Shuttering can occur more frequently in higher heat conditions. This is normal for all microbolometer - based TICs.

**C - Optional Quick-Temp Indicator** - On-screen operating Quick Temp spotter and vertical bar gauge spans temperatures from 32°F (0°C) to 300°F (150°C) in High Sensitivity mode and 32°F (0°C) to 1000°F (500°C) in Low Sensitivity mode for objects located in the spotter. The digital temperature feature displays the approximate numeric value of the temperature of objects located in the spotter.

## LED Indicators

**D - Over Temperature Warning** - Warning activates when the system electronics approach maximum recommended operating temperature limits.

- **Not lit** indicates system is within operational thermal limits
- **Flashing Red** indicates the TIC has exceeded recommended operational thermal limits.

### **WARNING**

**Most electronic devices will cease to operate at certain high temperature extremes. Tests on the Evolution 5000 TIC indicate that it will provide an acceptable image when subjected to an ambient temperature of approximately**

**120°C (248°F) for about ten minutes. Exposure to conditions exceeding these will result in deterioration and loss of image.**

**E - System Status Indicator** - A single LED shows the operational status of the TIC.

- **Green** indicates the TIC is ON and fully operational
- **Flashing Green** indicates the TIC is ON and in power-saving Standby mode.

**F - Battery Status Indicator** - Battery capacity is shown by a row of three LEDs: one green, one yellow, and one red. Only one of the three battery status indicators will be illuminated at any one time.

- **Green** indicates full or nearly full battery capacity
- **Yellow** indicates marginal battery capacity
- **Red** indicates battery warning and nominally 15 minutes of battery life remaining
- **Flashing Red** indicates battery shutdown is imminent (about one minute of warning time).

## Additional Indicators

**Optional Heat Seeker Indicator** - The optional Heat Seeker indicator shows any portion of the screen in red:

- When in high sensitivity mode (low temperatures) any portion of the scene which is above 288°F (142°C)
- When in low sensitivity mode (firefighting mode) any portion of the scene which is above 887°F (475°C)

The Heat Seeker mode also indicates any portion of the scene in yellow:

- When in high sensitivity mode (low temperatures) any portion of the scene which is above 275°F (135°C)
- When in low sensitivity mode (firefighting mode) any portion of the scene which is above 842°F (450°C).

**System Fault Indicator** - All five LEDs will flash if a system fault is detected. The TIC's internal computer runs a self-diagnostic program. If a problem with the internal component is detected, a fault will be signaled and the LEDs will flash.

## Direct Video Connection

If you plan to use the TIC for viewing or recording direct video, the Evolution 5000 TIC is equipped with an SMA-type video out connector located below the display, next to the handle. Also included is an adapter cable to a BNC connection (FIGURE 5).

If you plan to use the video out capability, attach the SME connector end and rout the adapter cable to and through the front handle. The unit can then be quickly attached to a video display using a BNC connection.



**Figure 5. TIC with SMA to BNC Connector**

# BATTERY CARE AND INSTALLATION

## RECHARGEABLE BATTERIES

The Evolution 5000 TIC runs on two Lithium Ion batteries; one battery is required for TIC operation.

## BATTERY INSTALLATION AND CARE

1. Place the unit on a clean, non-abrasive surface and lean the unit forward.
2. Unhook the battery latch and open the battery compartment.
3. Place the battery inside the battery compartment with the battery logo and arrow facing right and pointing toward the top of the TIC.
4. Close and latch the battery compartment.

## BATTERY MAINTENANCE

After each use, inspect:

- battery contacts for damage
- batteries for damage or leakage
- to ensure battery charger is functioning properly by:
  - placing battery into the charger
  - checking that the battery charger LEDs react accordingly.

**Note:** Batteries not passing this inspection must be removed from service until the proper repairs are made.

## STAND-ALONE BATTERY CHARGER

### **⚠ WARNING**

This charging system is not rated as "intrinsically safe." Do not use the system in environments or atmospheres where static or spark may cause an explosion.

Do not remove the outer housing of the Charger. Only authorized personnel may service the unit.

The Charger must only be used for charging Evolution rechargeable Lithium Ion Battery Packs.

Do not use damaged chargers.

Do not attempt to charge damaged packs.

Do not use the charger outdoors.

**FAILURE TO FOLLOW THE ABOVE WARNING CAN RESULT IN SERIOUS PERSONAL INJURY OR DEATH.**

## OPERATION

Choose the proper adapter cord power source to be used.

1. **For standard AC operation:**  
Plug the DC plug of the AC/DC Adapter into the charger and plug the AC Adapter into any standard 110-VAC outlet.
2. **For DC Power Adapter operation:**  
Plug the DC Power Adapter Cord into the charger and plug the other end into any DC 12-V power source that offers a cigarette-lighter type socket.

## CHARGING THE BATTERY

1. Connect the unit with either AC/DC Power Adapter or DC Car Power Adapter.
2. Place the battery into the unit.
  - **StandBy Mode:**
    - Without any battery installed, the charger will flash the LED marked MED, indicating that the charger is standing by and waiting for a battery to be connected.
  - **Phase 1 - Initial Charge:**
    - All three LEDs flash in sequence from MED (left) to MAX (right)
    - If the battery is low, this will be the first charge phase
    - With high capacity batteries, this phase can sometimes be the longest of the three phases
    - With some low capacity batteries and batteries reaching the end of their life, this phase can be very short.

**Note:** When a battery is first connected, the LEDs may instantly indicate MED, HI and MAX charge, depending on the charge status of the battery. The process will continue normally from that point forward.



**Figure 6.**



**Note:** It is normal for the charger, AC adapter, or the battery to become warm during charging.

• **Phase 2 - MED Charge:**

- MED LED is ON continuously and other LEDs are flashing in sequence
- At this point, the battery is typically about 50% charged.

• **Phase 3 - HI Charge:**

- The MED and HI LEDs are ON and the MAX LED is flashing
- At this point, the battery is typically about 70% charged.

• **Phase 4 - MAX Charge:**

- All three LEDs are ON at the same time
- Charging is complete and the battery is fully charged
- It is recommended to remove the battery at this time.

3. Remove the battery from the unit.

- The battery is now ready for use.

**Note: Error Condition - Charge Terminated -**

If the battery is removed before a complete charge is reached, the charger continues indicating the last complete charging phase for up to one minute. After that time, an "Error" indication appears on the LEDs (shown by the MED and MAX LEDs coming ON together while the HI LED is OFF).

The Error Condition is also indicated if the charger senses any problem with the battery being charged. To reset the Error Condition, unplug the charger from the power adapter for a few seconds; then, reconnect the charger to the power adapter. If the Error occurs again, there may be a defect in the battery that prevents safe charging.

# TIC Accessories

## TIC Configurations and Accessories

The Evolution 5000 TIC can be purchased as a complete kit with accessories or can be custom configured to your requirements under the Assemble to Order (ATO) System. There are several part-numbered kits to choose from. Please see the Evolution 5000 Brochure for complete ordering information.

## Evolution 5000 TIC Standard Components

All Evolution TICs come standard with the following items:

- Thermal Imaging Camera
- Two Rechargeable Lithium Ion Batteries
- Caribiner Attachment
- Standard Universal Charger Kit with Cigarette Lighter Adapter or truck Mounted Charger
- Care and Use Video
- SMA Video Out Connector.
- Instruction Manual

The Evolution 5000 TIC can be ordered as standard kit part numbers or as Assemble to Order. See ordering information.

## Other Options

### Carrying Attachments

The Evolution 5000 Thermal Imaging Camera (TIC) comes standard with a caribiner attachment. Additionally, users can choose to purchase any one of three optional carrying attachments:

- **Wrist Strap/Bunker Clip** - Attaches to the TIC and includes a clip for securing the TIC to bunker gear while not in use.
- **Shoulder strap** - Attaches to the TIC to allow for easy carriage of the camera while not in use.
- **Retractable Lanyard** - Attaches to the TIC to allow for easy carriage and quick use of the camera while attached to the user's belt or gear. Lanyard easily retracts the camera back into place when not in use.

### Display Sun Shroud

Display Shroud allows for crisp/clear viewing of the LCD screen while in bright sunlight.

## Reflective Trim Kit

Reflective Trim allows the user to add additional visibility for the Evolution 5000 TIC.

**NOTE:** It is NOT recommended that reflective trim pieces be placed on the main camera housing if the TIC is used with a truck-mounted charger, as it may interfere with making adequate contact.

## Disposable Display Covers

A package of three Disposable Display Covers provides replaceable protection of the 3.5" LCD.

## Custom Carrying Case

The Durable Carrying Case allows for storage and transport of the TIC, batteries, charger, and carrying attachments.

## Mounting Bracket

The Non-Charging Mounting Bracket enables convenient storage of the Evolution 5000 TIC.

## Tripod Mounting Adapter

The Tripod Mounting Adapter allows for mounting of the TIC onto any standard tripod.

## Tripod

The Tripod allows for stationary viewing of the thermal imaging camera. The Tripod must be used with the Tripod Adapter.



**Figure 7.**

# Evolution 5000 Truck-Mounted Charging System Operation

To charge the TIC and spare batteries using the Evolution 5000 Truck-Mounted Charging System make sure the TIC charging pins and cradle are clean and free from debris.

1. Place the TIC into the charging cradle with the display facing outward; secure the unit with the straps on the charging cradle.
2. If charging a spare battery, place the battery into the slot provided and secure it with the rubber retainer.

The power LED indicator should always remain green when the power source is ON and properly connected. When the Truck-Mounted Charging System is correctly installed, the status indicators will light as follows:

Power Status LED Indicators	
OFF	System Fault
GREEN	Power On/ System Operational
Any LED indication other than those listed indicates faulty operation and the unit must be returned to MSA for service.	

Battery LED Indicators	
OFF	No Battery Installed
GREEN	Charge Completed
FAST BLINKING GREEN	Charging
SLOW BLINKING GREEN	Charge Pending
RED	Fault
Any LED indication other than those listed indicates faulty operation and the unit must be returned to MSA for service.	

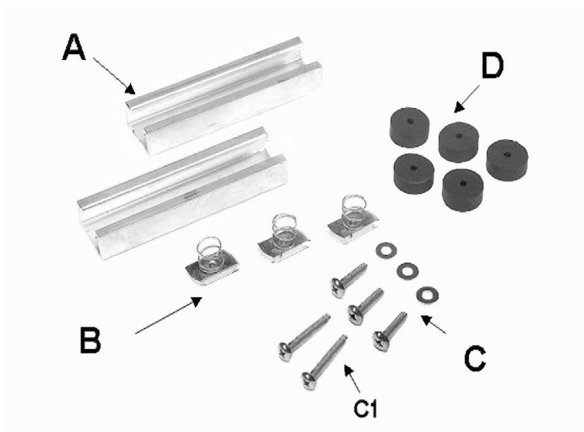

**Figure 8.**

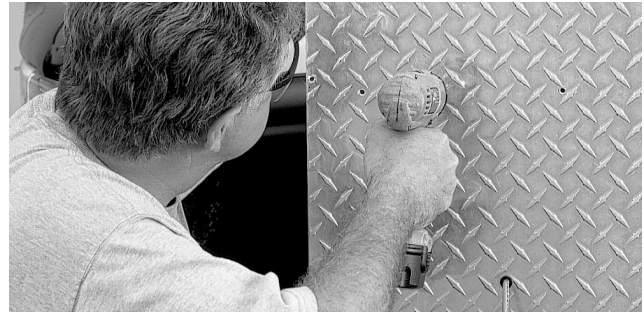

**Figure 9.**

**Note:** For optimal performance, the battery charger should be operated at temperatures between 50 to 85° F (10 to 29° C). Charging batteries outside this temperature range may result in a charging error and/or premature battery degradation. Charging batteries in environments greater than 100° F (38° C) may result in premature termination of charge.

The charging cycle takes approximately 2-1/2 hours to completely charge a single battery or five hours when charging two completely discharged batteries.



**Figure 10.**

# Evolution 5000 Truck-Mounted Charging System Installation

## Operation

### Getting Started

The Evolution 5000 TIC Truck-Mounted Charging System must be correctly installed before use. Read all installation instructions thoroughly before starting actual installation.

#### **⚠ WARNING**

**Carefully follow all instructions provided with this charger. This charger will perform as designed only if installed, used, and maintained properly; otherwise, it may fail to operate properly and result in serious personal injury or death.**

**Use eyewear or face protection to avoid eye injury during installation; failure to do so may result in serious personal injury.**

### What you will need:

- Electric drill
- #7 (.201) drill bit, 9/32 (0.281) drill bit
- 1/4-20 tap
- #2 Phillips head screwdriver
- Stainless steel 1/4- 20 bolts (4)
- 5-amp in-line fuse
- Master ON/OFF switch
- Strain relief bushing for power supply cable
- Installation hardware kit (provided).

### Installation Guidelines

Select a large flat surface area for mounting that allows easy access for Evolution 5000 TIC storage and adequate cable length for electrical connections. Take care to install the charger in an area protected from direct water spray and extreme temperature conditions.

### Mounting Hanging Channels

1. Drill two holes in both Unistrut channels (**A** in FIGURE 8), using a 9/32 (.281) drill.
  - Drill mounting holes, 1-1/2 inches in from outside edges of channels.
2. Place top channel on the cab wall, approximately four inches away from overhead obstructions.
3. Using a Unistrut channel as a template, drill two holes into cab wall with a #7 (.201) drill.
4. Tap both holes for 1/4-20 mounting bolts.
5. Position bottom channel on cab wall, 6-1/2 inches away from center of top channel.

6. Repeat steps 3 and 4 to mount bottom channel.
7. Bolt both channels in-place with stainless steel 1/4-20 bolts.

### Mounting the Truck-Mounted Charger to Channels

1. Slide Unistrut spring nut (**B** in FIGURE 8) into channel and rotate 90° to seat nut in channel V-groove. One nut is required for the top channel and two for the bottom channel.
2. Place the stainless steel bolts (**C** in FIGURE 8) through the mounting holes molded into the charger.
3. Place the neoprene rubber washer (**D** in FIGURE 8) over the bolt, align bolt with spring nut and tighten.

**Note:** If mounting the charger vertically, use the two longer stainless steel bolts on the bottom and add a second neoprene washer to each of the bottom two bolts.

### Electrical Connections

#### Power Requirements

The Truck-Mounted Charging System can consume enough current to eventually fully drain the vehicle's battery, if the vehicle stands for longer than a 12-hour period without supplemental battery charging.

Therefore, it is recommended that the charger be installed using any master ON/OFF switch where power comes directly from the battery, supplemental charger or connected to AC power via a shoreline when the vehicle is stored.

Electrical Specifications	
INPUT VOLTAGE RANGE	12.5 to 26.0 VDC (Fused at source)
INPUT CURRENT	Less than 2.0 Amps DC
NORMAL BATTERY CHARGE TIME	2.5 Hours

### Installation

1. Connect the positive lead (red) on the prepared wire end of the power supply line to a fused, in-line connection with a master switch. Connect to the switched side of ignition or power source.
2. Connect the negative lead (black) of power supply line to a confirmed ground.
3. With power source ON, confirm that the power LED light is GREEN. If any other result occurs, see "Troubleshooting Guidelines" in the "Maintenance, Troubleshooting and Service" section of this manual.

# WARRANTY AND SERVICE

## MSA EVOLUTION THERMAL IMAGING CAMERA WARRANTY

1. Warranty - Seller warrants that this product and its accessories will be free from mechanical defect or faulty workmanship for a period of one (1) year from date of purchase, not to exceed eighteen (18) months from date of manufacture, which ever occurs first, provided it is maintained and used in accordance with Seller's instructions and/or recommendations. The Seller shall be released from all obligations under this warranty in the event repairs or modifications are made by persons other than its own or authorized service personnel or if the warranty claim results from physical abuse or misuse of the product. No agent, employee or representative of the Seller has any authority to bind the Seller to any affirmation, representation or warranty concerning the goods sold under this contract. THIS WARRANTY IS IN LIEU OF ALL OTHER WARRANTIES, EXPRESSED, IMPLIED OR STATUTORY, AND IS STRICTLY LIMITED TO THE TERMS HEREOF. SELLER SPECIFICALLY DISCLAIMS ANY WARRANTY OF MERCHANTABILITY OR OF FITNESS FOR A PARTICULAR PURPOSE.

2. Exclusive Remedy - It is expressly agreed that Purchaser's sole and exclusive remedy for breach of the above warranty, for any tortious conduct of Seller, or for any other cause of action, shall be the repair and/or replacement at Seller's option, of any equipment or parts thereof, which after examination by Seller is proven to be defective. Replacement equipment and/or parts will be provided at no cost to Purchaser, F.O.B. Seller's Plant. Failure of Seller to successfully repair any nonconforming product shall not cause the remedy established hereby to fail of its essential purpose.
3. Exclusion of Consequential Damage - Purchaser specifically understands and agrees that under no circumstances will seller be liable to purchaser for economic, special, incidental or consequential damages or losses of any kind whatsoever, including but not limited to, loss of anticipated profits and any other loss caused by reason of non-operation of the goods. This exclusion is applicable to claims for breach of warranty, tortious conduct or any other cause of action against seller.
4. Extended Service Options - Extended Warranty options available by request. Please contact your MSA representative for additional information.

# MAINTENANCE AND ADJUSTMENTS

## General Maintenance

After each use, inspect:

- the Evolution 5000 TIC for structural, heat and/or chemical damage
  - the mechanical hardware to ensure no screws are loose and no O-rings or gaskets are loose or misplaced
  - all lenses for heat damage, chemical damage, cracks and breaks
  - to ensure that all warning labels are intact
  - battery - see "Battery Care and Installation"
- Note:** Thermal Imaging Cameras not meeting the above inspection must be removed from service until the proper repairs are made.
- charger and TIC LEDs for proper indication that the system is operating properly.

## Cleaning

After each use, clean all external surfaces (case, base, visor, lens, window and straps) by wiping with a solution of mild detergent and warm water. Dry with a soft, lint-free cloth, to avoid scratching the optical surfaces.

Periodically check connector terminals, video socket, ON/OFF switch, locking latch and hinge for contamination. Clean with a soft, lint-free cloth.

### ⚠ WARNING

Do not remove the thermal imaging camera cover or casing as the system operates on high voltage. Only authorized personnel may service the unit.

**FAILURE TO FOLLOW THE ABOVE WARNING CAN RESULT IN SERIOUS PERSONAL INJURY OR DEATH.**

## TROUBLESHOOTING THE TRUCK-MOUNTED CHARGING SYSTEM

Troubleshooting Guidelines	
SYMPTOM	PROBLEM/SOLUTION
NO LEDS LIT	Check power connections. Is power available?
	Is the positive power lead connected to the positive terminal?
	External in-line fuse blown. Replace fuse.
	Internal fuse blown. Replace fuse.

(L) Rev. 2 - 10038652

Troubleshooting Guidelines	
SYMPTOM	PROBLEM/SOLUTION
POWER LED STATUS IS GREEN AND CAMERA BATTERY LED DOES NOT LIGHT WHEN CAMERA IS PLACED IN CHARGER	No batteries installed in the camera. Verify that there are good batteries in the camera.
	Bad connection to the camera. Make sure charger contacts are clean and unbent. A small amount of contact cleaner, such as WD-40 can be used to clean charger and camera charging contacts. Reseat firmly to ensure connection.
POWER LED STATUS IS GREEN AND EXTERNAL BATTERY LED DOES NOT LIGHT WHEN BATTERY IS PLACED IN CHARGER	Inspect battery contacts for dirt, corrosion or damage. Clean contacts or replace battery. Inspect the contacts of the battery charger. Verify they are clean, unbent, and move down and spring back.
BATTERIES DO NOT FULLY CHARGE	Out of operating temperature range. Check that temperature of environment and /or batteries is within recommended operating range.
	Power source is noisy. Ensure power hookup cable is connected to a clean source without excessive voltage spikes.

### ⚠ WARNING

It is possible that charge can be terminated abnormally. While this condition is rare, it can occur because of external in-band noise that may reach the charger electronics. In the unlikely event that charge is falsely terminated because of noise, the battery may not fully charge. Always use the camera battery gauge as an indicator of battery condition.

### ⚠ CAUTION

Do not use solvents or paint thinners to clean the Thermal Imager; otherwise, the protective case may become degraded.

## SERVICE

If your Evolution 5000 Thermal Imaging Camera (TIC) is in need of service or repair, please contact the MSA Service Center at 1-877-MSA-FIRE.

Describe the problem to the Representative as completely as possible.

1. Verify with your Representative that the product should be returned to MSA.
2. Before returning the product, decontaminate and clean your Thermal Imaging Camera to remove any hazardous materials that may have settled on the product during use.

- Laws and/or shipping regulations prohibit the shipment of hazardous or contaminated materials.
- Products suspected of contamination will be professionally decontaminated at the customer's expense before servicing.
- Ship returned products (including those under warranty) with pre-paid transportation charges; MSA cannot accept returned goods on a freight-collect basis.

## Field Repairs and Maintenance

**Note:** Only remove the Truck-Mounted Charging System's back cover in an ESD-protected area with personal grounding system (e.g., grounded wrist strap).

### Internal PCB Fuse Replacement

- Power LED will not light and other troubleshooting guidelines do not resolve the problem.

1. Remove charger from mounting brackets. Using a screwdriver, remove the three retaining clips from the plastic bosses and remove the back cover.
2. Disconnect the power hookup cable by disconnecting the Phoenix connector from the plug-in receptacle on the upper right side of the printed circuit board panel.
3. The internal printed circuit board fuse is located next to the Phoenix connector on the circuit board. Remove the fuse using the plastic, nonconductive tweezers and replace it with a new fuse (P/N 10041101, package of five)
4. Reconnect the power hook-up cable to the Phoenix connector and replace the back cover. Secure the cover with the retaining clips and bolt it back to the mounting brackets.

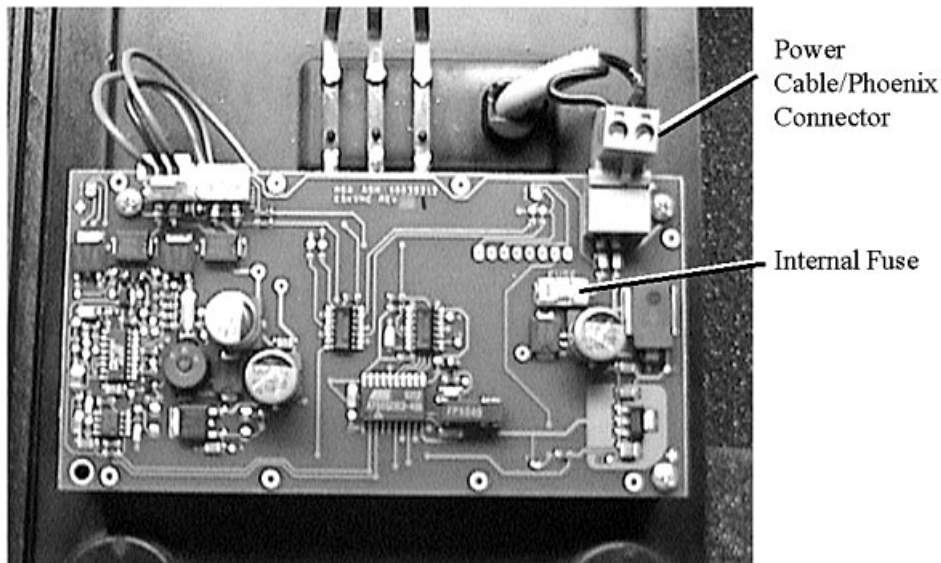

**Figure 11.**  
**Location of Power Cable, Phoenix Connector, and Internal Fuse**

# MSA FACTORY REPAIR & SERVICE POLICY CARD

To help process your repair requests, please provide the following information:

*Please complete this form in full. Thank you.*

Customer's Billing Address:		Customer's Shipping Address:	
Company Name:		Company Name:	
Street/P.O. Box:		Street Address:	
City/State/Zip:		City/State/Zip:	
Contact Name:		Phone Number:	
Product Name:		Fax Number:	
Model Number:		Your PO Number	
<b>To save time</b> - please check <b>ONE</b> of these alternatives:		Description of problem/special instructions:	
<input type="checkbox"/>	Repair and return (PO Number must be provided)		
<input type="checkbox"/>	Estimate required before repair		
<input type="checkbox"/>	Warranty Claim (Orig. MSA Invoice No. _____)		
<input type="checkbox"/>	Medical RA No. _____		
Authorized by:		Title:	Date: - - -

**FOR CALIBRATION OR REPAIR, PLEASE PROVIDE THE INFORMATION REQUESTED ABOVE. PLEASE USE A SEPARATE SHEET FOR EACH INSTRUMENT.**



# Evolution 5000 TIC SPARE PARTS LIST

PART NUMBER	SPARE PART
10041100	Charger 110 VAC with Cigarette Lighter Adapter
10038412	Lithium Ion Battery
10038977	Evolution 5000 Truck-Mounted Charging System
10039516	Wrist Strap
10039515	Shoulder Strap
10040226	Retractable Lanyard
10040005	Caribiner
10039603	Sun Shroud
10040163	Reflective Trim Kit
10038970	Disposable Display Covers
10039602	Non-Charging Mounting Bracket
10040223	Carrying Case
10040229	Tripod Mount
10018996	Tripod Kit
10040004	Video Out Cable SMA to BNC
10020290	10 Foot Auxiliary BNC Cable
10038652	Instruction Manual
10041101	Fuses, Truck-Mounted Charger (package of five)
10040222	Evolution 5000 Mounting Kit