



# Modbus Communication Protocol for SafEye™ Open Path Gas Detection System

## Technical Manual

### WARNING

THIS MANUAL MUST BE CAREFULLY READ BY ALL INDIVIDUALS WHO HAVE OR WILL HAVE THE RESPONSIBILITY FOR USING OR SERVICING THE PRODUCT. Like any piece of complex equipment, this instrument will perform as designed only if it is used and serviced in accordance with the manufacturer's instructions. OTHERWISE, IT COULD FAIL TO PERFORM AS DESIGNED AND PERSONS WHO RELY ON THIS PRODUCT FOR THEIR SAFETY COULD SUSTAIN SEVERE PERSONAL INJURY OR LOSS OF LIFE.

The warranties made by Mine Safety Appliances Company with respect to the product are voided if the product is not used and serviced in accordance with the instructions in this manual. Please protect yourself and others by following them. We encourage our customers to write or call regarding this equipment prior to use or for any additional information relative to use or repairs.

In North America, to contact your nearest stocking location, dial toll-free 1-800-MSA-INST To contact MSA International, dial 1-412-967-3354.

© MINE SAFETY APPLIANCES COMPANY 2007 - All Rights Reserved

This manual is available on the internet at [www.msanet.com](http://www.msanet.com)

Manufactured by

## MSA NORTH AMERICA

P.O. Box 427, Pittsburgh, Pennsylvania 15230

# Table of Contents

<b>Chapter 1,</b>	
<b>General Information</b> .....	<b>1-1</b>
Overview .....	1-1
Protocol Mode of Operation .....	1-1
Document Overview .....	1-1
Reference Documents .....	1-1
<b>Chapter 2,</b>	
<b>Hardware Specifications</b> .....	<b>2-1</b>
Figure 2-1. RS-485 Wiring Connections .....	2-1
<b>Chapter 3,</b>	
<b>Communication Conventions</b>	
<b>and Detector Address Setting</b> .....	<b>3-1</b>
Communication Conventions .....	3-1
Detector Address Setting .....	3-1
<b>Chapter 4,</b>	
<b>Message Format</b> .....	<b>4-1</b>
General .....	4-1
General Request (Query) Formats .....	4-2
Message Bytes Description .....	4-2
General Detector Response Message Format .....	4-3
Message Bytes Description: .....	4-3
<b>Chapter 5,</b>	
<b>Supported Modbus Commands</b> .....	<b>5-1</b>
Table 5-1. Supported Function Codes .....	5-1
Table 5-2. Possible Exception Codes .....	5-1

**Chapter 6,  
Input Registers .....6-1**

Table 6-1. Input Registers .....6-1  
Table 6-2. Detector Type Codes  
(Register 30,001) .....6-3  
Table 6-3. Status (Register 30,003)  
Codes Discrete Mode .....6-3  
Table 6-4. Relay Status (Register 30,010) Bits ..6-4

**Chapter 7,  
Holding Registers .....7-1**

Table 7-1. Holding Registers .....7-1  
Table 7-2. Window Heater Mode (40,004)  
Register Possible Values .....7-2  
Table 7-3. Mode Selector (40,017)  
Register Possible Values .....7-3  
The Setup Register .....7-3  
Table 7-4. Status (40,002) Register -  
Bit Description .....7-4  
Table 7-5. Setup (40,002) Register -  
Gas Type Configuration .....7-5  
Table 7-6. Setup (40,002) Register -  
Full Scale Configuration .....7-5

**Chapter 8,  
Practical Examples .....8-1**

Reading Detector Status .....8-1  
Setting Detector Setup .....8-2  
Reading Detector Setup .....8-3  
Setting Detector Address and Setup .....8-4

# Chapter 1, General Information

## Overview

This document defines the communication protocol for the SafEye 800 series of detectors.

## Protocol Mode of Operation

- RTU (Remote Terminal Unit)
- CRC method of communication error checking (Cyclical Redundancy Check).

## Document Overview

This document:

- describes the serial interface between a SafEye detector and an external monitoring and control system, such as a PC or an industrial controller
- provides the information necessary for the system or software designer to implement the appropriate interface.

## Reference Documents

- 1 "SafEye Xenon 800 Open Path Gas Detection System Instruction Manual", MSA P/N 10055711
- 2 Electronic Industries Association (EIA) STANDARD RS-485, Electrical Characteristics of balanced voltage digital interface circuits
- 3 "Modicon Modbus Protocol Reference Guide", MODICON Inc, document No PI-MBUS-300, Rev. J, June 1996.

## Chapter 2, Hardware Specifications

The following information provides hardware specifications for the interface between a SafEye Detector and a PC (or any other Modbus controller):

- The physical link between the controller and the detector is RS-485 (see Chapter 1, reference document number 2 for details)
- The protocol is asynchronous with the following parameters:
  - 1 start bit
  - 8 data bits
  - no parity bit
  - 1 stop bit
- Baud rate is 9600 bps
- Lines are half-duplex for multi-drop serial bus connection
- There is no data flow control.

The communication network scheme is shown in FIGURE 2-1. To ensure quality RS485 communications, also daisy-chain the RS485 return connection (pin 9) to the controller.

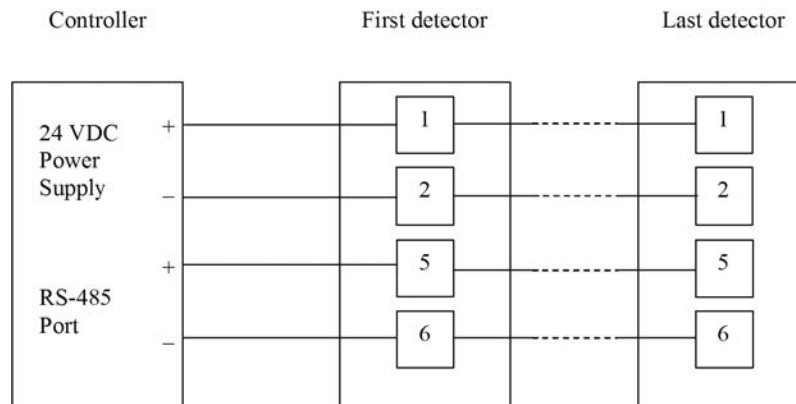

**Figure 2-1. RS-485 Wiring Connections**

# **Chapter 3, Communication Conventions and Detector Address Setting**

## **Communication Conventions**

The Modbus communication between the controller and the detector is always initiated by a message transmitted by the controller.

- The detector operates as a slave station in the communication network
- The controller operates as a master station.

All detectors on the network accept the message, but only the detector whose address is specified in this message responds.

Since only one master device is involved in a given network, only the detector's address is specified in a message format, regardless of the communication direction.

- When a communication format error is detected:
  - no error correction is performed
  - the message is discarded
  - both sides reset their configuration for reception
  - controller initiates communication.
- If no communication error occurs, but the detector cannot handle the message due to an illegal/unsupported request:
  - the detector returns an exception response.

The possible detector addresses vary in a range of 1 to 247.

Address 0 is reserved to be used for broadcasting messages (i.e., all detectors act upon a call to address 0).

## **Detector Address Setting**

Each detector within a network is assigned a unique address held in register 40,001 of the detector.

The address can be set to a number in the range 1-247 by using Modbus function code 6 or 16 (see example in Chapter 8, "Setting Detector Address and Setup").

# Chapter 4, Message Format

## General

The controller performs the following functions:

- Requests data (register contents) from the detector
- Changes the detector's holding register values
- Polls the detector.

From the detector's side, messages are used to:

- Send requested data back to the controller
- Acknowledge a requested change to the holding registers
- Respond to the controller's polling
- Report certain errors in the controller message (such as an attempt to call an unsupported function).

Modbus conventions in Message format:

- Every message is preceded by a four-character-length communication silence.
- The error checking field is calculated according to a standard algorithm, called CRC16 (Cyclical Redundancy Check); see Chapter 1, reference document number 3.
  - It occupies the last two bytes of the message.
  - The low byte of CRC is sent first.
- The end of message is established only after a delay of four characters.

## General Request (Query) Formats

The controller sends a query to a detector with the following command format (n = the number of bytes sent):

- Byte 0                    Detector Address
- Byte 1                    Function Code
- Byte 2                    Data (specific for each function code)
- . . .
- Byte n-2                 CRC - low byte
- Byte n-1                 CRC - high byte.

## Message Bytes Description

### Byte 0: Detector Address

- 0 -                    The message is:
  - broadcast to all detectors in the network
  - acted upon by all detectors in the network
- 1..247 -             Address of a specific detector.

### Byte 1: Function Code

- The function to be performed.

### Bytes 2 - n-3 : Data

- Dependent on function code  
(see Chapter 5, "Supported Modbus Commands")
- Note that Words are sent MSB first.

### Byte n-2, n-1 : CRC

- CRC-16 (Cyclical Redundancy Check):
  - Used for communication error detection.

## General Detector Response Message Format

Every Controller query is followed by a Detector response message that is addressed, except when:

- A communication error occurred.
- The query is a broadcast (a call to address 0).

A Detector response to the Controller message is in the following format (n = the number of bytes sent):

- Byte 0                    Detector Address
- Byte 1                    Function Code
- Byte 2                    Data (specific for each function code)
- . . .
- Byte n-2                 CRC - low byte
- Byte n-1                 CRC - high byte.

## Message Bytes Description

### Byte 0: Address

- 1..247 -  
    The Detector address

### Byte 1: Function Code

- The function code performed (echo of the function code received)

### Bytes 2 - n-3 : Data

- Data format depends on the query
- Words are sent MSB first

### Byte n-2, n-1 : CRC

- CRC-16 (Cyclical Redundancy Check) –  
    Used for communication error detection

## Chapter 5, Supported Modbus Commands

The detectors support the following Modbus function codes shown in TABLE 5-1:

**Table 5-1. Supported Function Codes**

CODE		NAME
(DEC)	(HEX)	
3	03	Read Holding Registers
4	04	Read Input (read only) Registers
6	06	Preset Single Holding Register
16	10	Preset Multiple Holding Registers

The detectors return exception responses as shown in TABLE 5-2:

**Table 5-2. Possible Exception Codes**

CODE	NAME	DESCRIPTION
01	Illegal Function	The received function code is not supported by the detector
02	Illegal Data Address	The query attempts to read or preset a register that is not in the allowable address range
03	Illegal Data Value	The query attempts to preset a value that is not allowable for the specific register

## Chapter 6, Input Registers

- TABLE 6-1 lists the input (read only) registers of the detector.
- These registers are read using function code 4.

**Table 6-1. Input Registers**

REGISTER	ADDRESS (HEX)	SIZE (BYTES)	NAME	DESCRIPTION
30,001	0000	1	Detector Type	See note 2
30,002	0001	2	Serial No.	The unit's serial number.
30,003	0002	1	Status	Detection status (see note 3)
30,004	0003	2	Gas Reading - %LELxmeter	See note 4
30,005	0004	1	Gas Reading - %Full Scale	Percent of the full-scale, i.e., 0 for no gas, and 100 for a reading of full-scale or above
30,006 - 30,008	0005 - 0007	6	-	Reserved for future use
30,009	0008	2	Detailed Status	See note 5
30,010	0009	1	Gain	Electronic gain level
30,011	000A	2	Reference	
30,012	000B	2	Signal 1	
30,013	000C	2	Signal 2	
30,014	000D	2	Ratio 1	
30,015	000E	2	Ratio 2	
30,016	000F	2	Norm. Ratio 1	
30,017	0010	2	Norm. Ratio 2	
30,018	0011	2	Gas Reading - %LELxmeter	See note 4
30,019	0012	2	Ref / Noise	
30,020	0013	2	Signal 1 / Noise	
30,021	0014	2	Signal 2 / Noise	
30,022	0015	1	Temperature	Internal temperature of the detector (See note 6)
30,023	0016	2	Voltage	Supply voltage (See note 7)
30,024 - 30,025	0017 - 0018	4	Total Operating Hours	See note 8
30,026	0019	1	Relay Status	See note 9
30,027	001A	1	Window Heater Status	0 - Window heating is OFF; 1 - Window heating is ON

REGISTER	ADDRESS (HEX)	SIZE (BYTES)	NAME	DESCRIPTION
30,028 – 30,032	001B – 001F	10	–	Reserved for future use
30,033	0020	2	Full Scale	In %LEL x meter
30,034	0021	2	Warning Level	In %LEL x meter
30,035	0022	2	Alarm Level	In %LEL x meter
30,036	0023	2	Obscuration Delay	
30,037 – 30,040	0024 – 0027	8	–	Reserved for future use
30,041	0028	1	Fault 4-20 mA	See note 3
30,042	0029	1	Alignment 4-20 mA	See note 3
30,043	002A	1	Obscuration 4-20 mA	See note 3
30,044	002B	1	Maintenance 4-20 mA	See note 3
30,045	002C	1	Block 4-20 mA	See note 3
30,046	002D	1	Normal 4-20 mA	See note 3
30,047	002E	1	Warning 4-20 mA	See note 3
30,048	002F	2	Alarm 4-20 mA	See note 3
30,049 – 30,256	0030 – 00FF	416	–	Reserved for future use
30,257 - 30,288	0100 – 011F	64	Version	The detector's software version (Null terminated string)

**NOTES:**

1. Since all registers are words (2-byte long):
  - A Dummy byte (0x00) is added to each byte requested
  - 4-byte long parameters are divided into two registers:
    - The first register is the most significant
    - It is the controller programmer's responsibility to read both such registers in a single query.
2. TABLE 6-2 defines the possible detector type codes (register 30,001 values).

**Table 6-2. Detector Type Codes (Register 30,001)**

CODE (HEX)	DETECTOR TYPE
0118	SafEye 801 (short range)
0218	SafEye 802 (mid. range)
0318	SafEye 803 (long range)

3. The “Status” register (no. 30,003) represents the value of the detector’s 4-20 mA output. The register’s “Fault 4-20 mA” to “Alarm 4-20 mA” (no. 30,041-30,048) show the 4-20 mA values output during the Fault to Alarm states, respectively, (if the 4-20 mA output is configured to the discrete mode); see TABLE 6-3.

The values of all these registers represent the 4-20 mA output current in 0.1 mA units (the value in mA multiplied by 10).

The detector can be configured to output its state in two modes: continuous and discrete (see TABLE 7-3). TABLE 6-3 shows the default values of the 4-20 mA output and the status register for different detector states in the discrete mode.

**Table 6-3. Status (Register 30,003) Codes Discrete Mode**

STATE	4-20 mA OUTPUT	STATUS REGISTER (30,003)
Fault	0	0
Alignment	1	10
Block / Obscuration	2	20
Maintenance Call	3	30
Normal	4	40
Warning	14	140
Alarm	19	190

A detector, configured to the continuous mode, has the same 4-20 mA and status register (30,003) values (shown in TABLE 6-3) for the: “fault”, “alignment”, “block/obscuration” and “maintenance call” modes. For the “normal”, “warning” and “alarm” modes, the detector outputs a value between 4 and 20 mA (40-200 in the status register) that is linearly related to the gas concentration measured. A 4 mA output indicates that no gas is detected. A 20 mA output indicates that the full-scale concentration is detected. The exact 4-20 mA is calculated using the following equation:

$$4\text{-}20 \text{ mA output} = 4 + 16 \times \text{gas reading} \div \text{full-scale reading.}$$

If the measured concentration is above the full-scale, the output is 21 mA (210 in the status register).

4. The “Gas Reading - %LEL x meter” register (no. 30,004/30,018) indicates the measured gas concentration in %LEL x meter units. For example, a value of 57 in this register would mean that the gas concentration is 0.57 LEL x meter.
5. For “Detailed Status”, the first byte is a general status indication that contains an ASCII character that represents the second (middle) letter in the status indicator codes (e.g., N = normal) as identified in the SafEye Instruction Manual. When the character is an ‘M’ (maintenance call), the second byte represents the cause of the maintenance call. This byte represents the first character in the status indicator code from the SafEye Instruction manual. Otherwise, the second byte is a space character.
6. The internal temperature of the detector (register 30,022) is represented as a signed byte (in the range -128 to +127), in °C.
7. The supply voltage (in Volts) is computed from register 30,023 using the following expression:
 
$$\text{Supply Voltage} = (\text{Register 30,023 value}) \times 0.1 \text{ Volt.}$$
8. The “Total Operating Hours” register (no. 30,024-30,025) holds the total net detector operating time (in hours) since it was produced. The time is represented as a long unsigned integer (4 bytes), divided into two words:
  - Register 30,024 holds the most significant word
  - Register 30,025 holds the least significant word.
9. The “Relay Status” (register 30,026) holds the current state of the detector’s relays. Each relay is represented by a single bit:
  - A value of 1 in a bit means that the relay is closed
  - A value of 0 means that it’s open.
  - TABLE 6-4 lists detector relays and their corresponding bits:

**Table 6-4. Relay Status (Register 30,010) Bits**

<b>BIT #</b>	<b>RELAY</b>
0 (LSB)	Fault
1	Alarm
2	Accessory
3-15	–

## Chapter 7, Holding Registers

- Holding Registers are the read/write registers of the detector.

**Table 7-1. Holding Registers**

REGISTER	REGISTER ADDRESS (HEX)	SIZE (BYTES)	NAME	DESCRIPTION
40,001	0000	1	Detector Address	Modbus address in the range 1-247 (see Note 1)
40,002	0001	2	Setup	Setup configuration (see TABLE 7-4)
40,003	0002	1	Gain Control	Three possible states: 0 – Normal operation 1 – S/N test (for maintenance) (see note 1) 2 – Other (read only)
40,004	0003	1	Window Heater - Mode	See Note 2
40,005	0004	1	Window Heater - On Temperature	See Note 2
40,006 – 40,016	0005 – 000F	22	-	Reserved for future use
40,017	0010	2	Mode Selector (Align / Standby / Calibration)	See Notes 1 and 3
40,018 – 40,032	0011 – 001F	30	-	Reserved for future use
40,033 – 40,034	0020 – 0021	4	User Tag	A tag (variable) for general use

**NOTES:**

1. Registers 40,001 and 40,017 (“Detector Address” and “Mode Selector”) cannot be set using a broadcast (a request sent to address 0). Register 40,003 (“Gain Control”) can be set, using a broadcast only to a value of 0 (“Normal operation”).
2. Registers 40,004 and 40,005 control the detector’s window heater operation. The “Window Heater - Mode” register (no. 40,004) controls the heater’s operation mode according to TABLE 7-2.

**Table 7-2. Window Heater Mode (40,004) Register Possible Values**

VALUE	DESCRIPTION
0	Constantly OFF
1	Automatic
2	Constantly ON

In the Automatic mode, the heater is turned ON and OFF according to the ambient temperature estimated by using the measured internal temperature.

- If this estimated temperature drops below the “Window Heater - On Temperature” (register 40,005), the heater turns ON.
- If the temperature rises above the “Window Heater – On Temperature”, the heater turns OFF.

The temperature held in the “Window Heater – On Temperature” register is represented in centigrade units in the range: 0-35°C.

The heater always turns OFF if internal detector temperature exceeds a level that might harm its electronic components.

3. The “Mode Selector (Align / Standby / Calibration)” register (no. 40,017) enables changing between the three maintenance modes (Align, Standby and Calibration). Individually, these modes can be used for diagnostic purposes. Their combined function is the same as the ‘Zero Calibration’ procedure in the SafEye Instruction Manual.

During normal detector operation, setting the value:

- “AX” to this register (the ASCII character ‘A’ in the first byte and the ASCII character ‘X’ in the second byte) sets the detector to the Alignment mode
- “AS” during the Alignment mode sets the detector to the Standby mode
- “AG” during the Standby mode sets the detector to the Calibration mode
- “AX” during the Calibration mode sets the detector back to the Alignment mode.

For Zero Calibration (as similarly described for manual operation in the SafEye Instruction Manual):

- Once commanded to Alignment mode (by sending “AX”), the user should query “Detailed Status” until an “X” is indicated.
- Then, once commanded to Standby Mode (by sending “AS”), the user should query “Detailed Status” until an “S” is indicated.
- Then, once commanded to Calibration Mode (by sending an “AG”), the user should query “Detailed Status” until a “G” is indicated
- Then, the user should continue to query “Detailed Status” until an “N” is indicated (return to normal mode, calibration completed).

The detector automatically turns back to its normal mode of operation after about two minutes in Alignment mode (“AX”), 20 seconds in the Standby mode (“AS”), or up to one minute in the Calibration mode (“AG”).

Reading this register (no. 40,017) returns the commanded mode of operation according to TABLE 7-3:

**Table 7-3. Mode Selector (40,017) Register Possible Values**

<b>MODE</b>	<b>RETURNED VALUE</b>
Normal operation	“AN”
Alignment	“AX”
Standby	“AS”
Calibration	“AG”

## The Setup Register

The setup register (40,002) is interpreted according to TABLE 7-4:

**Table 7-4. Status (40,002) Register - Bit Description**

BIT #	NAME	OFF (0)	ON (1)	DEFAULT
0 (LSB)	Flash Rate	Read Only, fixed at 0.5 sec		0
1	Flash Rate	Read Only, fixed at 0.5 sec		0
2	Gas Type	See note 1		-
3	Gas Type	See note 1		-
4	Gas Type	See note 1		-
5	Full Scale	Sensitivity of detection (see note 2)		0
6	Background Zero Calibration	Enabled	Disabled	0
7		Reserved for future use		
8	Accessory Relay	Not available		0
9	Accessory Relay	Not available		0
10	Alarm Latching	Disabled	Enabled (See note 0)	0
11	4-20 mA Mode (See TABLE 6-1 - note 3)	Continuous	Discrete	0
12	Indication when beam is blocked during Alarm	"Low/No Signal" State	"Alarm" State	0
13		Reserved for future use		
14		Reserved for future use		
15 (MSB)		Reserved for future use		

### NOTES:

- Bits #2, #3, and #4 set the gas type to be detected according to TABLE 7-5:

**Table 7-5. Setup (40,002) Register - Gas Type Configuration**

GAS NO.	BIT #4	BIT #3	BIT #2	GAS TYPE
Gas 1	0	0	0	Methane
Gas 2	0	0	1	Natural Gas
Gas 3	0	1	0	LPG
Gas 1	0	1	1	Reserved
Gas 2	1	0	0	Reserved
Gas 3	1	0	1	Reserved
Gas 1	1	1	0	Reserved
Gas 2	1	1	1	Reserved

2. Bit #5 controls the full scale gas concentration according to TABLE 7-6:

**Table 7-6. Setup (40,002) Register - Full Scale Configuration**

BIT #5	SENSITIVITY
0	Normal
1	High

The actual value of the full scale in %LEL x meter is held in register 30,033 ("Full Scale").

3. When alarm is latched, the relay outputs indicate alarm. If the detector was in the discrete mode (see bit #11 of the setup register), the 4-20 mA output would also indicate alarm.

Latching reset occurs by:

- a momentary power disconnection or
- setting the detector to alignment mode (see explanation for holding register 40,017). Set register 40,017 twice [i.e., to standby mode ("AX" followed by "AS")]; otherwise, the detector stays in alignment mode ("AX") for up to two minutes.

## Chapter 8, Practical Examples

### Reading Detector Status

The following example shows the most frequent query: checking a detector's status (address 30,003) for alarm, warning, fault, or normal operation. It uses function code 04 (read input registers).

#### Query:

FIELD NAME		EXAMPLE (HEX)
Slave Address		11
Function		04
Starting Address	Hi (register 30,003)	00
Starting Address	Lo (register 30,003)	02
No. of Registers	Hi	00
No. of Registers	Lo	01
CRC	Lo	XX
CRC	Hi	XX

#### Response:

FIELD NAME		EXAMPLE (HEX)
Slave Address		11
Function		04
Byte Count		02
Data Hi (Register 30,003 – dummy byte)		00
Data Lo (Register 30,003 - Status)		28 (decimal 40 - Normal state)
CRC Lo		XX
CRC Hi		XX

## Setting Detector Setup

The following example sets the SafEye detector setup configuration (Register 40,002), using function code 6 (preset single register).

### Query:

FIELD NAME	EXAMPLE (HEX)
Slave Address	11
Function	06
Register Address Hi	00
Register Address Lo	01
Preset Data Hi (Register 40,002 – bits 8-15)	11
Preset Data Lo (Register 40,002 – bits 0-7)	04
CRC Lo	XX
CRC Hi	XX

### Response:

FIELD NAME	EXAMPLE (HEX)
Slave Address	11
Function	06
Register Address Hi	00
Register Address Lo	01
Preset Data Hi (Register 40,002 – bits 8-15)	11
Preset Data Lo (Register 40,002 – bits 0-7)	04
CRC Lo	XX
CRC Hi	XX

## Reading Detector Setup

This example shows how to read a detector's setup configuration (Register 40,002) using function code 3 (read holding register).

### Query:

FIELD NAME	EXAMPLE (HEX)
Slave Address	11
Function	03
Starting Address Hi	00
Starting Address Lo	01
No. of Registers Hi	00
No. of Registers Lo	01
CRC Lo	XX
CRC Hi	XX

### Response:

FIELD NAME	EXAMPLE (HEX)
Slave Address	11
Function	03
Byte Count	02
Data Hi (Register 40,002 - bits 8-15)	11
Data Lo (Register 40,002 - bits 0-7)	04
CRC Lo	XX
CRC Hi	XX

## Setting Detector Address and Setup

This example changes the Modbus address of the detector and its setup configuration, using function code 16 (preset multiple registers).

The address of the detector is changed from 17 (11 hex) to 18 (12 hex). The setup register is set to a typical configuration.

### Query:

FIELD NAME	EXAMPLE (HEX)
Slave Address	11
Function	10
Starting Address Hi	00
Starting Address Lo	00
No. of Registers Hi	00
No. of Registers Lo	02
Byte Count	04
Data Hi (Register 40,001 – dummy byte)	00
Data Lo (Register 40,001 – Detectors Address)	12
Data Hi (Register 40,002 – bits 8-15)	11
Data Lo (Register 40,002 – bits 0-7)	04
CRC Lo	XX
CRC Hi	XX

### Response:

FIELD NAME	EXAMPLE (HEX)
Slave Address (before the change)	11
Function	10
Starting Address Hi	00
Starting Address Lo	00
No. of Registers Hi	00
No. of Registers Lo	02
CRC Lo	XX
CRC Hi	XX