

The XTIRPA XLT provides workers with great versatility when looking for elevated tie-off platform solutions. The XLT meets both ANSI and CSA standards for anchorage connectors, and is designed with solid steel for utmost durability in tough environments.

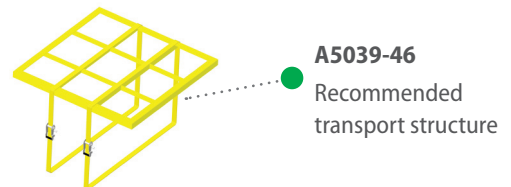
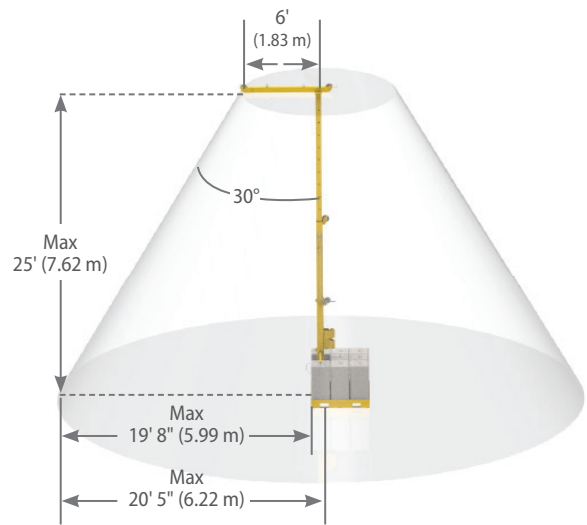
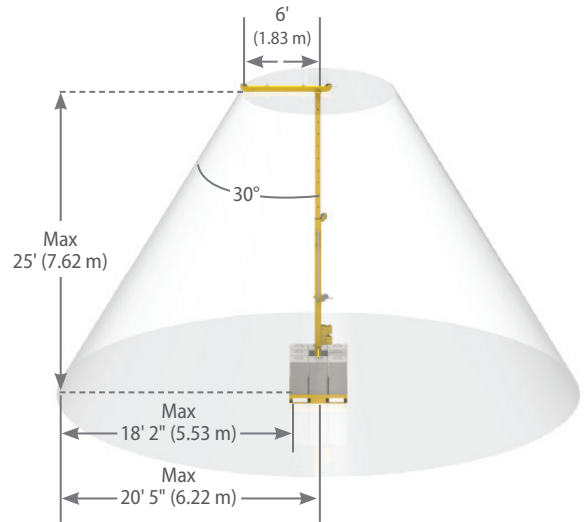
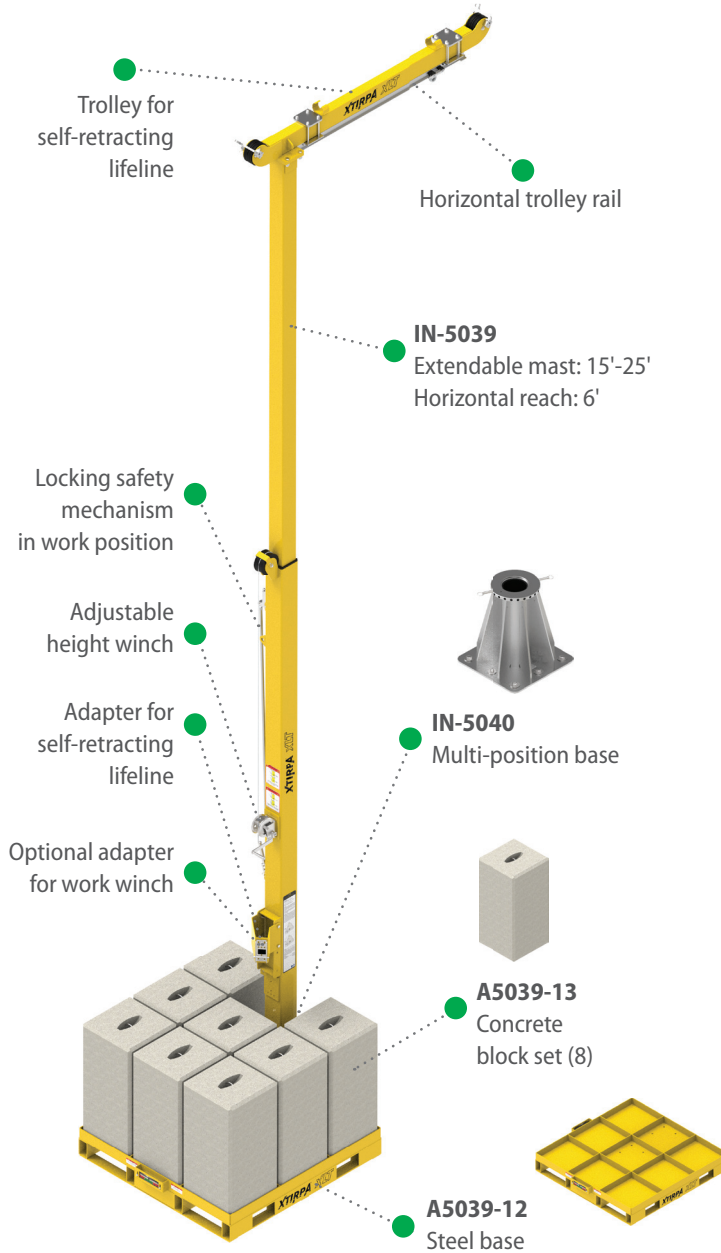

Meets ANSI Z359.18 and CSA Z259.15-17: Anchorage Connectors
Self-Retracting Lifelines sold separately